

Silverbeam™ 360 Rotating Searchlight

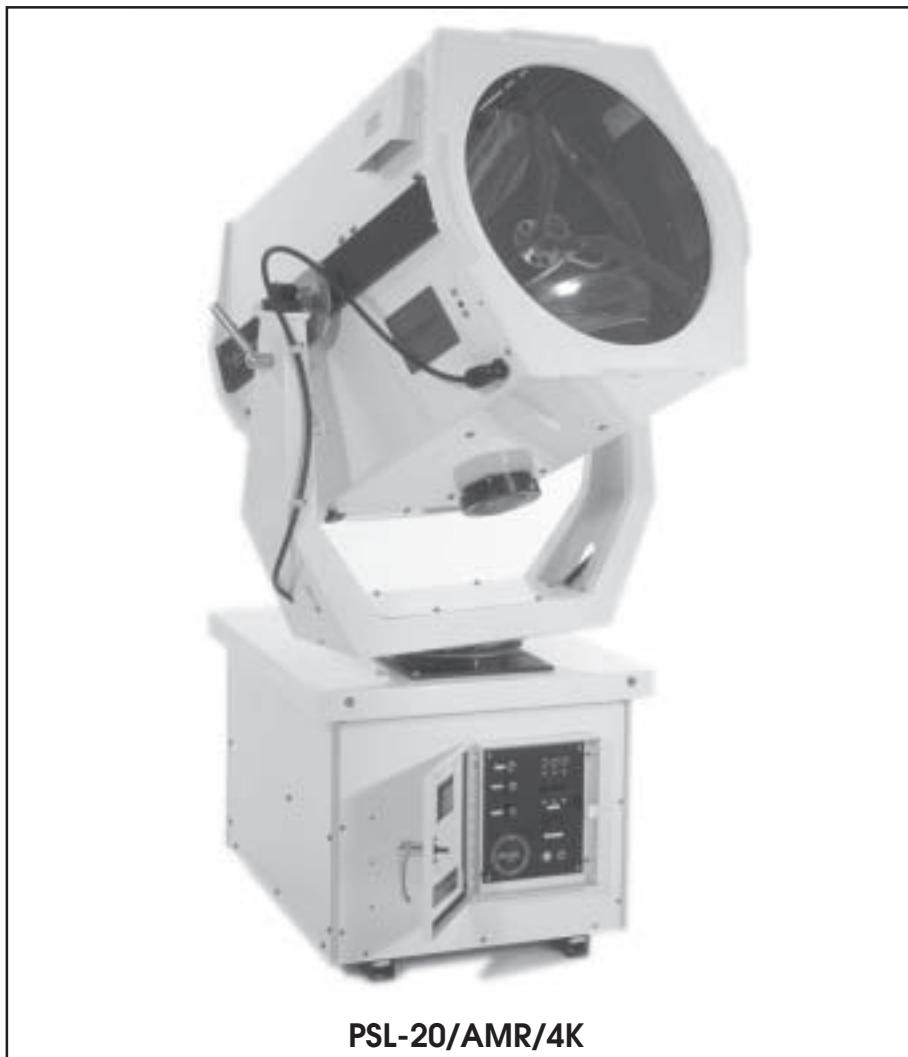

PSL-20/AMR/4K

DESCRIPTION

Introducing the Silverbeam 360 Rotating Searchlight. The latest addition to Phoebus Manufacturing's innovative line of lighting products. The newest member of our popular SILVERBEAM line of xenon searchlights is specifically designed for year round outdoor applications. The Silverbeam 360 is fully self-contained and weather tight, featuring auto-strike and a continuous 360° of motorized rotation.

Built with integrity, the Silverbeam 360 is designed for years of quiet, dependable, maintenance free service. Its chassis, housing, and cast bulkheads are constructed of rustproof aluminum and coated with a textured polyurethane finish designed to withstand the severest of outdoor conditions. Both 14" and 20" models utilize a corrosion resistant electroformed nickel-rhodium reflector. Manufactured with space age technology throughout, the Silverbeam 360 can be expected to operate with outstanding efficiency throughout the lifetime of the unit. With its 2000 hour lamp life, the 2KW xenon lamp delivers up to 55,000 foot candles of output. The 20" model 4KW and 7KW lamps rate a maximum of 70,000 and 105,000 foot candle output respectively over a 500-1000 hour lamp life. All lamps maintain a stable 6000K color temperature from 208, 220, 380, or 415 volt power.

Leading the way, Built with the quality craftsmanship you expect from a 25 year leader in special event lighting, the Phoebus Manufacturing Silverbeam 360 Rotating Searchlight offers reliability, affordability, and years of dependable service.

FEATURES

- Continuous 360° Motorized Rotation
- Polyurethane coated, lightweight aluminum Chassis, Housing and Bulkheads (Available in powder coat finishes)
- Nickel based rhodium plated electro-formed reflector
- 2KW, 4KW and 7KW xenon light source (lamp included)
- 6000K (Kelvin color temperature)
- Available in 208, 220, 380, and 415 volt magnetic ballasts. (Single & 3 phase operations)
- Auto-Strike ignition
- Variable Speed Control
- Reversible Rotation
- All systems are assembled with stainless steel external hardware
- ETL approved for wet locations

OPTIONS

- Configuration also available in a fixed model



Strong
Lighting

10533 Chandler Rd, Suite 101 La Vista,
NE 68128
Tel. 402-506-9096

www.strong.lighting

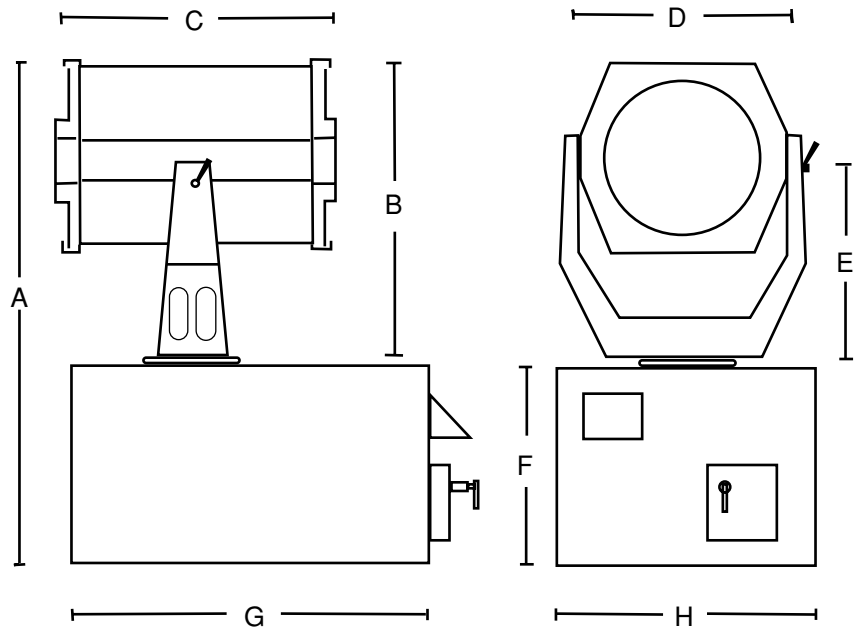

SPECIFICATIONS

		14" Model	20" Model
Overall Height	A	47.50"	50.50"
Height, Head w/Yoke	B	31.625"	53.00"
Head Length	C	24.50"	30.50"
Width, Head w/Yoke	D	24.00"	30.00"
Height, Pivot Point	E	22.375"	25.00"
Base Height	F	21.00"	21.00"
Base Length	G	29.50"	29.50"
Base Width	H	24.00"	24.00"
Horizontal Range(Motorized)		360° Continuous Sweep	360° Continuous Sweep
Vertical Tilt Range(Manual)		170° Sweep	170° Sweep
Lamp (Life Expectancy)		2KW Xenon (2000 Hours)	4KW or 7KW Xenon (1000/500 Hours)
System Weight		475lbs	550lbs
Magnetic Ballast		2KW-20AMP 220/240 Volt (Single Phase Operation)	4KW-25AMP 208, 380, or 415 Volt (Three Phase Operation) 7KW-35 AMP 208, 380, or 415 Volt (Three Phase Operation)
Rotation Speed		1 to 7 RPM — CW or CCW	1 to 7 RPM — CW or CCW

PRELIMINARY PHOTOMETRICS

Distance in Feet	Diameter	Beam Angle	Footcandles		
Position #1 Narrow Beam Setting			2K	4K	7K
50	14 & 20 inch	Collimated	55,000	70,000	105,000
100	14 & 20 inch	Collimated	13,750	17,500	26,250
200	14 & 20 inch	Collimated	3,400	4,500	6,750
Position #2 Medium Beam Setting					
50	14 & 20 inch	1.5°	36,000	54,000	81,000
100	24 inch	1.5°	9,000	13,500	20,250
200	36 inch	1.5°	2,260	3,400	5,100
Position #3 Wide Beam Setting					
50	5 feet	10°	3,500	11,250	16,875
100	10 feet	10°	875	2,813	4,220
200	25 feet	10°	220	700	1,050