

Xenotech, Inc.

BRITELIGHT® 2000 OPERATING MANUAL

1P HC REV 2.1
COPYRIGHT © 1997 Xenotech, Inc.

INSTRUCTIONS FOR INSTALLING GLOBE IN 16 INCH 2K FIXTURE

WARNING

A PROTECTIVE JACKET, FULL FACE SHIELD, AND GLOVES MUST BE WORN AT ALL TIMES WHEN THE LAMP HEAD IS OPENED OR WHEN HANDLING THE XENON GLOBES. SERIOUS INJURY MAY OCCUR IF PROPER SAFETY PRECAUTIONS ARE NOT OBSERVED. READ ALL ENCLOSED INSTRUCTIONS AND INFORMATION SHEETS BEFORE HANDLING THE GLOBE.

DISASSEMBLY PROCEDURE

1. REMOVE THE SCREWS THAT SECURE THE FRONT COWLING TO THE LAMP HEAD AND REMOVE THE COWLING.
2. REMOVE THE SCREWS THAT SECURE THE TOP COVER TO THE LAMP HEAD AND REMOVE THE COVER.
3. REMOVE THE NUT FROM THE TOP OF THE IGNITOR TRANSFORMER LOCATED ON THE REAR OF THE CENTER BULKHEAD NEXT TO THE LAMP COOLING PLENUM.
4. REMOVE THE SHORT LEAD FROM THE FRONT LAMP HOLDER.
5. REMOVE THE CENTER MOUNTING SCREW AND SPRING FROM THE SPIDER WHILE SUPPORTING THE FRONT LAMP HOLDER SO THAT IT DOES NOT FALL WHEN THE SCREW IS REMOVED.
6. REMOVE THE LAMP HOLDER FROM THE FIXTURE.
5. DISCONNECT THE FOCUS ROD SWIVEL JOINT FROM THE SPIDER ARM USING THE 5/16 AND 3/8 OPEN END WRENCHES. DO NOT TURN THE SWIVEL JOINT OR FOCUS ROD.

ASSEMBLY PROCEDURE

1. FASTEN THE REAR LEAD TO THE END OF THE LAMP THAT HAS THE SMALL ELECTRODE AND BE SURE THAT THE LEAD IS COVERED IN INSULATING TUBING.

NOTE

IT IS VERY IMPORTANT THAT THE POLARITY OF THE LAMP IS OBSERVED! THE LAMP WILL BE DESTROYED VERY QUICKLY IF IT IS RUN WITH THE POLARITY REVERSED! THE CORRECT ORIENTATION IS CATHODE (SMALL ELECTRODE) TOWARD THE REAR OF THE LAMP AND THE ANODE (LARGE ELECTRODE) TOWARD THE FRONT OF THE LAMP.

2. FASTEN FRONT LAMP HOLDER TO THE GLOBE BY REMOVING THE TWO SCREWS FROM THE CLAMP ON THE FRONT LAMP HOLDER AND REMOVING THE CLAMP. PLACE THE LAMP IN THE LAMP HOLDER ALIGNING THE STUD ON THE END OF THE LAMP FERRULE WITH THE CHANNEL IN THE FIXED SIDE OF THE LAMP HOLDER CLAMP. SLIDE THE LAMP DOWN UNTIL THE SHOULDER ON THE FERRULE CONTACTS THE CLAMP. RE-ATTACH THE CLAMP TO THE LAMP HOLDER.
3. INSTALL THE GLOBE INTO THE FIXTURE BY INSERTING THE LAMP LEAD THROUGH THE OPENING IN THE REFLECTOR, UP THROUGH THE PLENUM, AND THROUGH THE HOLE IN THE PLENUM UPPER ACCESS PANEL. INSERT THE STUD ON THE END OF THE LAMP FERRULE INTO THE OPENING IN THE REAR LAMP SUPPORT BRACKET WHILE PULLING THE LAMP LEAD THROUGH THE HOLE IN THE PLENUM UPPER ACCESS PANEL. SECURE THE FRONT LAMP HOLDER TO THE SPIDER. CONNECT THE SHORT LEAD FROM THE SPIDER TO THE FRONT LAMP HOLDER.
4. PLACE THE SHORT PIECE OF INSULATING TUBING OVER THE LEAD INSULATING TUBING SO THAT IT IS LOCATED AT THE APEX OF THE BEND WHEN THE LEAD IS ATTACHED TO THE IGNITOR TERMINAL.
5. ATTACH THE REAR LEAD LUG TO THE IGNITOR TERMINAL.
6. REMOVE THE PROTECTIVE COVER FROM THE GLOBE AND WIPE THE GLOBE COMPLETELY WITH ALCOHOL.
7. THE INSTALLATION IS NOW COMPLETE. REPLACE ALL PANELS AND COVERS AND TEST THE LAMP.

POWER INPUT CONNECTOR WIRING INSTRUCTIONS

THE INPUT POWER REQUIREMENTS FOR A 2 KW SOLID STATE POWER SUPPLY ARE AS FOLLOWS.

VOLTAGE NOMINAL 208/230 VAC

FREQUENCY RANGE 47 - 63 HZ

INPUT CURRENT 1 PHASE
 18.5 AMPS

MINIMUM INPUT WIRE SIZE 12 AWG

CONNECTIONS

SINGLE PHASE OPERATION

CONNECTOR TERMINAL	LINE DESIGNATION	PIN COLOR
W	N/C	WHITE N/C
X	PHASE A OR HOT	BLACK
Y	PHASE B OR NEUTRAL	RED
Z	N/C	BLUE N/C
GREEN	SAFETY GROUND	GREEN

ABRIDGED OPERATING INSTRUCTIONS FOR 2 KW XENON SYSTEM

NOTE

BEFORE OPERATING THE POWER SUPPLY IT MUST BE POSITIONED SO THAT THE REAR AIR EXHAUST VENTS ARE UNOBSTRUCTED.

CONNECTIONS

1. CONNECT LAMP HEAD TO THE LAMP HEAD CONNECTOR LOCATED ON THE FRONT PANEL
2. CONNECT THE POWER CORD TO THE AC INPUT POWER CONNECTOR.
3. WHEN THE POWER IS ENERGIZED THE INDICATOR LIGHTS NEXT TO THE INPUT POWER CONNECTOR WILL LIGHT INDICATING THE FOLLOWING CONDITIONS.

GROUND (GREEN LAMP): SAFETY GROUND AND THE HOT POWER INPUT LINE ARE CORRECTLY CONNECTED.

230 VAC IN (AMBER LAMP): 230 VOLT INPUT IS CONNECTED ACROSS THE HOT AND NEUTRAL LINES AND IS ENERGIZED.

AUX POWER (BLUE LAMP): AUXILIARY 120 VOLT POWER SUPPLY IS ENERGIZED.

4. WHEN THE CONNECTIONS ARE CORRECT THE BLOWER IN THE LAMP HEAD WILL OPERATE AND THE UNIT WILL BE READY TO LIGHT.

LIGHT OPERATION

1. PLACE THE MAIN POWER CIRCUIT BREAKER IN THE ON POSITION. THE INDICATOR LIGHTS NEXT TO THE OUTPUT POWER CONNECTOR WILL LIGHT INDICATING THE FOLLOWING CONDITIONS.

MAIN POWER (GREEN LAMP): LOW VOLTAGE HIGH CURRENT POWER SUPPLY IS ENERGIZED AND READY TO RUN THE LAMP.

BOOST READY (GREEN LAMP): HIGH VOLTAGE LOW CURRENT POWER SUPPLY IS ENERGIZED. THIS LAMP WILL LIGHT 10 - 15 SECONDS AFTER THE POWER SWITCH HAS BEEN TURNED ON INDICATING THAT THE OPEN CIRCUIT OUTPUT VOLTAGE IS OVER 100 VDC AND THE SUPPLY IS READY TO IGNITE THE LAMP. THE LAMP CAN BE IGNITED BEFORE THIS INDICATOR HAS LIT IF NECESSARY.

ONCE THE POWER SUPPLY IS ENERGIZED AND THE READY INDICATORS ARE LIT STEPS 2 - 4 MAY BE PREFORMED EITHER AT THE POWER SUPPLY OR THE REAR OF THE LAMP HEAD.

2. MOVE THE LAMP SWITCH TO THE STRIKE POSITION. WHEN THE LAMP LIGHTS RELEASE THE LAMP SWITCH. IF THE LAMP DOES NOT LIGHT IMMEDIATELY RELEASE THE SWITCH WAIT 5 SECONDS OR UNTIL THE BOOST READY LAMP LIGHTS AND RE-TRY.
3. FOCUS THE LIGHT FOR THE DESIRED EFFECT BY MOVING THE FOCUS SWITCH TO THE FORWARD OR REVERSE POSITION AND HOLD THE SWITCH. THE FOCUS MECHANISM WORKS ON A CAM ACTION AND WILL CYCLE FROM FULL FLOOD TO FULL SPOT UNTIL THE FOCUS SWITCHED IS RELEASED. MOVING THE SWITCH TO THE OPPOSITE POSITION WILL REVERSE THE FOCUS ACTION.

4. TO TURN OFF THE LIGHT MOVE THE LAMP SWITCH TO THE OFF POSITION. IF THE LIGHT IS NOT GOING TO BE IMMEDIATELY REUSED DE-ENERGIZE THE POWER SUPPLY.
5. TO DE-ENERGIZE THE POWER SUPPLY PLACE THE POWER CIRCUIT BREAKER IN THE OFF POSITION.

CAUTION

ALLOW THE GLOBE TO COOL COMPLETELY BEFORE DISCONNECTING THE INPUT POWER. CONNECTOR. THE COOLING SYSTEM IN THE HEAD WILL RUN WHEN EVER THE INPUT LINES ARE ENERGIZED.

NOTE

THE LAMP HEAD AND POWER SUPPLY ARE THERMALLY PROTECTED. IF THE COOLING SYSTEM FAILS OR THE EQUIPMENT IS USED IN AN EXCESSIVELY HOT ENVIRONMENT THE LAMP WILL SHUT OFF TO PREVENT DAMAGE. IF THE HEAD OVERHEATS THE HEAD OVER TEMP INDICATOR ON THE FRONT PANEL WILL LIGHT AND WILL REMAIN LIT UNTIL THE LAMP HEAD COOLS TO A SAFE OPERATING TEMPERATURE. IF THE POWER SUPPLY OVERHEATS THE MAIN READY INDICATOR WILL GO OUT AND WILL REMAIN UNLIT UNTIL THE POWER SUPPLY COOLS TO A SAFE OPERATING TEMPERATURE. WHEN THE INDICATORS RETURN TO A NORMAL STATE THE LAMP MAY BE RE-STRUCK.

CAUTION

THE POWER SUPPLY CONTAINS A CAPACITOR BANK ACROSS THE OUTPUT TERMINALS THE ENERGY STORED IN THE CAPACITORS MAY BE PRESENT FOR SEVERAL MINUTES AFTER THE POWER SUPPLY IS DE-ENERGIZED.

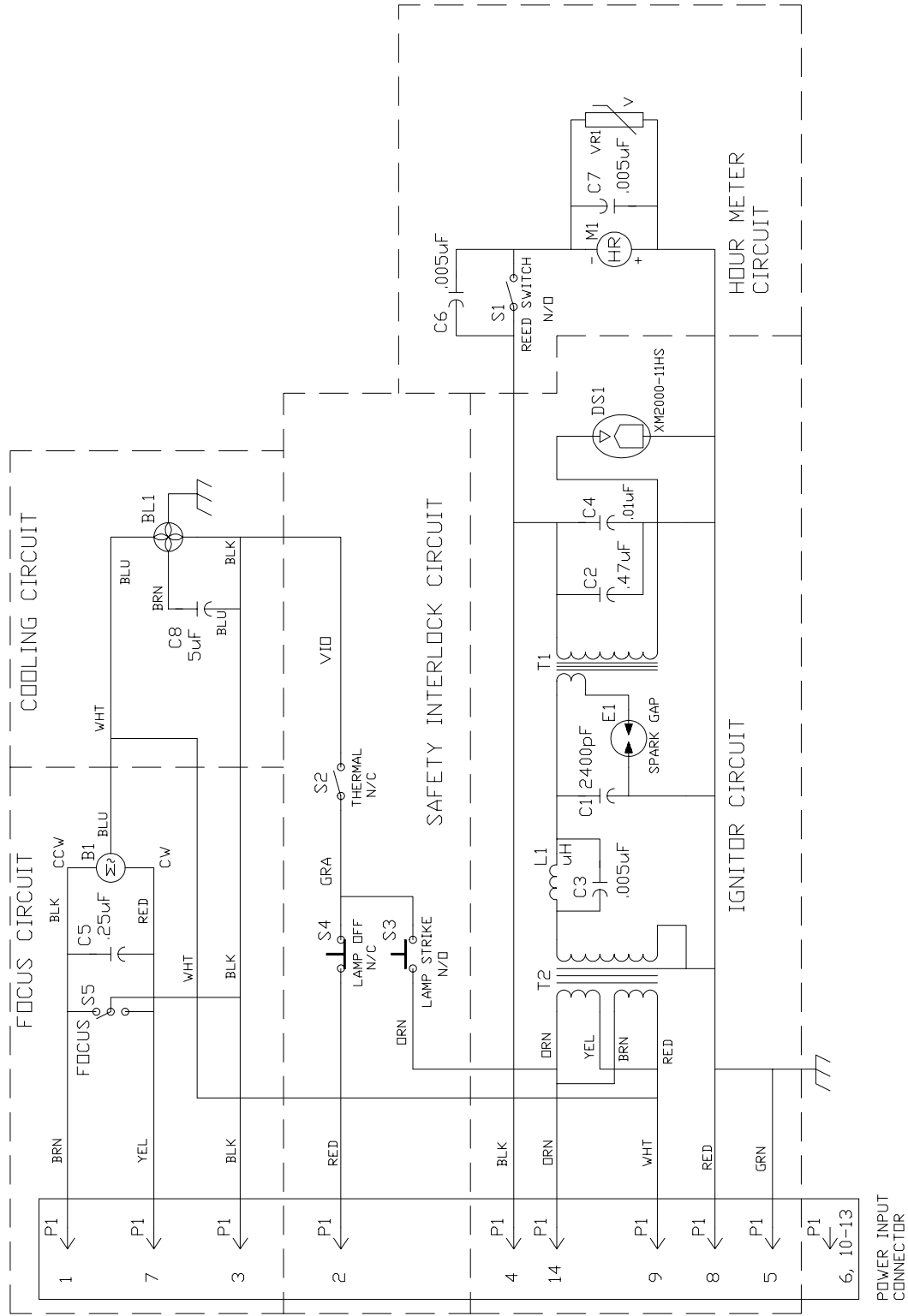

2KW LAMPHEAD SCHEMATIC

INSTALLATION AND CALIBRATION FOR 2KW POWER MODULE

CAUTION

INSPECT SYSTEM WIRING FOR ANY CONDITION THAT MAY HAVE CAUSED MODULE FAILURE AND CORRECT CONDITION BEFORE INSTALLING NEW MODULE.

MODULE REMOVAL

1. REMOVE TOP COVER FROM THE POWER SUPPLY BY ROTATING THE INTERNAL COVER LATCHES LOCATED ON THE REAR AND SIDES OF THE POWER SUPPLY. (USE THE WRENCH SUPPLIED WITH THE UNIT)
2. REMOVE THE 8 SCREWS RETAINING THE FRONT PANEL.
3. REMOVE THE CHASSIS RETAINING HARDWARE.
4. LIFT THE CHASSIS AND FRONT PANEL FROM THE CASE.
5. REMOVE THE WIRING FROM THE DEFECTIVE MODULE WHILE NOTING THE CONNECTIONS FOR REASSEMBLY.
6. REMOVE THE 4 RETAINING SCREWS FROM THE BOTTOM OF THE CHASSIS UNDER THE DEFECTIVE MODULE AND SLIDE THE MODULE FORWARD AND LIFT FROM THE CHASSIS.

MODULE INSTALLATION

1. REVERSE MODULE REMOVAL PROCEDURE STEPS 6 - 3 DO NOT ATTACH THE FRONT PANEL UNTIL THE CALIBRATION IS COMPLETE.

CALIBRATION FOR 2KW POWER MODULE

POWER SUPPLY CALIBRATION

CAUTION

THE POWER SUPPLY CALIBRATION PROCEDURE REQUIRES THE UNIT TO BE ENERGIZED WHILE BEING CALIBRATED. USE EXTREME CAUTION DURING THE CALIBRATION NOT TO COME IN CONTACT WITH THE LIVE CONNECTIONS ON THE FRONT PANEL AND CHASSIS. VOLTAGES FROM 240 VAC TO 160 VDC MAY BE PRESENT ON THE INPUT AND OUTPUT WIRING WHENEVER THE UNIT MAIN INPUT POWER LINES ARE ENERGIZED.

WARNING

POTENTIAL SHORT CIRCUIT CONDITION

DO NOT ALLOW THE TERMINALS OF THE MAIN CIRCUIT BREAKER TO COME IN CONTACT WITH THE FRONT PANEL MOUNTING RAILS IF THE FRONT PANEL IS REMOVED.

EQUIPMENT REQUIRED

DC VOLT METER 0 - 200 VDC
DC CLAMP ON AMMETER 0 - 200 ADC

CALIBRATION

1. ATTACH THE LAMP HEAD TO THE POWER SUPPLY OUTPUT CONNECTOR USING A 50 FT HEAD EXTENSION AND POINT THE LAMP STRAIGHT UP.
2. ATTACH THE POWER FEEDER TO THE POWER INPUT CONNECTOR.
3. CONNECT THE AMMETER AROUND THE LARGE RED CABLE RUNNING FROM THE HEATSINK TO THE OUTPUT CONNECTOR.
4. CONNECT THE POWER FEEDER TO THE POWER LINE AND SET THE MAIN BREAKER TO THE ON POSITION.
5. MEASURE THE VOLTAGE ACROSS THE OUTPUT TERMINALS OF THE POWER MODULE AND ADJUST THE VOLTAGE TO 30 VDC USING THE VOLTAGE ADJUSTMENT LOCATED AT THE RIGHT CENTER OF THE FRONT OF THE MODULE.
6. REMOVE THE VOLTMETER FROM THE CIRCUIT AND STRIKE THE LIGHT.
7. READ THE OUTPUT CURRENT ON THE AMMETER. IF THE CURRENT IS OVER 85 AMPS AFTER 30 SECONDS; TURN OFF THE LIGHT. REDUCE THE OUTPUT CURRENT TO LESS THAN 85 AMPS USING THE MODULE CURRENT ADJUSTMENT AS FOLLOWS. IF THE CURRENT IS LESS THAN 85 AMPS GO TO STEP 9.

NOTE

THE CURRENT ADJUSTMENT IS LOCATED ON THE LEFT CENTER FRONT OF THE MODULE AS YOU ARE FACING THE FRONT OF THE UNIT. THE ADJUSTMENT IS UNMARKED. THE ADJUSTMENT IS A 10 TURN POTENTIOMETER. TURNING THE ADJUSTMENT COUNTERCLOCKWISE DECREASES THE OUTPUT CURRENT.

8. RESTRIKE THE LIGHT AND REPEAT STEP 7 UNTIL THE CURRENT IS LESS THAN 85 AMPS.
9. ONCE THE START CURRENT IS SET ALLOW THE LAMP TO BURN FOR AT LEAST 5 MINUTES OR UNTIL THE CURRENT READING STABILIZES.
10. AFTER THE SYSTEM HAS STABILIZED CONNECT THE VOLTMETER POSITIVE LEAD TO THE HEATSINK AND THE NEGATIVE LEAD TO THE NEGATIVE TERMINAL OF THE MODULE.
11. CALCULATE THE TOTAL SYSTEM OUTPUT POWER USING THE FORMULA $E \times I = W$. WHERE E = OUTPUT VOLTAGE, I = OUTPUT CURRENT, W = OUTPUT POWER IN WATTS. THE SYSTEM SHOULD BE SET TO RUN BETWEEN 1951 - 1999 WATTS.

CAUTION

THE INDIVIDUAL POWER OUTPUT OF A SINGLE MODULE MUST NOT EXCEED 2000 WATTS. EXCEEDING THE MAXIMUM POWER LIMIT MAY DAMAGE THE MODULE.

12. THE SYSTEM CALIBRATION IS NOW COMPLETE. TURN THE LAMP OFF AND ALLOW THE GLOBE TO COOL AT LEAST 5 MINUTES. DISCONNECT THE MAIN INPUT POWER LINE AND REPLACE THE FRONT PANEL AND TOP COVER.