

BRITELIGHT

SUPER 10

ARCHITECTURAL SEARCHLIGHT

Equipment Type 32-00111

Operator's Manual & Parts List

Issue July 2004



XENON BULB SAFETY PROCEDURES

THE XENON BULB is highly pressurized. When ignited, the normal operating temperature of the bulb increases the pressure to a level at which the bulb may explode if not handled in strict accordance to the manufacturer's operating instructions. The bulb is stable at room temperature, but may still explode if dropped or otherwise mishandled.

REFER ALL BULB REPLACEMENT and service to QUALIFIED PERSONNEL with adequate protective clothing (face shield, clean cotton gloves, welder's jacket). For routine lamphouse service, observe the following rules:

1. Allow the bulb to cool to room temperature before opening the lamphouse. Put on protective clothing described above.
2. De-energize the xenon power supply at the AC source before opening the lamphouse compartment.
3. When possible, encase the bulb in its protective cover when cleaning or servicing the lamphouse interior. The bulb, when outside the lamphouse, must be encased in the cover.
4. Clean the bulb after it has cooled to room temperature. Do not touch the quartz envelope of the bulb; fingerprints will burn in and create hot spots which may shorten bulb life. If fingermarks are made, they should be carefully removed with methyl alcohol and cotton prior to bulb operation.
5. Never view an ignited bulb directly. **BLINDNESS OR PERMANENT EYE DAMAGE MAY BE INCURRED.**
6. Use only xenon bulbs designated as OZONE FREE.
7. Maintain the lamphouse blower in good operating condition. Keep the blower inlet clean for unrestricted air flow.
8. To insure maximum bulb life, operate the lamphouse blower for *at least* ten minutes after extinguishing the bulb.
9. If returning a bulb for warranty adjustment, pack it in its original shipping container. Complete and return all required warranty information.
10. Dispose of expired bulbs that are beyond warranty in the following manner: Wrap the bulb tightly in several layers of canvas or heavy cloth. Place it on a hard surface and shatter the envelope with a sharp hammer blow. **DO NOT** place an unshattered bulb in an ordinary refuse container.
11. **DO NOT PERMIT UNAUTHORIZED PERSONNEL TO PERFORM OR ATTEMPT ANY PHASE OF XENON BULB HANDLING OR SERVICE.**

PREFACE

The **Britelight SUPER 10** is a 10,000 watt xenon searchlight mounted on a weather-proof base and power supply enclosure. The angle of light projection is adjustable through a 90° arc, and can be locked manually in the desired position. The unit may be permanently installed at a venue, mounted on heavy-duty casters, and/or paired with a trailer and diesel engine-generator unit.

Continuous high output performance is assured by means of a coated, 30 inch precision electroformed, parabolic nickel reflector. The reflector is carefully positioned at the factory and requires no operator adjustment. The light source is a 10,000 watt xenon bulb which can operate in any position (vertical to horizontal) and maintains a constant color temperature of 5600° Kelvin. A squirrelcage blower is mounted in the lamphead to provide continuous forced-air cooling while the bulb is in operation. A thermal switch in the lamphead will interrupt operation of the bulb to prevent heat damage if temperatures inside the lamphead exceed 325° Fahrenheit (163° C).

Operator controls mounted to the power supply enclosure include LAMP ON/OFF switches and a FOCUS switch. An AC motor inside the lamphead moves the bulb inside the reflector to adjust focus. An hour meter, located adjacent to the switches, records the elapsed time of xenon bulb operation.

Direct current for the xenon bulb is derived from two high reactance xenon power supplies mounted in the base of the unit. All models are designed for 50/60 Hertz operation, and are available in varying AC input types, depending upon the configuration of the main power transformer. Check the Equipment Data Plate to determine the exact AC requirement prior to installation.

Coarse and fine taps are easily set to regulate the DC current to the xenon lamphead. Some models of these power supplies have the capability of overdriving the xenon bulb; carefully check the power requirements specified by the bulb manufacturer and do not exceed the maximum current stated.

The two power supply chassis, wired in parallel, produce the high open circuit ("no load") voltage required for bulb ignition, and, after ignition, the filtered low voltage current to sustain operation. The bridge rectifiers utilize silicon diodes as the power conversion elements. The diodes are mounted to oversize heat sinks to disperse the heat generated by normal operation. Internally wired squirrelcage blowers provide additional forced-air cooling of each power supply. Thermal switches act as safety interlocks to shut down the power supplies and protect the rectifier diodes in case temperatures reach excessive levels.

INSTRUCTIONS FOR REMOVING AND INSTALLING A TYPE "XT" XENON BULB IN A SUPER 10 FIXTURE

NOTE

FAMILIARIZE YOURSELF WITH THE LOCATION AND IDENTIFICATION OF THE COMPONENTS OF THIS SYSTEM AND ALSO THE NORMAL OPERATION OF THE SYSTEM BEFORE ATTEMPTING ANY ADJUSTMENT OR SERVICE.

NOTE

COMPLETELY READ THROUGH AND HAVE A GOOD UNDERSTANDING OF THE PROCEDURES BEFORE ATTEMPTING TO SERVICE THIS SYSTEM. FAILURE TO DO SO MAY RESULT IN FATAL INJURY OR EQUIPMENT DAMAGE.

NOTE

THE LAMPHEAD SHOULD BE LOCKED IN THE HORIZONTAL POSITION DURING THE LAMPING PROCEDURES.

WARNING

DISCONNECT POWER SOURCE BEFORE SERVICING THIS EQUIPMENT.

WARNING

A PROTECTIVE JACKET, FULL FACE SHIELD, AND PROTECTIVE GLOVES MUST BE WORN AT ALL TIMES WHEN THE LAMPHEAD IS OPENED WITH A BULB INSTALLED OR WHEN HANDLING THE XENON LAMPS. SERIOUS INJURY MAY OCCUR IF PROPER SAFETY PRECAUTIONS ARE NOT OBSERVED. READ ALL ENCLOSED INSTRUCTIONS AND INFORMATION SHEETS BEFORE HANDLING THE LAMP.

WARNING

NEVER OPERATE A FIXTURE WITH AN EXPOSED BULB! THERE IS AN EXTREME DANGER OF SEVERE BURNS TO EXPOSED SKIN AND EYES FROM THE ULTRAVIOLET LIGHT EMITTED FROM THE EXPOSED LAMP. DAMAGE CAN OCCUR IN AS LITTLE AS 30 SECONDS OF EXPOSURE. THERE IS ALSO AN ADDITIONAL DANGER FROM FLYING QUARTZ IF AN EXPOSED LAMP EXPLODES!

EQUIPMENT REQUIRED

- 1. PROTECTIVE SAFETY EQUIPMENT KIT**
- 2. 7/16" WRENCH OR SOCKET**
- 3. ALLEN WRENCH 5/32"**

DISASSEMBLYPROCEDURE

PRIORTO BULB INSTALLATION:

1. RELEASE THE (4) FASTENERS LOCATED AT THE SMALL SIDES OF THE COWL BY PRESSING IN ON THE FASTENERS AND PULLING FORWARD TO REMOVE THE COWLING.
2. REMOVE THE (2) BRASS BOLTS CONNECTING THE SHORT LEADS TO THE FRONT LAMP HOLDER USING A 7/16" WRENCH.
3. REMOVE THE CENTER MOUNTING SCREW WASHER AND SPRING FROM THE SPIDER USING A 5/32" ALLEN WRENCH WHILE SUPPORTING THE FRONT LAMP HOLDER SO THAT IT DOES NOT FALL WHEN THE SCREW IS REMOVED.
4. REMOVE THE LAMP HOLDER FROM THE FIXTURE.
5. TO DISASSEMBLE THE FRONT LAMP HOLDER, REMOVE THE (2) CLAMP RETAINING SCREWS LOCATED ON THE SIDE OF THE LAMP SWIVEL HUB USING A 5/32" ALLEN WRENCH AND REMOVE THE CLAMP.

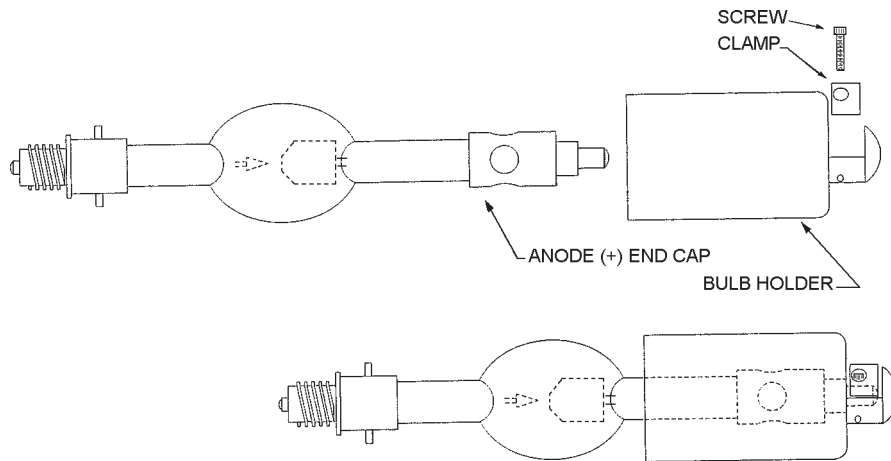

ASSEMBLY PROCEDURE

WARNING

DO NOT REMOVE THE PROTECTIVE COVER FROM THE BULB UNTIL INSTRUCTED TO DO SO!

WARNING

DO EXERT ANY FORCE ON THE QUARTZ PORTIONS OF THE BULB AT ANY TIME!

NOTE

IF THE FRONT LAMP HOLDER HAS NOT BEEN DISASSEMBLED, SEE THE LAST STEPS IN THE APPROPRIATE DISASSEMBLY INSTRUCTIONS.

1. UNTIE THE CORD ON THE ANODE END OF THE PROTECTIVE COVER. DO NOT REMOVE THE COVER AT THIS TIME!
2. FASTEN FRONT BULB HOLDER TO THE BULB BY PLACING THE ANODE END (LARGE ELECTRODE) OF THE BULB IN THE BULB HOLDER AND ALIGNING THE STUD ON THE END OF THE BULB FERRULE WITH THE CHANNEL IN THE NOSE OF THE BULB HOLDER BODY. SLIDE THE BULB COMPLETELY DOWN THE CHANNEL AS FAR AS IT WILL GO.

DISASSEMBLY PROCEDURE (continued)

WARNING

DO NOT APPLY ANY PRESSURE ON THE BULB WHILE REASSEMBLING THE FRONT BULB HOLDER!

3. REPLACE THE CLAMP AND REINSTALL THE (2) CLAMP RETAINING SCREWS LOCATED ON THE SIDE OF THE BULB SWIVEL HUB USING A 5/32" ALLEN WRENCH.
5. INSTALL THE BULB INTO THE FIXTURE BY INSERTING THE CATHODE END OF THE BULB THROUGH THE OPENING IN THE REFLECTOR.
6. INSERT THE END OF THE BULB FERRULE INTO THE OPENING IN THE BULB LAMP HOLDER RECEIVER BLOCK AND ALIGN THE THREADS BY TURNING THE BULB COUNTERCLOCKWISE UNTIL THE BULB THREADS DROP INTO THE RECEIVER THREADS.

CAUTION

DO NOT OVERTIGHTEN THE LAMP IN THE RECEIVER BLOCK AS THIS MAY CAUSE THE LAMP TO "FREEZE" IN THE RECEIVER BLOCK, MAKING IT DIFFICULT TO REMOVE. TIGHTEN THE LAMP JUST ENOUGH TO APPLY SPRING PRESSURE TO THE THREADS BUT NOT SO MUCH AS TO BOTTOM OUT THE LAMP FERRULE COMPLETELY AGAINST THE RECEIVER BLOCK.

7. GENTLY ROTATE THE BULB CLOCKWISE UNTIL RESISTANCE IS FELT.
8. AT THIS POINT, THE BULB SHOULD BE IN CONTACT WITH THE SPRING PLUNGER ASSEMBLIES. GENTLY TURN THE BULB AN ADDITIONAL 1/16 - 1/8 OF A TURN TO LOAD THE THREADS WITH THE SPRING PLUNGERS.
9. SECURE THE FRONT BULB HOLDER TO THE SPIDER WITH THE SHOULDER BOLT, SPRING, AND WASHER THAT WAS REMOVED DURING DISASSEMBLY.
10. CONNECT THE (2) SHORT LEADS FROM THE SPIDER TO THE FRONT BULB HOLDER USING THE (2) BRASS BOLTS AND WASHERS THAT WERE REMOVED DURING DISASSEMBLY.

NOTE

ANY TYPE OF ALCOHOL IS SUITABLE FOR CLEANING THE BULB EXCEPT FOR ALCOHOL THAT HAS BEEN DENATURED USING PETROLEUM PRODUCTS SINCE THE DENATURING AGENT WILL LEAVE A RESIDUE ON THE QUARTZ ENVELOPE.

11. REMOVE THE PROTECTIVE COVER FROM THE BULB AND CLEAN THE QUARTZ PORTION OF THE BULB COMPLETELY WITH ALCOHOL.
12. THE INSTALLATION IS NOW COMPLETE. REPLACE THE FRONT COWL AND TEST THE BULB.
13. LOG THE HOUR METER READING AT INSTALLATION.
14. PERFORM THE POWER SUPPLY OUTPUT ADJUSTMENT PROCEDURES.
15. PERFORM THE FOCUS AND X-Y PROCEDURES.

DISASSEMBLY PROCEDURE (continued)

IF THERE IS A BULB IS INSTALLED IN THE FIXTURE:

1. RELEASE THE (4) FASTENERS LOCATED AT THE SMALL SIDES OF THE COWL BY PRESSING IN ON THE FASTENERS AND PULLING FORWARD TO REMOVE THE COWLING.

CAUTION

DO NOT PLACE ANY EXCESSIVE FORCE ON THE BULB WHILE REPLACING THE PROTECTIVE WRAPPER!

2. WRAP THE BULB SECURELY IN THE PROTECTIVE WRAPPER THAT THE BULB WAS ORIGINALLY SHIPPED WITH.
3. REMOVE THE (2) BRASS BOLTS CONNECTING THE SHORT LEADS TO THE FRONT BULB HOLDER USING A 7/16" WRENCH.
4. REMOVE THE CENTER MOUNTING SCREW WASHER AND SPRING FROM THE SPIDER USING A 5/32" ALLEN WRENCH WHILE SUPPORTING THE FRONT BULB HOLDER SO THAT THE BULB DOES NOT DROP WHEN THE MOUNTING SCREW IS REMOVED.

WARNING

DO NOT EXERT EXCESSIVE FORCE ON THE BULB WHILE UNSCREWING IT FROM THE REAR LAMP HOLDER! THE BULB SHOULD RELEASE FROM THE REAR LAMP HOLDER WITH A VERY LIGHT COUNTER CLOCKWISE ROTATION. IF THIS DOES NOT HAPPEN, SEE THE PROCEDURE FOR REMOVING A "FROZEN" BULB.

5. REMOVE THE BULB BY LIGHTLY PUSHING BACK ON THE BULB TO MOVE THE REAR BULB HOLDER TO ITS REAR MOST POSITION WHILE LIGHTLY TURNING THE BULB IN A COUNTERCLOCKWISE ROTATION. THE BULB WILL RELEASE FROM THE REAR BULB HOLDER IN APPROXIMATELY 1½ COMPLETE TURNS.
6. REMOVE THE BULB WITH THE FRONT BULB HOLDER ATTACHED FROM THE FIXTURE. PLACE IT ON A STABLE WORKING SURFACE FOR THE REMOVAL OF THE FRONT BULB HOLDER.
7. TO REMOVE THE FRONT BULB HOLDER FROM THE BULB, REMOVE THE (2) CLAMP RETAINING SCREWS LOCATED ON THE SIDE OF THE BULB SWIVEL HUB USING A 5/32" ALLEN WRENCH AND REMOVE THE CLAMP.
8. REMOVE THE BULB HOLDER FROM THE BULB AND PLACE THE BULB INTO ITS SHIPPING CONTAINER FOR SAFE KEEPING. RESECURE THE PROTECTIVE WRAPPER IF NECESSARY.

REMOVING A "FROZEN" BULB

1. REPLACE THE FRONT BULB HOLDER RETAINING BOLT TO SUPPORT THE FRONT OF THE BULB WHILE FREEING THE BULB FROM THE REAR BULB HOLDER.

WARNING

DO EXERT ANY FORCE ON THE QUARTZ PORTIONS OF THE BULB WHILE ATTEMPTING TO FREE IT FROM THE REAR LAMP HOLDER!

2. REACH THROUGH THE OPENING IN THE REAR OF THE REFLECTOR AND GRASP THE BULB BY ITS REAR FERRULE, AND WHILE LIGHTLY PUSHING THE BULB BACK INTO THE RECEIVER BLOCK, TURN THE BULB IN A COUNTERCLOCKWISE DIRECTION UNTIL THE BULB BEGINS TO ROTATE FREELY.

REMOVING A "FROZEN" BULB (continued)

- ONCE THE BULB IS FREE, DO NOT REMOVE IT COMPLETELY FROM THE REAR LAMP HOLDER.
- RETURN TO STEP 5 OF THE PRECEDING SECTION.

OUTPUT POWER ADJUSTMENT PROCEDURES

NOTE

FAMILIARIZE YOURSELF WITH THE LOCATION AND IDENTIFICATION OF THE COMPONENTS OF THIS SYSTEM AND ALSO THE NORMAL OPERATION OF THE SYSTEM BEFORE ATTEMPTING ANY ADJUSTMENT OR SERVICE.

NOTE

COMPLETELY READ THROUGH AND HAVE A GOOD UNDERSTANDING OF THE PROCEDURES BEFORE ATTEMPTING TO SERVICE THIS SYSTEM. FAILURE TO DO SO MAY RESULT IN FATAL INJURY OR EQUIPMENT DAMAGE.

WARNING

DISCONNECT POWER SOURCE BEFORE SERVICING THIS EQUIPMENT.

EQUIPMENT REQUIRED

- SCREWDRIVER, FLAT BLADE, LARGE
- SCREWDRIVER, #2 PHILLIPS

ADJUSTMENT INSTRUCTIONS

- Remove lower access covers from the ends of the base enclosure by removing the 6 screws along the sides of each panel with a 3/8 wrench.
- Note the location and settings of the power supply adjustment taps.

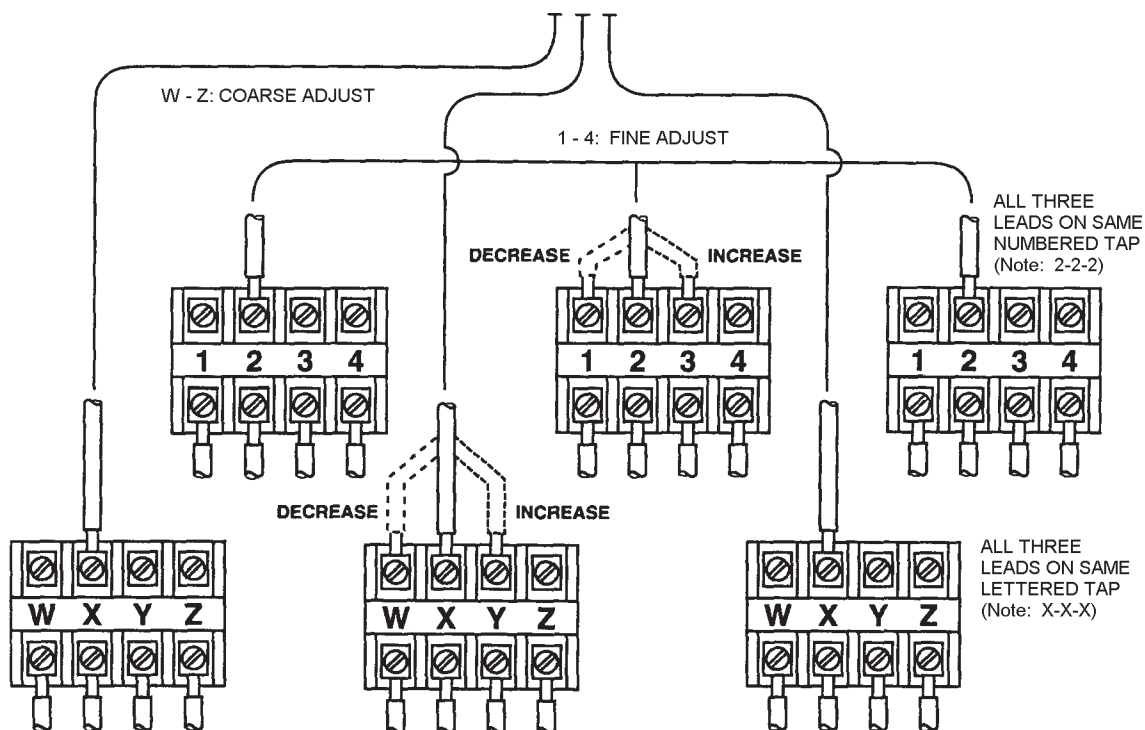

OUTPUT POWER ADJUSTMENT PROCEDURES (continued)

3. Set the main power switch to the ON position. The unit cooling system should start immediately, and the lamp should strike after a several second delay. If nothing happens, and the selector switch is set per step 3, check the main three phase power supplying this system. In all likelihood, the main power has been turned off at the source. If the system has power, the output setting may be too low to activate the auto strike circuit. Momentarily press the MANUAL strike switch to ignite the lamp.
4. Measure the output voltage and current using the meters on the control panel. The current range for a 10 kW xenon bulb is 180-210 A.DC. The DC voltage will vary between individual bulbs, but should fall between 45-55 V.DC.
5. A new xenon bulb is initially operated at around 85% of its maximum current (190 A.). As the bulb ages, the light output will decrease as the quartz envelope darkens in the course of normal aging. When this occurs, the output current may be adjusted upward, thus increasing the light. DO NOT, at any time, set the output in excess of the maximum rated current (210 A.).
6. Allow a few minutes for the current to stabilize, and note the operating current as displayed on the ammeter. If the current is in excess of 190 amperes, shut off the lamp and proceed to Step 9.
7. Turn off the light using the main power switch on the control panel. The cooling system will continue to run for at least 30 minutes after the power is turned off. Do not be concerned. The power to the power supply adjustment taps have been disconnected by the unit's main power contactor.

WARNING

**All three terminal blocks in the coarse and fine adjustment groups must be set at the same letter (W-W-W) or number (1-1-1) tap setting on both power supplies. Failure to observe the correct tap settings will result in shortened bulb life, excessive input current draw, and possible equipment damage.
SEE THE POWER SUPPLY MANUAL FOR DETAILED INSTRUCTIONS.**

8. Adjust the input voltage taps (TB-1)-(TB-6) to the same setting on both power supplies to set the output power level to 190 A. \pm 10 A.
9. The taps on (TB-1-3) labeled W,X,Y,Z are **coarse** adjustments with tap (W) being the lowest current and tap (Z) being the highest current. A coarse adjustment is an approximate twelve ampere step.
10. The taps on (TB-4-6) labeled 1,2,3,4 are **fine** adjustments with tap (1) being the lowest current and tap (4) being the highest current. A fine adjustment is an approximate four ampere step.
11. Be sure all the terminal block screws have been tightened, and the contact is clamping the copper conductor and not the insulator. Re-energize the unit using the main power switch.
12. Repeat steps 6 through 13 until the power supplies have been properly adjusted. When the adjustments are completed, replace the lower access panels.

FOCUS AND X-Y ADJUSTMENT INSTRUCTIONS FOR SYSTEMS w/ ELECTRIC FOCUS

NOTE

FAMILIARIZE YOURSELF WITH THE LOCATION AND IDENTIFICATION OF THE COMPONENTS OF THIS SYSTEM AND ALSO THE NORMAL OPERATION OF THE SYSTEM BEFORE ATTEMPTING ANY ADJUSTMENT OR SERVICE.

NOTE

COMPLETELY READ THROUGH AND HAVE A GOOD UNDERSTANDING OF THE PROCEDURES BEFORE ATTEMPTING TO SERVICE THIS SYSTEM. FAILURE TO DO SO MAY RESULT IN FATAL INJURY OR EQUIPMENT DAMAGE.

EQUIPMENT REQUIRED

1. ALLEN WRENCH, 5/32"
2. VERY DARK SUNGLASSES or #5 WELDERS GLASSES

WARNING

THE SUPER 10 SYSTEMS PROJECT A VERY INTENSE BEAM OF FULL-SPECTRUM LIGHT. THE USE OF DARK GLASSES WHILE ADJUSTING THE BEAM PARAMETERS ON A LIGHT COLORED REFLECTIVE SURFACE AT A CLOSE DISTANCE IS MANDATORY.

WARNING

NEVER LOOK DIRECTLY INTO A LIGHTED FIXTURE'S LIGHT SOURCE.

ADJUSTMENT INSTRUCTIONS

1. Loosen the positioning fasteners and point the lamphood toward a wall, ceiling, or other flat surface at least 10 feet away.
2. Locate the focus switch located on the control panel on the back of the lamphood housing.
3. Remove the front cowl and locate the X & Y adjustment holes located on the lower small sides of the fixture at the ends of the front spider arms.

WARNING

THE SUPER 10 SYSTEMS PROJECT A VERY INTENSE BEAM OF FULL-SPECTRUM LIGHT. CAUTION MUST BE TAKEN WHEN POINTING THE BEAM AT AN OBJECT AT A DISTANCE OF LESS THAN 100 FEET WITH THE FOCUS SET FOR A CONVERGING BEAM. COMBUSTIBLE OBJECTS AND OBJECTS WITH A DARK COLOR MAY UNEXPECTEDLY IGNITE IF CARE IS NOT TAKEN IN THE FOCUSING AND POSITIONING OF THE BEAM.

4. Energize the fixture and ignite the lamp.
5. Adjust the focus by moving the focus switch up or down to produce a diverging beam pattern with 2-3 clearly defined rings of light with or without an off center hot spot.
6. Adjust the X & Y adjustment screws using a 5/32" allen wrench to move the inner rings of light to create concentric rings with the hot spot at the center of the light field. Turning the adjustment screw clockwise will move the rings toward that adjustment axis and turning the screw counterclockwise will move the rings away from that adjustment axis.

FOCUS AND X-Y ADJUSTMENT INSTRUCTIONS (continued)

7. Readjust the focus screw to set the desired beam spread.
8. Replace the front cowl, reposition the lamp head and resecure the position locking fasteners.

XENON BULB MAINTENANCE

Allow the blowers to operate for at least (10) minutes after extinguishing the arc. This measure is *required* by the bulb manufacturer to comply with bulb warranty conditions.

In order to insure maximum bulb life, the following procedures should be followed every 75 - 100 hours of operation.

BULB ROTATION

If the fixture is used in a position other than pointed within 15% of vertical, the bulb should be rotated 1/3 of a turn to insure even deposition of the vaporized tungsten generated by the arc inside the bulb.

ADJUSTMENT PROCEDURES

1. Refer to the instructions for removal and installation of the bulb noting all warnings.
2. Follow the disassembly procedure for a fixture with the bulb installed steps 1 thru 5.
3. When rotating the bulb for removal, continue LIGHTLY pressing rearward on the bulb. The threads of the bulb will ride out of their current leads and drop into the next set of threads in the receiver block. When this happens, you will feel the bulb drop down into the receiver block.
4. Immediately stop turning the bulb and reverse direction to screw the bulb in at the new orientation.
5. Complete reinstalling the bulb per the "Bulb Installation" procedure.

POWER LEVEL ADJUSTMENT

Check the output power level of the system and readjust as necessary. Output may be increased to maintain light output as the bulb ages, but output must remain below 210 amperes. SEE POWER ADJUSTMENT PROCEDURES preceding.

LAMPHEAD MAINTENANCE

The SUPER 10 lamphead requires very little maintenance to keep it in good working order. Cleanliness is the most important element.

The reflector should be cleaned periodically with a soft, clean, lint free cloth to remove any dust from the reflecting surface. If excessively soiled, use of a mild commercial glass cleaner (Windex[®] or equivalent) is acceptable; USE NO ABRASIVE CLEANERS.

The xenon bulb should be checked occasionally for the presence of foreign material on the envelope. Any dirt or other foreign material should be removed promptly. Use only alcohol and a clean cloth to clean the bulb; rinse with distilled water and dry carefully. DO NOT touch the bulb with bare fingers, and observe all safety procedures when working around the bulb.

The inside of the lamphead and the impeller blades of the blower should be cleaned periodically, depending on the dust conditions at each installation. Although the blower motor may have oil ports, the bearings are factory sealed and require no lubrication.

Check all electrical connections periodically for tightness, especially the DC leads at the xenon bulb and igniter terminations.

Follow the instructions on Page 9 regarding periodic bulb rotation. After rotating a bulb, increase current to the maximum allowable level, and operate the bulb at this higher level for 10 to 12 hours. This period will re-excite the thorium in the cathode tip and allow the new arc pattern to establish. After the 10 or 12 hours, return the current setting to its previous level.

Always allow the lamphead blower to operate for at least ten minutes after extinguishing the bulb. Failure to do so will shorten bulb life.

LAMPHEAD WIRING DIAGRAM

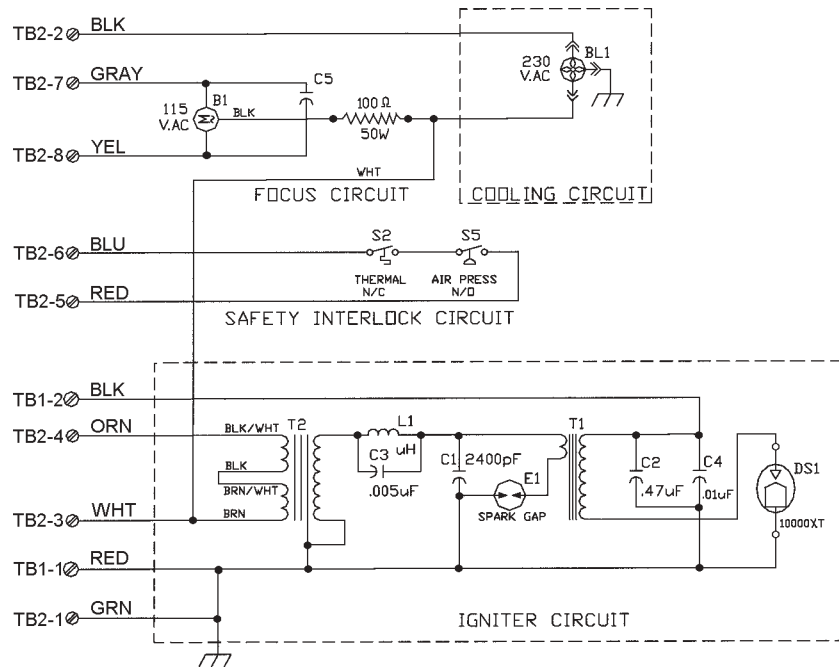

LAMPHEAD TROUBLE CHART

ALLOW THE LAMPHEAD TO COOL, with all blowers operating, for at least (20) minutes before opening.

Normal Operation:

The lamphead blower will start when power is first applied to the SUPER 10. When the control panel ON/OFF switch is in the "ON" position, the power supply blowers will start, and the AC circuit to the xenon power supply will energize the circuitry necessary to supply DC voltage to the igniter and bulb.

The DC open circuit ("no load") voltage will be detected by the igniter printed circuit board, which in turn will close the circuit to the igniter. There will be an audible high voltage arc ping at the spark gap in the igniter and at the xenon bulb. The bulb should ignite immediately after one or two of these high voltage pulses, and the lamp current will adjust to the sustaining level set at the xenon power supply. The STRIKE switch may be pressed to override a defective igniter PC board.

A reed switch, mounted to a printed circuit board and tie-wrapped to a DC output cable in the xenon power supply, will detect current flow and complete a circuit to the elapsed time meter. The elapsed time meter will record the unit's hours of operation.

Troubleshooting:

If the xenon bulb does not ignite, observe the following operational sequences for assistance in locating and isolating the trouble area.

When the three phase indicator lights are "ON," the AC circuit in the power supply is trouble free up to the terminal block (L1, L2, L3) in the power supply. Check the 230 V.A.C control circuit at the blower leads at TB2 terminals #2 and #3.

TROUBLESHOOTING (continued)

With the squirrelcage blower operating, the air plenum should compress, completing the circuit to the igniter. The hour meter should start to indicate elapsed time. If this meter does not operate, check for continuity at the SYSTEM switch. Check continuity of the air pressure switch; should read 0 Ohms between "NO" and "COM" when actuated. A defective elapsed time meter will not prevent bulb ignition.

With the SYSTEM switch in the "ON" position, a distinct high voltage arc ping at the igniter spark gap should be heard, and a flash from the xenon bulb should be visible, as DC voltage is applied to the bulb electrodes. If the high voltage ping or the flash at the ammeter is not apparent, check for 110 V.DC "No Load" voltage between the lamphouse and power supply. An adequate level of "no load" voltage will close the relay on the igniter PC board and fire the igniter. Momentarily pressing the STRIKE switch will bypass the igniter PC board.

If the correct voltage for the power supply is not measured, the problem is in the lamphouse/power supply interconnecting cable(s), or in the power supply. See the troubleshooting guide for additional instructions and tests.

If the high voltage arc is audible at the lamphouse, and the bulb does not flash, replace the bulb and attempt ignition with the new bulb.

Using the new bulb, if the high voltage arc is audible at the lamphouse, the flash of the bulb is visible, and ignition is not sustained, the problem is in the power supply.

If the high voltage arc is not audible or the flash of the bulb visible, the trouble is in the igniter or the igniter printed circuit board assembly.

Bulb fails to ignite.

1. AC power not on to lamphouse. If 230 V.AC not read at TB2-2 & 3, check power supply.
2. Air pressure switch S5 not closing. Check for unobstructed hose; clean if required. Check continuity between "NO" and "COM;" replace if defective.

Bulb fails to ignite; ping audible, bulb flash visible.

1. Inadequate DC output from xenon power supply. Set power supply output to correct range required for bulb wattage (165-210 A.).
2. Faulty or expired xenon bulb. Replace as required.

Bulb fails to ignite; ping audible, no bulb flash.

1. Faulty xenon bulb. Check for cracked electrodes or darkened envelope. Replace if defective.
2. Ignition pulse shorting to ground. Inspect DC leads for burned insulation; dress leads away from grounded metal components.

No high voltage ping audible; LAMP switch in "ON."

1. Loss of AC control voltage. Check xenon power supply for open thermal switch.
2. Little or no DC "No Load" voltage. Measure DC "No Load" voltage at rectifier "Test" jacks.
3. Defective igniter PC board. Press STRIKE switch to bypass; do not hold switch for longer than *one second*. Repair or replace PC board.
4. Defective "STRIKE" switch. Check for continuity across terminals.
5. Faulty igniter. Check for 230 V.AC at TB2-3 & 4; adequate DC "No Load" measured. Replace igniter if defective.

TROUBLESHOOTING (continued)

Bulb goes out during operation.

1. Xenon power supply overheated; thermal switch open. Check power supply blower(s), air inlets and outlets unobstructed.
2. Lamphouse blower BL1 overheated. Blower motor is thermally protected and will shut off if overheated; blower will re-start when temperatures fall to safe levels. Clean dust and dirt from blower squirrelcage.
3. Lamphouse blower BL1 defective or obstructed, allowing lamphouse thermal switch S2 to open. Check for 230 V.AC at TB2-2 & 3; clean or replace blower if defective.
4. Lamphouse air pressure switch S5 faulty. Check for correct actuation; inspect and repair pressure line, or replace switch as required.
5. Lamphouse thermal switch S2 faulty. Switch should not open below 325° F. (163° C.); replace as required.
6. Defective bulb. Check for scorched electrodes or discolored envelope.

Excessive light flicker.

1. Unstable arc following bulb rotation. Observe bulb current setting; increase current to 200-210 amperes. Operate bulb for ten to twelve hours at high current to sharpen cathode tip; return to previous current setting.
2. Faulty or aged bulb. Check for cracked or sagging electrodes; replace if defective.
3. Defective rectifier diode(s). Dismount and test diodes (see power supply manual); replace defective unit(s).
4. Excessive ripple in DC output. See power supply troubleshooting.

Reduced light output.

1. Darkened envelope caused by normal bulb aging. Increase output current. **DO NOT EXCEED MAXIMUM CURRENT SPECIFIED BY BULB MANUFACTURER.**
2. Soiled reflector. Clean using commercial glass cleaner. **USE NO ABRASIVES.**
3. Soiled cowl glass. Clean as required.
4. Leaking bulb. Check for high current and low voltage; white or bluish discoloration of envelope. Replace as required.

Extremely long duration between ignition pulses.

1. Low DC "No Load" from xenon power supply. Check "No Load" voltage; see power supply manual.
2. Defective spark gap E1. A "Ping" sound is normal; excessive "Hissing" is abnormal. Replace if defective.
3. Low AC voltage to lamphouse. Check for 230 V.AC at input; if below 190 volts, check AC source.

Elapsed Time Meter Fails to Record Hours.

1. Current Detector PCB not in contact with DC lead. PCB must be tie-wrapped to the insulation of one of the heavy DC output leads from the xenon power supply.
2. Defective component on current detector PCB. Repair or replace. Secure replacement board to DC lead as instructed in Step 1.
3. Defective hour meter, Replace as required.

FIGURE 1
Lamphead Assembly

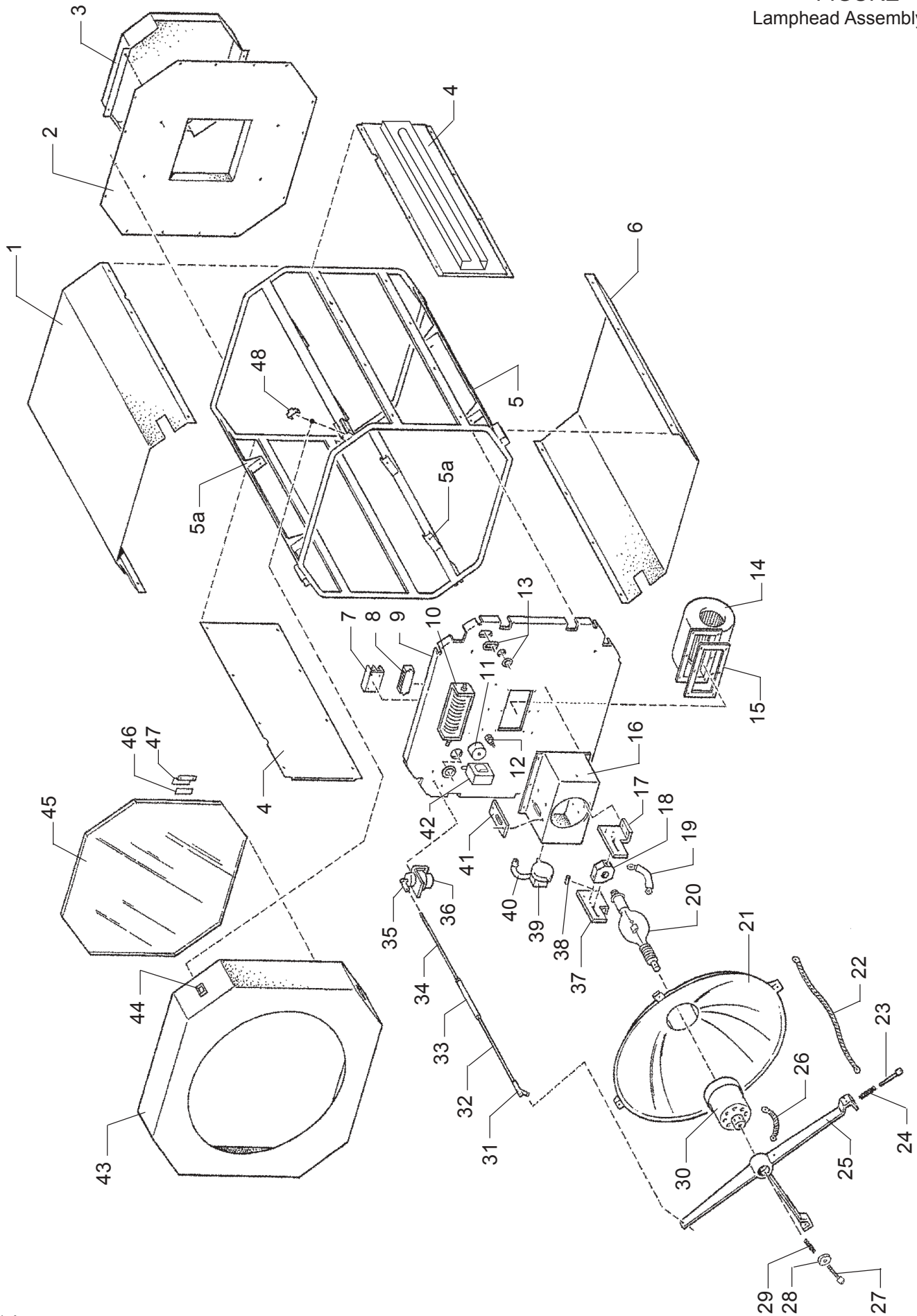

PARTSLIST

Figure 1

<u>Item</u>	<u>Part No.</u>	<u>Description</u>
1	32-00103	Top Cover
-	4100503	Mounting Screw, 10-32 x 1/2" Pan Head
2	32-00109	Rear Plate, Inner
-	4100503	Mounting Screw, 10-32 x 1/2" Pan Head
3	32-00109	Outer Cover, Welded Assembly
-	4100503	Mounting Screw, 10-32 x 1/2" Pan Head
4	32-00143	Side Cover & Slide Channel, Welded Assembly (2 req'd.)
-	4100503	Mounting Screw, 10-32 x 1/2" Pan Head
-	31-28035	"T" Handle Casting, Threaded 1/2-13 (not shown; 2 req'd.)
-	32-00145	Sliding Pivot Stud (not shown; 2 req'd.)
5	32-40639	Lamphead Frame, Welded Assembly
5a	32-40638	Mounting Bracket, Reflector/Bulkhead (8 req'd.)
6	32-00105	Bottom Cover
-	4100503	Mounting Screw, 10-32 x 1/2" Pan Head
7	31-62025	Terminal Block, DC
-	4100503	Mounting Screw, 10-32 x 1/2" Pan Head
8	31-62011	Terminal Block, AC
-	4100621	Mounting Screw, 10-32 x 5/8" Pan Head
9	32-40643	Bulkhead Plate
-	4250752	Mounting Screw, 1/4-20 x 3/4" Hex Head
-	4257000	Split Lockwasher, 1/4"
-	4257102	Flatwasher, 1/4"
10	32-50230	RF Coil (T1)
-	4080624	Mounting Screw, 8-32 x 5/8" Pan Head
11	39110000	Capacitor (C1)
-	4080256	Mounting Screw, 8-32 x 1/4" Pan Head
12	31-61009	Spark Gap (E1)
13	41-98127	Grommet Strip, 1/8" (order by foot)
14	32-70228	Squirrelcage Blower, 465 cfm, 220 V.AC, 50/60 Hz.
-	31-98182	Mounting Stud, Shockproof (6 req'd.)
-	4108001	Hexnut, 10-32
15	32-00020	Blower Gasket
16	32-40676	Air Plenum, Rear Bulb Support
-	4100503	Plenum Mounting Screw, 10-32 x 1/2" Pan Head
-	32-40288	Reflector Bonding Bracket, Short (not shown)
-	32-40289	Reflector Bonding Bracket, Long (not shown)
-	4250501	Bracket Mounting Screw, 1/4-20 x 1/2" Socket Head
-	4257104	Flatwasher, 1/4"
17	31-98769	Rear Bulb Receiver Bracket, Left
-	4251002	Mounting Screw, 1/4-20 x 1" Socket Head
18	32-50050	Rear Bulb Receiver, Threaded
-	4151755	Mounting Screw, 10-24; 3/8" Shoulder , 2 req'd.
19	32-00343	Negative Lead, RF Coil to Receiver
-	71928000	Insulator, Silastic Rubber
20	31-30244	Xenon Bulb (DS1), 10,000 Watt
21	32-50545	Reflector Assembly, 30" Parabolic
22	31-71025	Positive Lead, Bulkhead to Front Spider (2 feet req'd.)
-	31-62038	Ring Terminal, 1/4" Clearance
-	41-62092	Ring Terminal, 3/8" Clearance
23	4251750	Screw, 1/4-20 x 1-3/4" Socket Head
24	31-58025	Compression Spring
25	32-40293	Front Spider, Welded Assembly
-	31-61134	Thermal Switch (S2), open at 325° F. (not shown)

PARTS LIST, Figure 1 (continued)

<u>Item</u>	<u>Part No.</u>	<u>Description</u>
26	32-00012	Positive Lead, Spider to Bulb Holder (2 req'd.)
-	4250502	Contact Screw, 1/4-20 x 1/2" Hex Head, Brass
27	41-51767	Shoulder Screw
28	4317102	Washer
29	31-58006	Compression Spring
30	32-00026	Bulb Holder Assembly
-	4100750	Clamping Screw, 10-32 x 3/4" Socket Head (2 req'd.)
31	31-98131	Front Ball Joint
-	41-98096	Hex Spacer
-	4108002	Locknut, 10-32
32	32-20327	Threaded Rod, Front
33	32-20322	Turnbuckle
-	4108001	Hexnut, 10-32 (2 req'd.)
34	32-20328	Threaded Rod, Rear
35	31-98133	Rear Ball Joint
-	4100500	Screw, 10-32 x 1/2" Socket Head
-	32-20019	Cam (mounts to Motor Shaft)
-	4080509	Cam Set Screw, 8-32 x 1/2"
36	32-70328	Motor Assembly (with Bracket & Cam)
-	31-33027	Gearmotor, 115 V.AC, 50/60 Hz.
-	11-46001	Resistor, 100 Ohm, 50 W. (not shown)
-	32-40720	Motor Mounting Bracket
-	4100500	Mounting Screw, 10-32 x 1/2" Socket Head
-	4107000	Split Lockwasher, #10
37	31-98770	Rear Bulb Receiver Bracket, Right
-	4251002	Mounting Screw, 1/4-20 x 1" Socket Head
38	31-37026	Roll Pin (incl. with Item 18 Receiver)
39	31-61078	Pressure Switch (S5)
-	4100503	Mounting Screw, 10-32 x 1/2" Pan Head
40	32-20324	Hose, Pressure Line (7 inches req'd.)
-	31-20001	Hose Fitting (2 req'd.)
41	32-40287	Insulator Plate
-	4080624	Mounting Screw, 8-32 x 5/8" Pan Head
42	32-70339	Transformer (T2)
-	4080624	Mounting Screw, 8-32 x 5/8" Pan Head
-	4087101	Flatwasher, #8
-	4087000	Split Lockwasher, #8
43	32-00104	Front Cowl, Welded Assembly
44	31-18004	Push Latch (4 req'd.)
-	31-18005	Latch Shim (4 req'd.)
45	31-98777	Glass, Front Lens
-	11-98069	Silicone Sealant, RTV 736 (3 oz. tube)
46	32-20331	Pad (8 req'd.)
47	324-0285	Mounting Bracket (8 req'd.)
-	4080371	Mounting Screw, 8-32 x 3/8" Flat Head
-	4100503	Mounting Screw, 10-32 x 1/2" Pan Head
-	32-00110	Cowl Assembly (Items 43-47, Complete)
48	32-40698	Catch, Cowl Latch (4 req'd.)
		NOT SHOWN
	32-70331	Lamphead Wire Harness Assembly
	31-40008	Strain Relief Bushing
	32-40535	Lamphead Yoke, Welded Assembly
		Yoke Mounting Screw, 3/4-10 x 1-3/4" Hex Head

Strong Entertainment Lighting

EQUIPMENT WARRANTY

Strong Entertainment Lighting agrees that its products shall be free from defects in materials and workmanship for a period of one (1) year from the date of original shipment from its factory. This warranty is nontransferable and applies to the original purchaser only. Said warranty will not apply if equipment is used in conditions of service for which it is not specifically intended. Strong is not responsible for damage to its apparatus through improper installation, physical damage or poor operating practice.

If any device is found to be defective under the warranty, the buyer should notify the manufacturer. Such equipment will be repaired or replaced, at manufacturer's option, free of all charge except transportation, F.O.B. its factory. Any such repair or replacement by the manufacturer shall constitute fulfillment of all obligations to the purchaser. This warranty does not include troubleshooting expense, labor charges associated with service calls, and disassembly or reassembly of the lamp system. Should such a repair or replacement require an on-site service call, the Purchaser shall bear the responsibility for all costs and associated expenses. The manufacturer does not assume responsibility for any unauthorized repairs to its products, even though defective, and unauthorized parts or repairs shall void this warranty.

This warranty is the only warranty given with the manufacturer's products. There are no warranties of merchantability of fitness for a particular purpose or other warranties or representations of any kind, express or implied, which are made with respect to these products.

The remedies of the Owner set forth in this warranty are exclusive. In no event shall the buyer be entitled to recover for incidental, special or consequential damages arising from the sale or use of these products, including but not limited to loss of profits or revenue, other commercial losses, inconvenience, delay, labor, repairs, or other cost of rental or replacement equipment.

This warranty excludes any and all incidental damage that may be caused by xenon bulb explosions. The bulbs used in Strong products are not included in this warranty; however, they are covered by the bulb manufacturer's warranty.

