

INSTRUCTION MANUAL

XENON GLADIATOR II

Follow Spotlight

Type 47050

Rev. May 2004



STRONG INTERNATIONAL

a division of Ballantyne of Omaha, Inc.
4350 McKinley Street
Omaha, Nebraska 68112 USA
Tel 402/453-4444 • Fax 402/453-7238

PREFACE

THE STRONG INTERNATIONAL XENON GLADIATOR II Model 47050 is a direct current follow spotlight complete with a xenon lamphouse, power supply, optical system, color boomerang, and base stand assembly. The spotlight assembly consists of the arc lamp, variable focus lens system, color boomerang, and base. The separate xenon power supply completes the installation.

ONLY THE SPECIAL XENON POWER SUPPLIES manufactured by Strong International can be used with the Gladiator II. For installation and operation of the power supply, see the instruction manual furnished separately.

THE XENON LAMPHOUSE utilizes a 2500 watt xenon bulb designed for horizontal operation, and a deep ellipse metal reflector as a light source. The reflector is designed to operate in a fixed position, and is dichroic ("cold") coated to reduce heat in the projected light. A lens blower and heat filters, mounted in the spotlight optical system, further reduce heat at the projection lens and color media.

ONLY XENON BULBS designed for horizontal operation should be used in this follow spot. Those bulbs presently approved for the Gladiator II include the Hanovia® XH2500HS, the Osram® XBO2500W/HS OFR, and the ORC® XM2500HS. All required bulb cabling is provided in the xenon lamphouse, and bulb adapters are not required.

ADJUSTMENT CONTROL for the xenon bulb is located at the rear of the lamphouse behind the access panel. The adjustments control the horizontal, vertical and focal movement of the bulb.

INSTRUMENTATION of the lamphouse includes a running time meter and a DC ammeter. The running time meter indicates the number of hours the bulb has been in operation. The ammeter displays the operating current of the lamp. A push button switch, located below the ammeter, changes the meter reading to indicate the DC voltage at the arc.

THE LAMPHOUSE COOLING BLOWERS are internally wired and operate on AC voltage derived from the xenon power supply. These blowers are required to maintain a safe operating temperature at the bulb seals. The blowers operate continuously until the xenon power supply is de-energized. Air flow interlock switches prevent operation of the lamp if the intake or exhaust blowers are not operating or failing to move adequate air.

THE IGNITER is equipped with an emergency ignition switch, located on the top of the lamphouse below the plug button. Pressing this switch bypasses the relay contacts on the igniter printed circuit board. DO NOT hold this switch for longer than **one second** to prevent transformer damage.

THE TWO ROCKER SWITCHES on the instrument panel are labeled MODE and LAMP. The MODE switch permits operation of the lamphouse from a remote location when placed in the "AUTO" position, or by the operator at the lamphouse when in "MAN." The normal setting for this switch, in a follow spot application, is in the "MAN." position.

THE LAMP SWITCH is provided for manual bulb ignition when the MODE switch is in the "MAN." position. The LAMP switch must also be "ON" to complete the ignition circuit when operating from a remote location.

THE LAMPHOUSE is supplied with a 13 foot cable containing the DC leads, the AC control wires, and the ground wire. The cable terminates in a multiple pin MS connector keyed to mate with the receptacle on the power supply.

WHEN TRANSPORTING THE SPOTLIGHT, it is necessary to remove the xenon bulb and place it in its original shipping container to prevent breakage. See the SAFETY PROCEDURES section following, and permit only authorized personnel to handle the xenon bulb.

IF AT ANY TIME you have a suggestion, or desire aid in securing anticipated results, write directly to STRONG INTERNATIONAL, 4350 McKinley Street, Omaha, Nebraska 68112.

INSTALLATION AND SETTING UP SPOTLIGHT

THE XENON GLADIATOR II is shipped in sections which must be assembled. Lifting straps on the yoke assembly permit assembling the spotlight on the floor and later hoisting it to an elevated position.

ASSEMBLE THE FOUR BASE LEGS to the lower square section of the base column using the 3/8-16 x 2-3/4 inch hex head cap screws and lockwashers provided. Insert a leveling foot and locknut in each of the four leg brackets and level the base before continuing the installation.

WHEN INSTALLED in a permanent location, the leveling feet must be removed, and the clearance holes in the base leg brackets used for hardware (user supplied) to bolt the base to the floor or platform. If it is desired to have the unit portable, when operating, the leveling feet *must* be adjusted down until the weight of the spotlight has been shifted from the casters to the leveling feet.

THE INNER TUBE and support yoke has three holes to permit adjusting the height of the spotlight. The three holes are on four inch centers and will allow an optical height of approximately 53 inches, 57 inches, and 61 inches above floor level to the optical center of the lamphouse and lens system. The leveling feet may be adjusted through an additional two inch range. Insert the height location pin through the hole in the outer tube and one of the holes in the inner tube.

THE HORIZONTAL SWING and vertical tilt locking knobs are on the right hand (operating) side of the yoke assembly. Tighten both of these locking devices securely before attempting to place the lamphouse and lens system on the support yoke.

PLACE THE LAMPHOUSE and lens system on the yoke assembly, with the spot size control handle to the right hand (operating) side, the same as the locking controls on the yoke. Line up the four mounting holes in the bottom of the base rail with the four mating holes in the support yoke and secure using the four sets of 3/8-16 screws, nuts and washers.

ATTACH THE LAMPHOUSE CABLE CONNECTOR to the mating receptacle on the power supply. The lamphouse and power supply connectors are keyed for correct pin alignment; make certain pins are seated before tightening the locking ring. Check the position of the slide switch adjacent to the MS connector; it must be in the proper setting for "Lamphouse/Spotlight". See the inside front cover of the power supply manual. DO NOT energize the xenon power supply before the xenon bulb is correctly installed into the lamphouse.

EARLIER MODELS of Strong xenon spotlights included a heavy-gauge green ground wire in the lamphouse cable assembly. This ground wire was attached to a ground stud connected to the power supply cabinet. Current models of Strong power supplies include a 1/4-20 stud in the cabinet adjacent to the MS connector to allow ground termination of older spotlights.

LAMPHOUSE - POWER SUPPLY

Interconnection Diagram

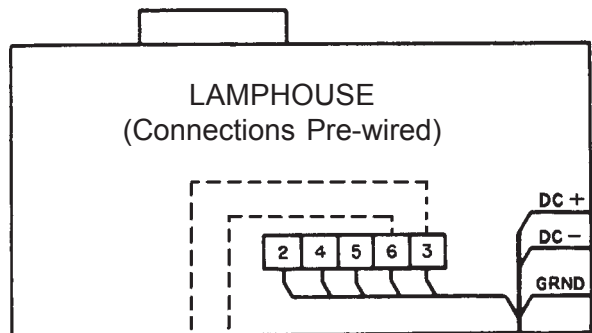

MS CONNECTOR

| Pin | Wire No. |
|-----|----------|
| A | DC- |
| B | DC+ |
| C | 2 |
| D | 3 |
| E | 4 |
| F | 5 |
| G | 6 |
| I | 7 |
| J | 8 |
| M | Grnd |

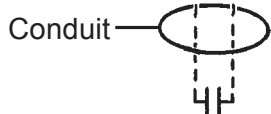
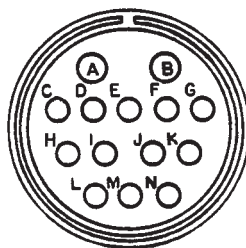

Remote - Auto Sustained 5 Amp. Dry Contact
(by Installer as req'd.)



SYSTEM MUST BE GROUNDED
All wiring must conform to local codes; shield lamphouse cable in conduit if required.

Check Slide Switch (below) on Power Supply for correct positioning.

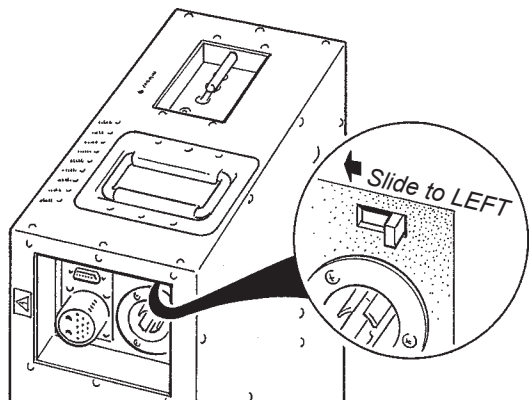
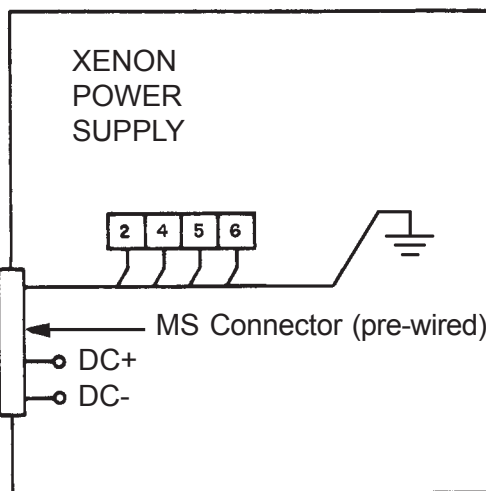

SAFETY PROCEDURES



READ CAREFULLY BEFORE INSTALLING XENON BULB



THE XENON BULB is highly pressurized. When ignited, the normal operating temperature of the bulb increases the pressure to a level at which the bulb may explode if not handled in strict accordance to the manufacturer's operating instructions.

THE BULB is stable at room temperature, but may still explode if dropped or otherwise mishandled. Breakage resulting from transport and handling is *not* covered by the bulb manufacturer's warranty, and it is strongly recommended to dismount the xenon bulb when transporting the spotlight.

REFER bulb replacement and service to QUALIFIED PERSONNEL with adequate protective clothing (face shield, clean cotton gloves, welder's jacket). For routine lamphouse service, observe the following rules:

1. Allow the bulb to cool to room temperature before opening the lamphouse. Put on protective clothing described above.
2. De-energize the xenon power supply at the AC source before opening the lamphouse compartment.
3. When possible, encase the bulb in its protective cover when cleaning or servicing the lamphouse interior. The bulb, when outside the lamphouse, must be encased in the cover.
4. Clean the bulb after it has cooled to room temperature. Do not touch the quartz envelope of the bulb; fingerprints will burn in and create hot spots which may shorten bulb life. If fingermarks are made, they should be carefully removed with methyl alcohol and cotton prior to bulb operation.
5. Never view an ignited bulb directly. **BLINDNESS OR PERMANENT EYE DAMAGE MAY BE INCURRED.**
6. Use only xenon bulbs designated as OZONE FREE. When possible, vent the lamphouse exhaust to outside atmosphere.
7. Maintain the lamphouse blower in good operating condition. Keep the blower inlet clean for unrestricted air flow.
8. To insure maximum bulb life, operate the lamphouse blower and the exhaust system for **at least** ten minutes after extinguishing the bulb.
9. If returning a bulb for warranty adjustment, pack it in its original shipping container. Complete and return all required warranty information.

10. Dispose of expired bulbs that are beyond warranty in the following manner: Wrap the bulb tightly in several layers of canvas or heavy cloth. Place it on a hard surface and shatter the envelope with a sharp hammer blow. DO NOT place an unshattered bulb in an ordinary refuse container.
11. DO NOT PERMIT UNAUTHORIZED PERSONNEL TO PERFORM OR ATTEMPT ANY PHASE OF XENON BULB HANDLING OR SERVICE.

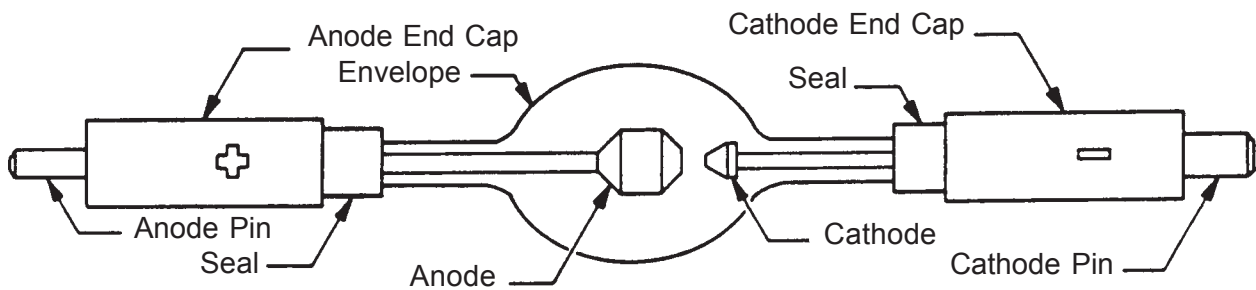

BULB INSTALLATION

OBSERVE ALL SAFETY PROCEDURES when working around the xenon bulb. Open the lamphouse access door by removing the tamperproof screws using the special screwdriver supplied. The igniter lead and contact clamp are tied off for shipping. Free the clamp and slide it over the rear bulb support collet.

THE BULB SUPPORT YOKE in front of the reflector has three horizontal positioning holes to permit setting the height of the yoke. The Gladiator II uses only the upper two holes. The spotlight is shipped set up for use with the Hanovia XH2500HS bulb normally supplied with the unit, and the spring pin is through the top hole. Because of a different end cap dimension, the bulb yoke must be raised and the pin installed in the center hole if an Osram XBO2500W/HS bulb is used. The yoke may be repositioned by loosening the 8-32 set screw in the support post. Tighten the set screw after setting the yoke position.

REMOVE THE PLASTIC PROTECTIVE COVER from the xenon bulb only if necessary. Handle the bulb by the metal end caps *only*. Insert the bulb into the lamphouse, passing the anode (+) end cap through the center hole of the reflector. Take care not to bump or scratch the surface of the reflector.

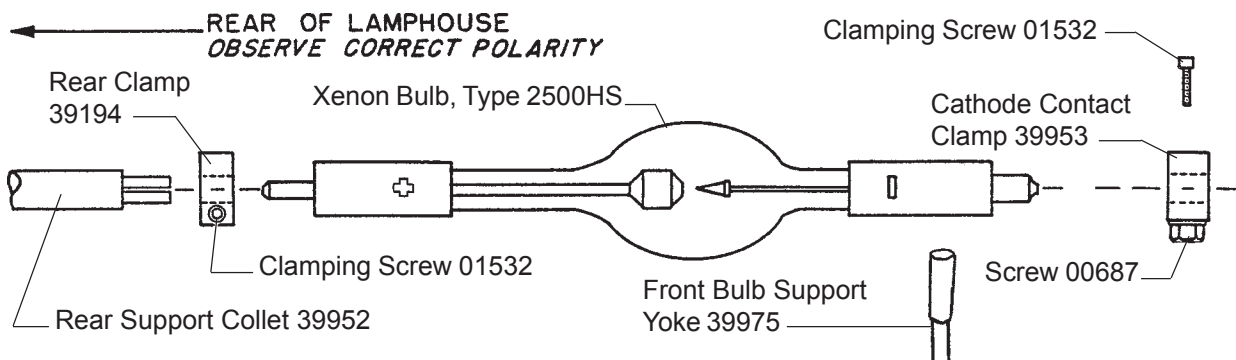

INSERT THE ANODE (+) PIN into the rear support collet and contact clamp. Rest the cathode (-) end cap in the front bulb support yoke. Seat the anode (+) pin into the rear support collet as far as possible for correct focus travel. Securely tighten the socket head clamping screw in the anode contact.

REST THE CATHODE END CAP in the "V" of the bulb yoke. Install the cathode contact clamp over the cathode (-) pin. Firmly tighten the socket head clamping screw for a secure electrical contact. Dress the negative DC lead attached to the contact clamp directly in front of the bulb support yoke to minimize the projected shadow.

RECORD the bulb serial number, date, and lamphouse hours on the Xenon Bulb Record on the inside back cover of this manual. This information will be needed in the event of a bulb warranty adjustment.

IT IS RECOMMENDED to use the above-mentioned lamphouse cables when installing the xenon bulb. Anode leads supplied with bulbs are generally removable. If it is necessary to use the bulb anode lead, remove the lamphouse igniter lead, and use the clamp to secure the bulb to the support collet. Attach the bulb lead terminal to the igniter post; insulate the lead well and dress the lead away from grounded lamphouse components.

ESTABLISH A ROUTINE of periodically checking all electrical connections for tightness. Loose contacts, particularly in the DC circuit, will cause overheating and damage the xenon bulb and other components. Normal xenon bulb warranties allow **no credit** for bulb damage caused by overheating.

REFER TO THE BULB MANUFACTURER'S INSTRUCTIONS regarding bulb rotation. Most bulb manufacturers recommend rotating the bulb 180° at 50% of warranty hours. After rotating the bulb, operate at maximum allowable current for several hours, and then return to the nominal operating current.

IN THE EVENT of a bulb warranty claim, the bulb must be packaged in its original shipping container, and returned with all required warranty forms completed. Contact the dealer through whom the bulb was originally purchased for correct procedures and Return Authorizations.

IT IS A COMMON PRACTICE to replace the bulb at the expiration of its warranty period. If a xenon bulb explodes in operation, the reflector and other lamphouse components are frequently damaged. The xenon bulb manufacturer will extend *no credit* for a replacement reflector if the defective bulb is beyond warranty. Explosion-damaged reflectors are to be returned to the **bulb supplier**, NOT Strong International, unless the bulb was supplied by Strong.

ARC STABILIZATION MAGNET

THE XENON BULB used in the Gladiator II lamphouse requires an arc stabilization magnet. This magnet is located on the lamp base behind the reflector. This magnet is preset at the factory and should not require adjustment. Should it become necessary to adjust the magnet, the following procedure must be followed. Observe all bulb safety procedures when working in the lamphouse compartment.

THE NORMAL ARC, when viewed through the arc viewing port, will appear as in Figure "A." This represents the correct magnet position. Figure "B" shows the position of the arc when the magnet is too low. Raise the magnet on its adjustment bracket to lower the arc to the position illustrated in Figure "A." Figure "C" shows the position of the arc when the magnet is too high. Lower the magnet to raise the arc to the position illustrated in Figure "A."

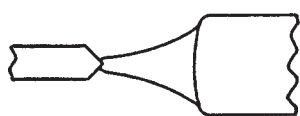

FIGURE A

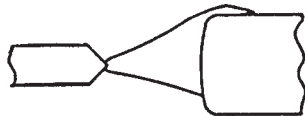

FIGURE B

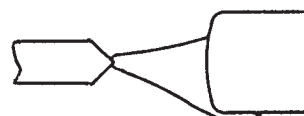

FIGURE C

THE MAGNET must always be installed with the longest portion of the magnet nearest the bulb, and with the NORTH (N) pole pointing to the operator side access door. Reversing the magnet will cause bulb flicker, and may inhibit bulb ignition. In new equipment, the magnet is normally in the center of the adjustment range. Changes in the magnet position are required *only* to correct an improperly burning arc (Figure "B" or "C").

ANY REPLACEMENT MAGNET should first be installed in the center position of the adjustment range. Raise or lower the magnet as required to center the arc as illustrated in Figure "A."

OPERATION

INSTALL THE GLASS HEAT FILTER into the bracket mounted on the rear of the fadeout and douser support housing. NOTE: The *coated side* of the filter, with the XX or other marking, **must be facing the reflector**. Reach through the side door and nose opening of the lamphouse, slide the filter into the slot in the top angle bracket, and lower it into the bottom slotted bracket.

REMOVE THE PLASTIC COVER from the xenon bulb. DO NOT ignite the lamp with the cover on the bulb. Store the cover for future re-use.

CLOSE AND SECURE the lamphouse door using the tamperproof screws and special screwdriver supplied with the lamphouse. Engage the cam lock and install the security screw. The door must be completely secured to actuate the interlock switch and permit lamp ignition. Place the MODE switch in the "MAN." (manual) position.

TURN ON THE MAIN LINE SWITCH and/or circuit breaker to energize the xenon power supply. The lamphouse blowers will start and the blower interlock switches will be actuated to permit lamp ignition. The blowers will operate continuously until the xenon power supply is de-energized.

PLACE THE **LAMP SWITCH** in the "ON" position and the lamp will ignite. If ignition does not occur, or the high voltage pulse is not apparent, press the emergency ignition switch on the top of the lamphouse under the plug button. Do not hold more than **one second**; release immediately upon lamp ignition. Use of the emergency ignition switch indicates an abnormal condition; see the TROUBLESHOOTING section following.

CHECK THE READING on the lamphouse ammeter. Nominal current for the 2500 watt xenon bulb is 90 amperes. DO NOT, AT ANY TIME, exceed 100 amperes. Output current is adjusted at the power supply; see power supply manual for instructions. Operation of a new bulb is normally started at the lower end of its range (80 A.), and current is gradually increased as the bulb ages to maintain light output.

PRESS THE SMALL PUSH BUTTON SWITCH located below the ammeter to read the DC voltage at the arc. This permits immediate calculation of the power at which the lamp is operating (volts x amperes = wattage). Holding this switch in during the ignition cycle will also briefly indicate the "no load" (open circuit) DC voltage applied to the xenon bulb for ignition.

REMOVE THE REAR COVER PLATE below the instrument panel by withdrawing the two plastic plungers. This exposes the bulb positioning controls in the lamphouse back casting.

TO FOCUS THE XENON BULB and obtain the best light on the stage, the two methods outlined below are the most suitable.

MOVE THE SPOT SIZE CONTROL HANDLE (trombone) on the large lens carriage all the way forward to project the smallest spot possible; place the iris, masking shutters (choppers) and the fadeout douser blades in their full open positions. Project a spot to a wall or similar flat perpendicular surface opposite the spotlight position.

THE CENTER SECTION of the bulb positioning controls is a threaded member that focuses the bulb in relation to the reflector. Turning this adjustment moves the bulb in only one plane, into or away from the reflector. Turning this section clockwise moves the bulb away from the reflector. The small knurled screw to the left of this section can be tightened to lock the focusing mechanism after the following procedures have been completed.

THE LARGE THUMB SCREWS, on either side of the focusing control, lock the horizontal and vertical adjustment mechanism in position.

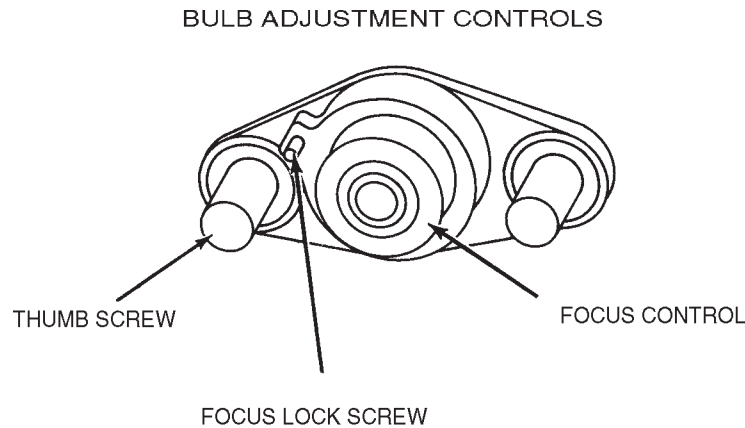

TURN THE CENTER FOCUSING SECTION of the bulb positioning control counterclockwise until a small black spot is projected onto the wall. It may be best to run this adjustment both directions to permit positive identification of the spot.

LOOSEN THE TWO THUMB SCREWS, one on either side of the center focusing section, just enough to permit manual movement of the complete assembly. The bulb positioning control will now move around these two thumb screws, and as this control is shifted, the smooth shadow of the bulb electrode can be seen extending beyond the projected center hole in the reflector. The shadow of the electrode (black spot) must be centered in the projected hole of the reflector (shaded, less dense dark area).

MOVE THE CONTROL SECTION around the two screws until the black spot is as round as possible to project. It may be necessary to again turn the focus control to project a sharply defined black spot.

AFTER THE BLACK SPOT is as even around the outside as possible to project, and appears centered in the shaded reflector center hole, tighten the two large thumb screws to lock the position of the mechanism. Turn the center focus control to obtain the brightest light with the best light distribution. Rotate the lens spot focus control knob, located at the extreme front of the lens mechanism, to obtain the sharpest edge possible on the projected spot.

THE SECOND METHOD of focusing the xenon bulb is to project the spot to the stage, and working with the above lamphouse controls, adjust these controls to obtain a “hot spot” on the projected spot. Then center this “hot spot” on the projected light by moving the entire control section around the two thumb screws. Once this “hot spot” is centered in the projected light, lock the control in position with the two thumb screws and turn the center section to obtain a spot with an even distribution of light. Rotate the lens spot focus control knob to obtain a sharp edge on the projected spot.

THESE ADJUSTMENTS should not be disturbed until it is necessary to replace the xenon bulb. At that time, the procedure on obtaining a smooth, round black spot, or "hot spot," may have to be repeated. Replace the cover plate over the bulb positioning controls.

BECAUSE OF NORMAL BULB AGING, and manufacturing tolerances between individual xenon bulbs, it may be necessary to operate lamps at slightly higher or lower current settings to maintain uniform light output when two or more spotlights are used in one installation. This entails a slight current output adjustment at the xenon power supplies. See the power supply manual.

TO EXTINGUISH the arc, place the LAMP switch on the instrument panel to "OFF." The lamphouse blowers will continue to operate until the xenon power supply is de-energized. Allow the blowers to operate for ten minutes before turning off the power supply; a forced-air bulb cooling cycle is *required* by all bulb manufacturers.

DAILY OPERATION in the "Manual" mode requires only that the xenon power supply be energized, the MODE switch be left in the "MAN." position, and the lamp switched ON and OFF by means of the LAMP switch. No bulb alignment or "warm up" are necessary. Always allow for the ten minute bulb cooling cycle.

OPERATION IN THE "AUTO" MODE is intended for use only if the spotlight is to be used as a fixed spot without an operator at the equipment. Place the MODE switch in the "AUTO" position, and the LAMP switch to "ON." The lamp will ignite when a sustained dry contact is made between the automation leads 3 and 6, and extinguish when the contact is opened. See the INSTALLATION DIAGRAM in the power supply manual. The lamphouse blowers will operate until the xenon power supply is de-energized; allow for ten minutes bulb cooling.

BEFORE OPENING the lamphouse enclosure for servicing, allow the blowers to operate for twenty minutes, or until the bulb has cooled to room temperature.

HANDLING THE SPOTLIGHT

GENERALLY THE BEST POSITION for the operator to stand is near the center of the spotlight on the right side. The angle of tilt, the size of the porthole, and the layout of the spotlight position may dictate another location.

EACH OPERATOR will, after a few minutes of operation, generally develop his own system and position for most convenient operation.

THE HORIZONTAL SWING and vertical tilt are individually adjustable to give the desired degree of friction to suit the operator. The locking clamps are located on the right side of the yoke assembly.

THE EASE with which the spot size control handle ("trombone") can be operated may be adjusted by means of the nylon friction brake screw in the outrigger of the large lens carriage casting. To access this adjustment, open the color boomerang and remove the gel frames. Slide the large lens carriage to the extreme rear position. Reach through the boomerang housing and loosen the nylon friction screw locknut. Turn the nylon friction screw clockwise to increase drag, or counterclockwise to relieve. Tighten the locknut after the desired adjustment is reached.

OPERATION OF OPTICAL SYSTEM

THE IRIS CONTROL is the front lever which projects through the top of the optical system housing. When this lever is to the left (as viewed from the rear of the unit), the largest aperture is provided. Smaller apertures are obtained as the lever is moved to the right.

THE SPOT SIZE CONTROL HANDLE is located on the right hand side of the optical system just above the base rail. A variation of spot sizes from full flood to small spot can be obtained by moving the spot size control handle from one extreme to the other. Beam intensity is increased by this optical system when reducing from flood to spot, and maximum intensity is reached when the spot size control handle is in the extreme forward position.

THE MAXIMUM FLOOD SPOT is obtained with the iris control lever to the left (away from operating side) for the largest aperture and with the spot size control handle moved as far to the rear as possible.

SMALLER SIZED SPOTS are projected as the spot size control handle is moved forward. Most of the spot sizes needed will be produced with the iris in its maximum open position.

FOR A "HEAD SPOT," or any spot smaller than can be obtained with the spot size control handle in its extreme forward position, shift the iris control lever to the right (toward operating side) for a smaller aperture. The iris control lever should always be returned to its extreme left position before the spot size control handle is again moved to obtain larger spots.

THE MASKING SHUTTER (chopper) lever is the middle lever projecting through the top of the optical system housing. The masking shutter blades are operated by this lever to shape the projected spot to a rectangle, strip spot, or dousing.

THE DISENGAGED POSITION of the masking shutter lever is to the extreme right (toward operating side) and varying degrees of masking to complete cutoff are obtained by moving the lever to the left (away from operating side).

THE ANGLE of the masking shutter blades can be adjusted to compensate for the horizontal projection angle. Remove the color boomerang and optical system housing, and loosen the screws holding each of the masking shutter blades enough to allow adjustments. Ignite the bulb and adjust the angle of the *bottom* blade by tapping with a screwdriver so its projected edge lies parallel to the footlights. Tighten the screw. Operate the masking shutter lever to close the blades. Adjust the upper blade to close in line with the bottom blade and tighten the screw.

THE FADEOUT MECHANISM AND DOUSER CONTROL is the rear lever projecting through the top of the optical system cover. This lever controls the intensity of light from complete fadeout when the lever is to the left, to full intensity when the lever is to the right.

THE SPOT FOCUSING CONTROL KNOB is located on the operating side of the optical system at the forward end above the base rail. This control is used to adjust the optical system for the length of throw. When making an adjustment, rotate the spot focusing control knob until the sharpest edge is obtained on the projected spot.

OPERATION OF COLOR BOOMERANG

THE COLOR BOOMERANG is equipped with six color holders and an ultraviolet filter. Additional filter holders can be supplied by an authorized Strong International Dealer.

TO OPERATE INDIVIDUAL COLOR FILTERS, lower the desired filter selector lever. A rocker catch located in the color disc housing holds the filter in position.

TO RELEASE A COLOR, push the filter release button or engage another color, thus releasing the previous color automatically.

TO REPLACE A FILTER HOLDER, open the hinged top of the color disc housing and lift out the desired filter holder.

HIGH TEMPERATURE FILTERS (RoscoLux® or equivalent) cut to nine inch diameter are required, and are secured in the filter holders with paper fasteners.

NOTE: WHEN PLACING COLOR FILTERS in the boomerang, the *less* dense colors (pink, amber) should be placed in the holders toward the **rear** of the boomerang (toward arc), and those of *greater* density (red, green) should be placed in the holders toward the **front** of the boomerang (away from the arc).

COLOR TEMPERATURE REDUCTION FILTERS, required for use with television and videotape, are available from theatrical supply dealers.

MAINTENANCE

THE XENON GLADIATOR II SPOTLIGHT requires very little maintenance to keep it in good working order.

THE REFLECTOR should be cleaned periodically with a soft, clean, lint-free cloth to remove dust from the reflecting surface. If excessively soiled, the reflector may be cleaned with Windex® or an equivalent glass cleaner. DO NOT use abrasive cleaners of any kind. Clean the heat filter glass; replace with the coated surface toward the lamphouse.

CHECK ALL ELECTRICAL CONNECTIONS for tightness on a regular basis. Loose connections, particularly in the DC circuit, may cause premature bulb failure and damage lamphouse components.

LUBRICATE the bulb seal blower and the lens blower with two or three drops of non-detergent oil once every six months. The exhaust blower is permanently lubricated.

THE XENON BULB should be checked occasionally for the presence of dust or foreign materials. If necessary, clean the quartz envelope of the bulb with alcohol, and wipe dry with a clean, lint-free cloth. Observe all safety procedures when working with the exposed bulb.

THE INSIDE OF THE LAMPHOUSE and the blower squirrelcages should be cleaned periodically, depending on the dust conditions at each installation. Keep the blower inlet and outlet grilles clean to permit free air flow. Clean the actuator arms of the air flow switches to prevent dust build-up.

THE LENS SYSTEM should be kept clean to prevent any light reduction in the projected spot. Tighten the horizontal swing and vertical tilt locking clamps. Remove the color gels to reach and clean the back surface of the large lens. Remove the cover casting over the fadeout, chopper, and iris controls to remove the small projection lens which is held in place with a large spring-type retainer ring at the front of the lens barrel.

CLEAN THE PROJECTION LENS and large lens with with any cleaner approved for use on coated projection lenses. Replace the Buhl projection lens with the end with the FL marking ring toward the iris; the ISCO lens tube has arrows indicating the end nearest the iris. Secure with the retainer ring.

BEFORE TRANSPORTING the spotlight, remove the xenon bulb from the lamphouse. Place the bulb in its plastic cover and original shipping container.

LAMPHOUSE SCHEMATIC

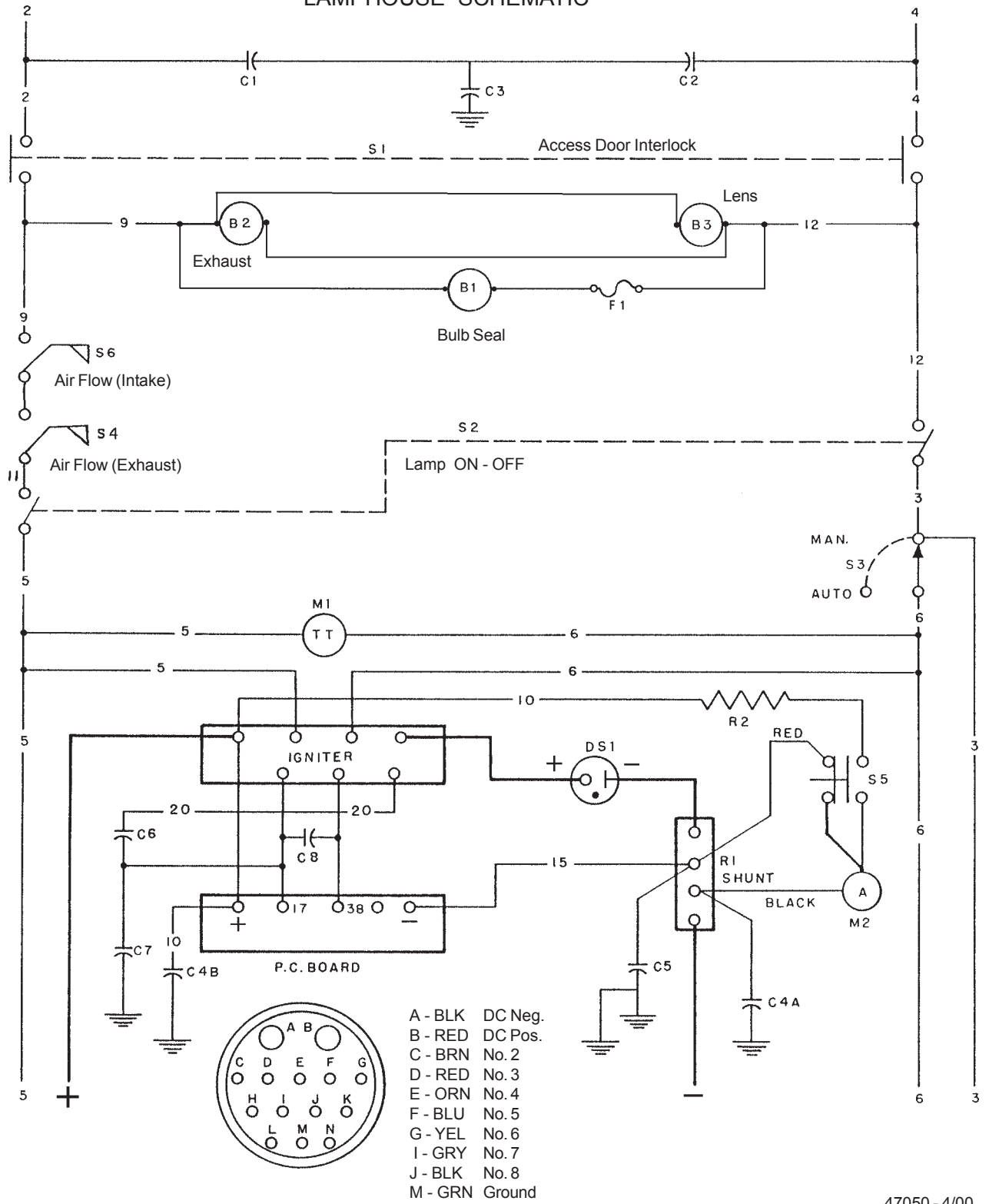

47050 - 4/00

PARTS LIST
Lamphouse Schematic

| Ref. | | |
|---------------|-----------------|--|
| <u>Desig.</u> | <u>Part No.</u> | <u>Description</u> |
| B1 | 39938 | Bulb Seal Blower Assembly, 115 V.AC, 50/60 Hz. |
| - | 21-21015 | Fuse, 1.5A. (F1) |
| B2 | 71220 | Exhaust Blower, 115 V.AC, 50/60 Hz. |
| B3 | 47944 | Lens Cooling Blower, 115 V.AC, 50/60 Hz. |
| C1,2 | 76132 | Capacitor, .005 μ f, 600WVDC * |
| C3 | 76133 | Capacitor, .01 μ f, 400 WVDC * |
| C4A, 4B | 80177 | Capacitor, 1.0+1.0 μ f, 600 WVDC |
| C5 | 81947 | Capacitor, .01 μ f, 500 WVDC |
| C6,7 | 88263 | Capacitor, .05 μ f, 600 V.DC |
| C8 | 39956 | Capacitor, .05 μ f, 1200 V.DC |
| DS1 | - | Xenon Bulb |
| M1 | 39976 | Elapsed Time Meter, 60 Hz. |
| - | 39974 | Elapsed Time Meter, 50 Hz. |
| M2 | 65142 | Ammeter, 0-150 A. |
| R1 | 82167 | Shunt, 150 A. 50 mV. |
| R2 | 39151 | Resistor, 150k Ohm, ½ Watt (Order 21-46059) |
| S1 | 80168 | Door Interlock Switch |
| S2 | 81275 | LAMP Switch, Rocker Type |
| S3 | 81276 | MODE Switch, Rocker Type |
| S4 | 78133 | Air Flow Switch, Exhaust |
| - | 81545 | Air Vane Actuator, Exhaust Switch |
| S5 | 72275 | VOLTAGE Switch, Pushbutton |
| S6 | 85109 | Air Flow Switch, Intake Blower |
| - | 39949A | Igniter Assembly, Gladiator |
| - | 40913 | Igniter Printed Circuit Board Assembly |
| - | 39939 | MS Connector & Interconnect Cable Assembly |
| - | 88318 | MS Connector, 14 Pin Male |
| * | 39933 | RF Suppressor Assembly (C1, C2, C3) |

PRINCIPLE OF IGNITER OPERATION

THE IGNITER is energized through the 115 V.AC control circuit when the LAMP “ON-OFF” switch (S2) is depressed and all interlocks and air flow switches are closed.

CAUTION: Do not use the Emergency Ignition switch (S102) in the igniter until it is determined that the polarity of the xenon bulb is correct. Use of the S102 switch bypasses the polarity sensing diode (CR201) on the igniter printed circuit board; if polarity is not correct, the bulb will be seriously damaged or destroyed. **No credit** is allowed on bulbs damaged by reversed polarity.

THE IGNITER supplies a high RF voltage pulse to the bulb, together with the high “No Load” DC voltage from the xenon power supply, to ignite the xenon bulb. After the arc is sustained, the AC circuit in the igniter is interrupted by the opening of K201 relay contacts on the signal of the timer circuit on the PC board. The DC output of the xenon power supply is automatically lowered to the power level required to maintain the arc. The DC power to the bulb is dependent upon the bulb characteristics and the setting of the output of the xenon power supply.

DC VOLTAGE is applied to the printed circuit board from the xenon power supply, energizing the 12 V.DC coil and closing the contacts of K201 relay, completing the AC circuit through the igniter to the T102 high voltage (10 kV.) transformer. High voltage boost capacitor C107 is charged to a voltage sufficient to cause breakdown across the E101 spark gap. Approximately 35 kV. is supplied to the xenon bulb for ignition.

S101 is the igniter cover interlock switch and S102 is the Emergency Ignition switch, which is a bypass for the K201 relay contacts and CR201 polarity sensing diode on the PC board. Components C101, 102, and 103 function as RF bypass capacitors on the igniter. The C108 capacitor serves as a coupling capacitor to the current coil.

THE PC BOARD operates on DC voltage from the xenon power supply. Capacitor C201 across the positive #10 and negative #15 is an RF suppression capacitor. Resistor R201 and zener diodes VR201 and 202 drop the DC voltage to 12 volts for the K201 relay coil. CR201 is the polarity sensing diode. C204 is a polarized capacitor used for arc suppression at the K201 relay coil, and CR202 functions as a transient protection diode.

THE FOLLOWING COMPONENTS are parts of the timing circuit on the PC board: Timer chip U201, resistors R202, 203, and the polarized capacitor C203. The C203 capacitor functions as the timing control, and CR203 serves as the “ON” time control diode. C202 is the control voltage isolation capacitor.

IGNITER ASSEMBLY, SCHEMATIC

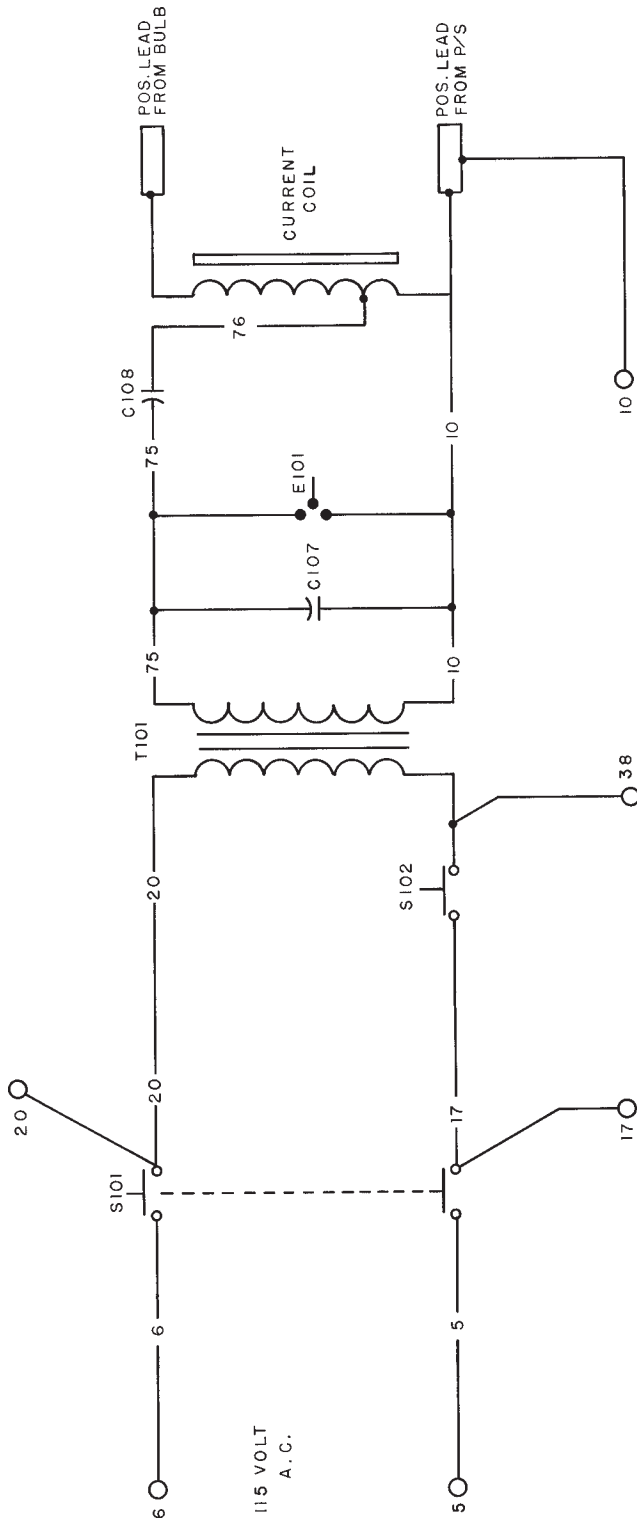

| Ref. | Desig. | Part No. | Description |
|------|--------|----------|------------------------------|
| | C107 | 39110 | Capacitor, 2400 pf, 20 kV/DC |
| | C108 | 39110 | Capacitor, 2400 pf, 20 kV/DC |
| | E101 | 39923 | Spark Gap Assembly |
| | S101 | 80168 | Cover Interlock Switch |
| | S102 | 80168 | Emergency Ignite Switch |
| | T101 | 39937 | High Voltage Transformer |
| | - | 39998 | Case & Coil, Potted Assembly |

IGNITER PRINTED CIRCUIT BOARD ASSEMBLY, SCHEMATIC

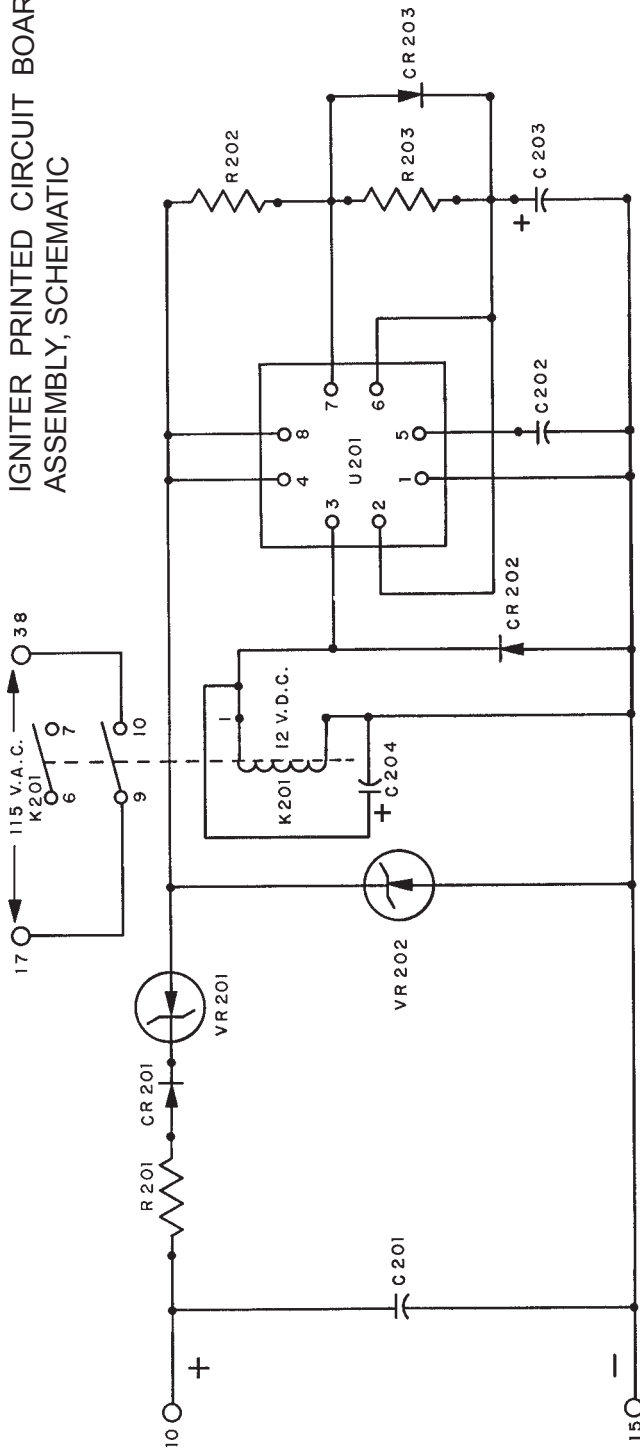

WIRE MARKERS
 A = 10
 B = 15
 C = 17
 D = 38

| Ref. | Desig. | Part No. | Description |
|-------|--------|----------|---|
| C201 | 88263 | 39159 | Capacitor, .05 μ f, 600 WVDC |
| C202 | 79127 | 72185 | Capacitor, .01 μ f, 600 WVDC |
| C203 | 39156 | 39164 | Capacitor, 15 μ f, 30/35 WVDC |
| C204 | 88249 | 39211 | Capacitor, .1 μ f, 600 WVDC |
| CR201 | 85112 | 39167 | Diode, 2.5 A. 1000 PRV |
| CR202 | 85112 | 39162 | Diode, 2.5 A. 1000 PRV |
| CR203 | 85112 | 39145 | Diode, 2.5 A. 1000 PRV |
| K201 | 39154 | 40913 | Relay, P&B R10-E1-W2S800 |
| - | 39160 | 39966 | Relay Socket |
| - | 39161 | | Relay Hold-Down Spring |
| R201 | 39157 | | Resistor, 1k Ohm, 12 Watt |
| R202 | 39158 | | Resistor, 100k Ohm, 1/2 Watt |
| Ref. | Desig. | Part No. | Description |
| R203 | | 39159 | Resistor, 200k Ohm, 1/2 Watt |
| U201 | | 72185 | Timer IC, Motorola MC11455P1 |
| - | | 39164 | IC Socket, (6) Pin |
| VR201 | | 39211 | Zener Diode, 1N5377A (40913*) |
| VR201 | | 39167 | Zener Diode, 1N5369A (39966*) |
| VR202 | | 39162 | Zener Diode, 1N4742 |
| - | | 39145 | PC Board (less Components) |
| * | | 40913 | PCB Assembly, Standard |
| * | | 39966 | PCB Assembly (Older Models using High Reactance Power Supply) |

Assembly Number written on Component Side of PCB.

TROUBLE CHART

NORMAL OPERATION

WHEN THE SWITCH in the main AC supply line to the xenon power supply is in the ON position, and the 30 A. circuit breaker on the switching power supply is ON, the POWER light on the xenon power supply will glow. The lamphouse and power supply blowers will start. NOTE: Early model Strong Switching Power Supply blowers may not start until the LAMP switch has been closed.

OPERATION OF THE LAMPHOUSE BLOWERS will close the (2) air flow interlock switches (intake and exhaust), and if the lamphouse door is closed and correctly secured, the control circuit to the LAMP switch will be completed.

THE MODE SWITCH, located on the lamphouse instrument panel, should be in the "MAN." (Manual) position. This enables ignition control from the instrument panel, and is the normal mode of spotlight operation.

WHEN THE **LAMP SWITCH** is placed in the ON position, the AC control circuit in the lamphouse will energize the power supply circuitry providing DC current to the igniter and bulb. If an early model Strong switching type power supply is used, the power supply blowers will start at this point.

THERE WILL BE a distinctly audible high voltage arc ping at the igniter arc gap and across the bulb electrodes. The bulb should ignite immediately after one or two of these high voltage pulses, and the lamp current will adjust to the output setting of the xenon power supply. Multiple ignition pulses prior to bulb ignition normally indicate a low DC output setting. See xenon power supply manual. A "warm" or aged xenon bulb might also require multiple strikes.

TROUBLE SHOOTING

IF THE XENON BULB does not ignite, observe the following operational sequences for assistance in locating and isolating the trouble area.

WHEN THE FAN(S) and the indicator light on the power supply are on, the AC circuit in the power supply is trouble free up to the terminal block in the power supply.

AT THIS TIME, the lamphouse blowers should operate. If this does not occur, the trouble is in the cover interlock switch, the access panel interlock switch, the blower motor, a loose connection, a broken #2 or #4 lead, or a blown F1 seal blower fuse. Check the 1.5 A. fuse in the in-line fuseholder. **CAUTION:** To prevent bulb ignition when checking the AC control circuit in the lamphouse, remove lead #10 from the igniter terminal strip.

CHECK AT THIS TIME for **115 V.AC Control Voltage** at the access door interlock switch (wires 2 & 4), and the blower terminals (9 & 12). The door interlock switch must be manually actuated to energize the blowers. Replace #10 lead before proceeding.

THE VANES on the air flow switches should raise. With the MODE switch in the “MAN.” position and the LAMP switch in the “ON” position, the running time meter should start and indicate elapsed time. If this meter does not operate, check for continuity at the MODE and LAMP switches.

A DEFECTIVE RUNNING TIME METER will *not* prevent bulb ignition.

WITH THE “LAMP” SWITCH in the “ON” position, a distinct high voltage arc ping should be heard at the spark gap in the igniter, and the flash of the xenon bulb should be visible through the ammeter as a high DC voltage pulse is applied across the bulb electrodes.

IF THE HIGH VOLTAGE PING or the flash at the ammeter is not apparent, check for 115 V.AC at terminals 5 & 6 at the terminal board. If 115 V.AC is present, and terminals are tight, check then the “**No Load**” DC Voltage between the lamphouse and power supply. Remove either lead #5 or #6 at the terminal board to prevent bulb ignition and defeat the door interlock switch. Check the DC voltage across terminals #10 (-) and #15 (+). A reading of 85 V.DC should be measured if using a high reactance power supply; 120-170 V.DC if using a switching type. If this voltage is not indicated, the problem is in the leads between the lamp-house and power supply, or in the power supply boost circuit. See the trouble shooting section of the power supply manual for additional instructions. Replace lead #5 or #6 at the igniter before proceeding.

THE SWITCHING-TYPE XENON POWER SUPPLY furnished with the spotlight system includes thermal overload switches and protection circuits to prevent damage resulting from high or low input voltage. Loss of DC open circuit voltage, or an interruption of DC sustaining current, may be traced to these circuits. See the power supply manual.

IGNITER PRINTED CIRCUIT BOARD 40913 is required for use with the switching type xenon power supply. If the lamphouse is equipped with an older type, replace it with the 40913 board. If the lamphouse ignites only by means of the emergency ignition switch, replace the igniter PC board.

IF THE HIGH VOLTAGE ARC is audible at the lamphouse and the bulb does *not* flash, check for a lamphouse DC lead arcing to ground. If no ground fault is detected, replace the bulb and attempt ignition with the new bulb.

IF THE HIGH VOLTAGE ARC is audible at the lamphouse, the flash of the bulb is visible in the ammeter, but ignition of the bulb is not sustained, the problem area is in the power supply. See the trouble shooting section of the power supply manual for additional instructions.

IF THE HIGH VOLTAGE ARC is *not* audible or the flash of the bulb visible, the problem is in the igniter or igniter PC board assembly.

EXCHANGE of components (i.e. igniters, printed circuit boards) between two similar Strong Xenon Gladiators to aid in diagnosis of a problem is encouraged. This will not lead to equipment damage, and will not void equipment warranty.

XENON GLADIATOR II TROUBLESHOOTING

Bulb fails to ignite.

1. MODE switch S3 set to "AUTO." Place in "MAN." position when not employing automated or remote lamphouse operation.
2. AC power not on to lamphouse. Turn switching power supply 30 A. circuit breaker ON. If 115 V.AC not read at 2 & 4, see power supply manual.
3. Door interlock switch (S1) open. Close and secure lamphouse door.
4. Faulty interlock switch(s). Check for 115 V.AC at 9 & 12; replace switch(s) if defective.
5. Air vane switches not closing. Check for unobstructed operation; clean if required. Check continuity between "NO" and "COM;" replace if defective.
6. Faulty S2 "ON-OFF" switch. Check for voltage at 3 & 5; check for loose terminals or wiring. Replace if defective.
7. Blower fuse F1 blown. Replace as required (1.5 A. Std.).
8. Low AC source voltage actuating "brownout" protection circuit in xenon power supply.

Bulb fails to ignite; ping audible, bulb flash visible.

1. Inadequate DC output from xenon power supply. Set power supply output to correct range required for bulb wattage (90 A. nominal for 2500 watt).
2. If bulb flash is visible but faint, check for defective HV capacitor(s) in igniter. Replace if defective.
3. Faulty or expired xenon bulb. Replace as required.

Bulb fails to ignite; ping audible, no bulb flash.

1. Faulty xenon bulb. Check for cracked electrodes or darkened envelope. Replace if defective.
2. Ignition pulse shorting to ground. Inspect DC leads for burned insulation; dress leads away from grounded metal components.

No high voltage ping audible; MODE switch in "MAN." and LAMP switch in "ON."

1. Loss of AC control voltage. Check xenon power supply for tripped circuit breaker or open thermal switch. See power supply manual.
2. Little or no DC "No Load" voltage. Measure DC "No Load" voltage at 10 & 15. See power supply manual.
3. Open fuse F1 (600 V.) on switching power supply. SEE POWER SUPPLY MANUAL. Allow (20) minutes for capacitor discharge before replacing.
4. Faulty igniter printed circuit board. If lamphouse ignites immediately when emergency ignition switch is pressed, replace printed circuit board.
5. Loose spark gap connections or terminals. Repair or replace as required.
7. Faulty igniter. Check for 115 V.AC at 5 & 6; adequate DC "No Load" at 10 & 15. If present, and igniter does not fire, replace igniter.

Bulb goes out during operation.

1. Xenon power supply overheated; thermal switch open. Check power supply blower(s), air inlets and outlets unobstructed. See power supply manual.
2. Xenon bulb depressurizing. Check for envelope discoloration; replace if defective.
3. Lamphouse blower not moving adequate air. Clean; lubricate seal blower.
4. Lamphouse blower failed or obstructed. Clean dust and dirt from blower inlet grille. Check for 115 V.AC at 7 & 8; replace blower if defective.
5. Lamphouse air vane switches faulty. Check for vane actuation; adjust or replace as required.
6. Lamphouse exhaust obstructed. Clear obstruction; clean outlet grille.
7. Exhaust air flow switch reacting to backdraft. Adjust actuator to compensate for backdraft.
8. Fluctuating AC source voltage actuating brownout or spike protection circuits in xenon power supply. See power supply manual.

Power supply does not energize when actuated.

1. Door interlock switch, B1 blower, F1 blower fuse, S4 air vane switch, S2 power switch, S3 MODE switch. Check for 115 V.AC at each station; replace defective component.

SEE POWER SUPPLY TROUBLESHOOTING UNDER SAME HEADING.

Noise in theatre sound as bulb ignites.

1. Faulty RF suppression capacitor(s). Remove and test C1, C2, C3, C4A or C4B. Replace if defective.
2. Lamphouse, power supply, or sound system not properly grounded. Connect to adequate earth ground.
3. Leads between lamphouse and automation contact not shielded. Shield leads in conduit. ("AUTO" Mode applications only.)

Excessive light flicker..

1. Faulty or aged bulb. Check for cracked or sagging electrodes; replace if defective.
2. Excessive ripple in DC output. See power supply manual.
3. Arc stabilization magnet reversed. NORTH pole should point toward operator's side. Check with compass if required.

Reduced light output.

1. Normal bulb aging. Increase output current. DO NOT EXCEED MAXIMUM CURRENT LEVEL SPECIFIED BY BULB MANUFACTURER.
2. Soiled reflector. Clean using commercial glass cleaner; USE NO ABRASIVES.
3. Soiled heat filter, projection lens, or large lens. Clean as required.

Extremely long duration between ignition pulses.

1. Low DC "no load" voltage from the xenon power supply. Check "no load" voltage; see power supply manual.
2. Defective spark gap. A "Ping" sound is normal; excessive "Hissing" is abnormal. Replace if defective.

Extremely long duration between ignition pulses (continued)

3. Low AC voltage to lamphouse. Check for 115 V.AC at 2 & 4; if below 95 volts, check stepdown transformer in xenon power supply. See power supply manual.
4. Defective timer IC chip on igniter PC board. Replace if defective.

Igniter continues to fire after bulb ignites.

1. Faulty igniter printed circuit board. Replace circuit board IMMEDIATELY to prevent bulb damage.

Color gels burning or fading prematurely.

1. Bulb focused to “hot spot.” Refocus bulb to flat field with iris fully open and spot size control handle (“trombone”) fully forward.
2. Heat filter glass reversed or peeled. Check for *coated surface toward bulb*; replace if coating peeled.
3. Reflector coating peeled. Replace if defective.

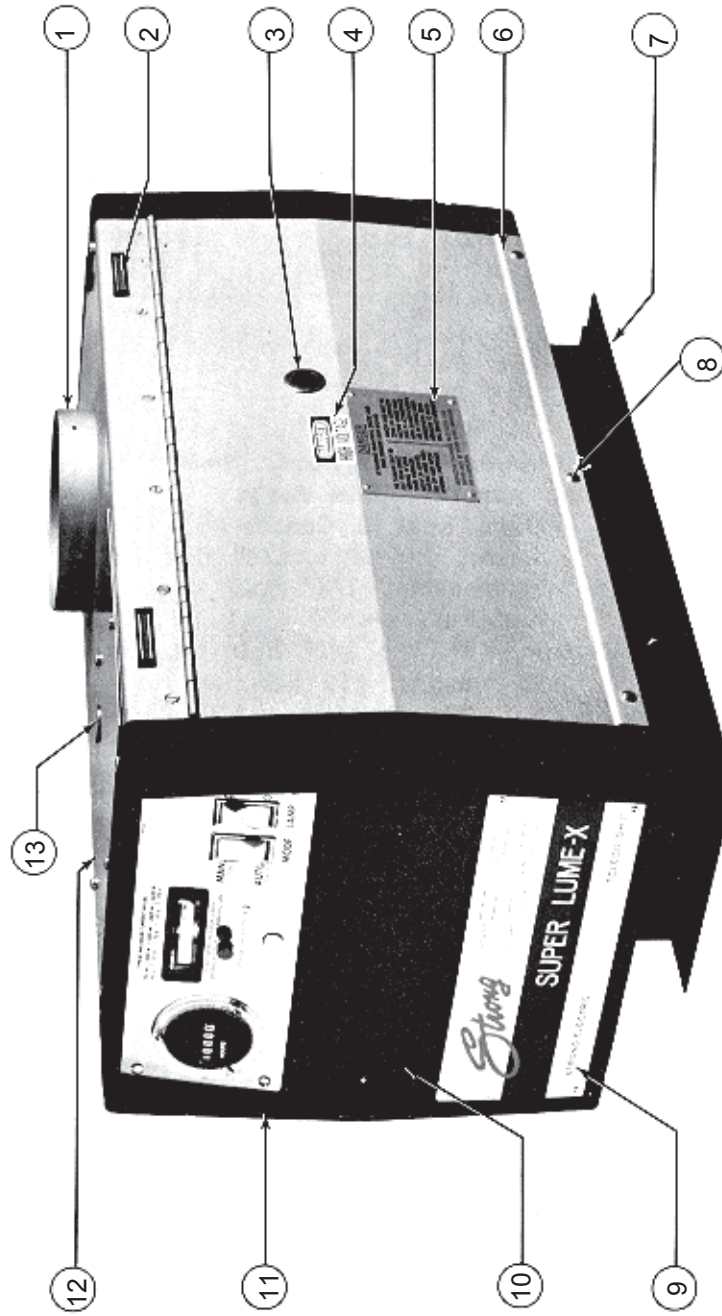

FIGURE 1

PARTS LIST

Figure 1

| <u>Item</u> | <u>Part No.</u> | <u>Description</u> |
|-------------|-----------------|---|
| 1 | 39964 | Top Cover & Door Welded Assembly |
| - | 4100371 | Screw, 10-32 x 3/8" Pan Head |
| - | 00885 | Lockwasher, #10 |
| 2 | 39139 | Magnetic Door Catch (2 req'd.) |
| 3 | 48930 | Arc Viewing Port |
| 4 | 65353 | DANGER Label |
| 5 | 81282 | CAUTION Label |
| - | 01639-5 | Pop Rivet, 1/8" |
| 6 | 39964 | Top Cover & Door Welded Assembly |
| 7 | 39995 | Base Adapter Assembly |
| - | 39125 | Base Plate |
| - | 39126 | Base Channel, Right |
| - | 39127 | Base Channel, Left |
| - | 39128 | Front Shim |
| - | 4110310 | Screw, 10-24 x 5/16" Flat Head |
| - | 39129 | Shim, Rear & Center |
| - | 4250623 | Screw, 1/4-20 x 5/8" Hex Head |
| - | 4257000 | Lockwasher, 1/4" Split Ring |
| 8 | 4100502 | Tamperproof Screw, 10-32 x 1/2" Holt Head |
| - | 4107101 | Flatwasher, #10 |
| - | 4108021 | Tinnerman Nut, #10 (Clip-On) |
| - | 65149A | Screwdriver (for 4100502) |
| 9 | 39219 | Name & Data Plate, Super Lume-X |
| - | 01639-2 | Pop Rivet, 1/8" |
| 10 | 65968 | Cover Assembly, Bulb Adjust Controls |
| - | 65140 | Cover Plate |
| - | 65166 | Plunger, Black Plastic |
| - | 65167 | Grommet, Black Plastic |
| 11 | 39954 | Back Casting Assembly (see Fig. 3 & 4) |
| 12 | 39982 | Igniter Access Panel |
| - | 4080310 | Screw, 8-32 x 5/16" Pan Head |
| - | 4087004 | Lockwasher, #8 |
| 13 | 57275 | Plug Button, Emergency Ignite Switch |

NOT SHOWN

| | |
|-------|---|
| 71284 | Cam Lock & Key, Lamphouse Access Door |
| 25372 | Cam Lock Security Screw, Special Hex Head |

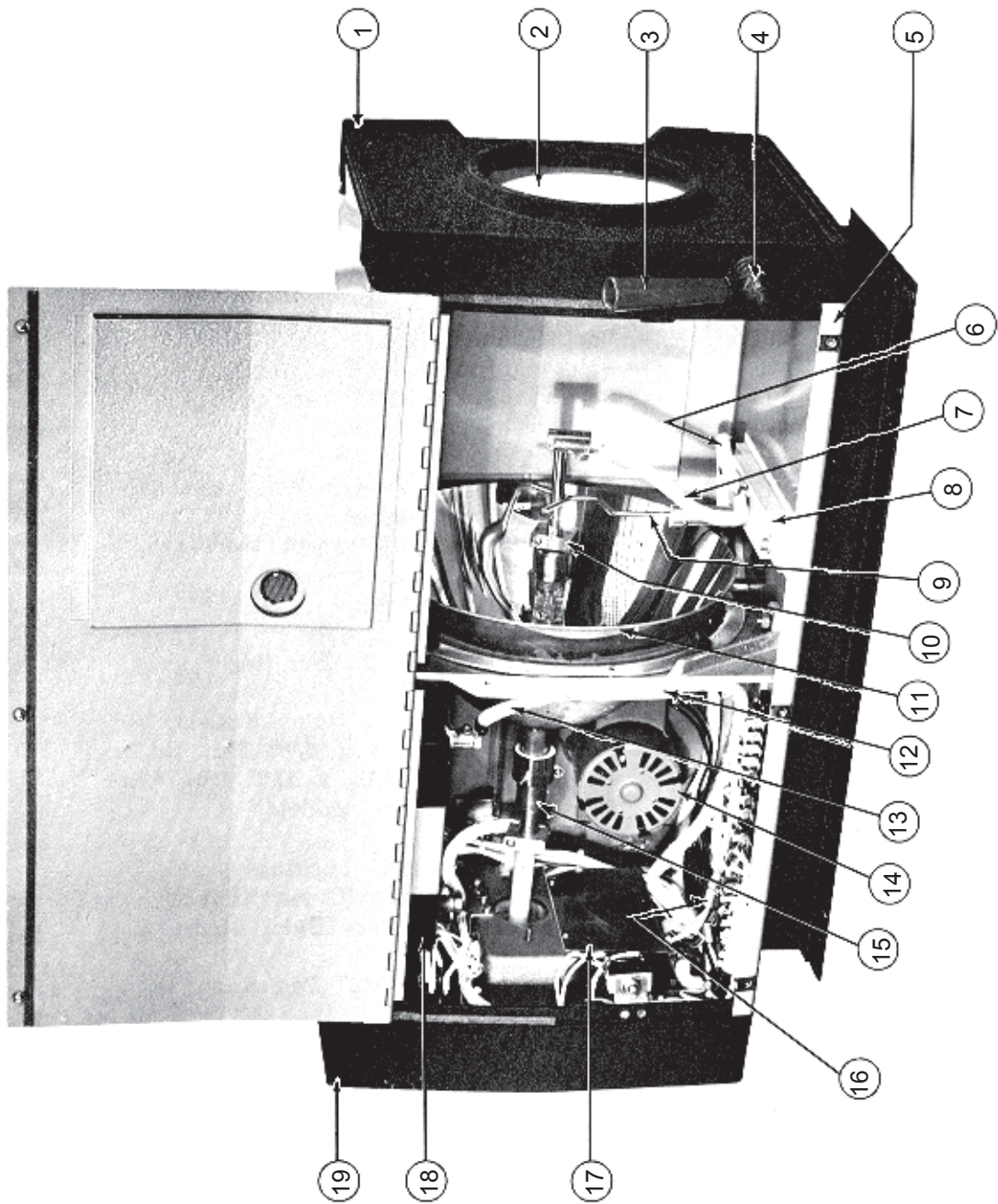

FIGURE 2

PARTS LIST

Figure 2

| <u>Item</u> | <u>Part No.</u> | <u>Description</u> |
|-------------|-----------------|---|
| 1 | 65111 | Front Casting |
| 2 | - | <i>Douser Assembly not used on</i> |
| 3 | - | <i>Gladiator Lamphouse</i> |
| 4 | 41-98034 | Hole Plug, 1/2" (not shown) |
| 5 | 39972 | Lamphouse Base Pan |
| - | 4100371 | Screw, 10-32 x 3/8" Pan Head |
| - | 4107001 | Lockwasher, #10 |
| - | 4108021 | Tinnerman Nut, #10 |
| 6 | 65948 | Lead Assembly, Shunt to Binding Post |
| 7 | 39953 | Negative Lead & Contact Assembly |
| - | 4250373 | Screw, 1/4-20 x 3/8" Hex Head |
| - | 4257001 | Lockwasher, 1/4" |
| 8 | 39931 | Block & Post Assembly, Front Bulb Support |
| - | 4250507 | Mounting Screw, 1/4-20 x 1" Hex Head Nylon |
| 9 | 39975 | Bulb Support Yoke |
| - | 01704 | Spring Pin, Height Adjust |
| - | 4080259 | Set Screw, 8-32 x 1/4" |
| 10 | - | Bulb Adapter <i>not required</i> in Gladiator Lamphouse |
| 11 | 39978 | Reflector Assembly, Potted Assembly (as shown) |
| 11 | 39876 | Flanged Reflector, 11" Dichroic (current production) |
| - | 65435 | Reflector Adapter Ring, Black Enamel (incl. with 39876) |
| - | 21-58001 | Compression Spring, Long |
| - | 18194 | Shoulder Bolt |
| - | P-3055 | Compression Spring, Short |
| - | 4250870 | Ring Mounting Screw, 1/4-20 x 7/8" Hex Head |
| 12 | 65114 | Reflector Bulkhead Casting |
| - | 4250752 | Mounting Screw, 1/4-20 x 3/4" Hex Head |
| - | 39149 | Tie Rod (to Front Casting) |
| - | 4258001 | Hexnut, 1/4-20 |
| - | 39179 | Arc Stabilization Magnet |
| - | 81137 | Magnet Clamp |
| - | 39178 | Mounting Plate, Magnet Clamp |
| 13 | 39939 | Cable Assembly, Lamphouse to Power Supply |
| - | 88318 | MS Connector, (14) Pin (not shown) |
| 14 | 39938 | Lamphouse Blower Assembly, 115 V.AC, 50/60 Hz. |
| - | 85109 | Air Vane Switch (S6), 60 Hz. |
| - | 39955 | Air Vane Switch (S6), 50 Hz. |
| - | 83131 | Blower Inlet Grille |

PARTS LIST, Figure 2 (continued)

| <u>Item</u> | <u>Part No.</u> | <u>Description</u> |
|-------------|-----------------|---|
| 15 | - | Bulb Adapter <i>not required</i> in Gladiator Lamphouse |
| - | 39194 | Anode Clamp, Gladiator II |
| 16 | 39933 | RF Suppression Capacitor Assembly (C1,C2,C3) |
| 17 | 39165 | Shield, Printed Circuit Board |
| - | 4080252 | Screw, 8-32 x 1/4" Socket Head |
| - | 4087000 | Lockwasher, #8 |
| 18 | 39949A | Igniter Assembly (see Figure 5) |
| 19 | 39954 | Back Casting Assembly (See Figures 3 & 4) |

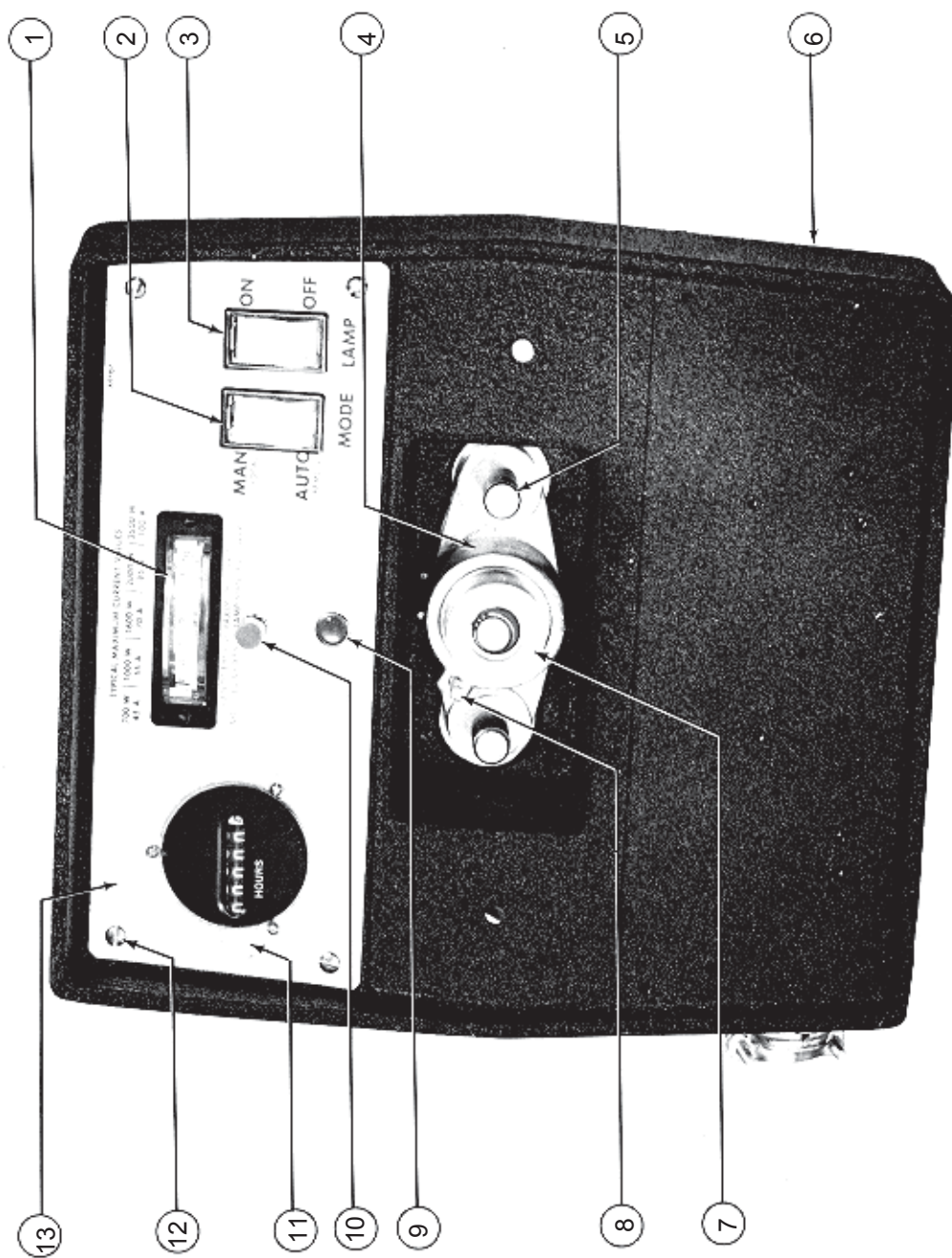

FIGURE 3

PARTS LIST

Figure 3

| <u>Item</u> | <u>Part No.</u> | <u>Description</u> |
|-------------|-----------------|--|
| 1 | 65142 | Ammeter (M2) |
| 2 | 81276 | MODE Switch (S3) |
| 3 | 81275 | LAMP Switch (S2) |
| 4 | 65116 | Casting, Bulb Adjust Mechanism |
| 5 | 37985 | Thumb Screw |
| - | 15010 | Compression Spring |
| - | 65150 | Fender Washer |
| 6 | 65112 | Rear Casting |
| 7 | 65959 | Focus Screw & Bearing Assembly |
| - | 21-48027 | Snap Ring, Bulb Collet |
| 8 | 65153 | Knurled Lockscrew |
| 9 | 41-98013 | Plug Button, 3/8" |
| 10 | 39970 | VOLTAGE Switch Assembly |
| - | 72275 | Switch, Pushbutton (S5) |
| - | 39151 | Resistor (R2) |
| - | 39152 | Label, "Press for Voltage" |
| 11 | 39976 | Elapsed Time Meter (M1), 60 Hz. |
| - | 39974 | Elapsed Time Meter, 50 Hz. (Export) |
| - | 4040500 | Mounting Screw, 4-40 x 1/2" Round Head |
| - | 4048003 | Hexnut, 4-40 |
| - | 4047001 | Lockwasher, #4 |
| 12 | 4080310 | Screw, 8-32 x 5/16" Pan Head |
| - | 4087004 | Lockwasher, #8 |
| 13 | 65107 | Instrument Panel (less Components) |

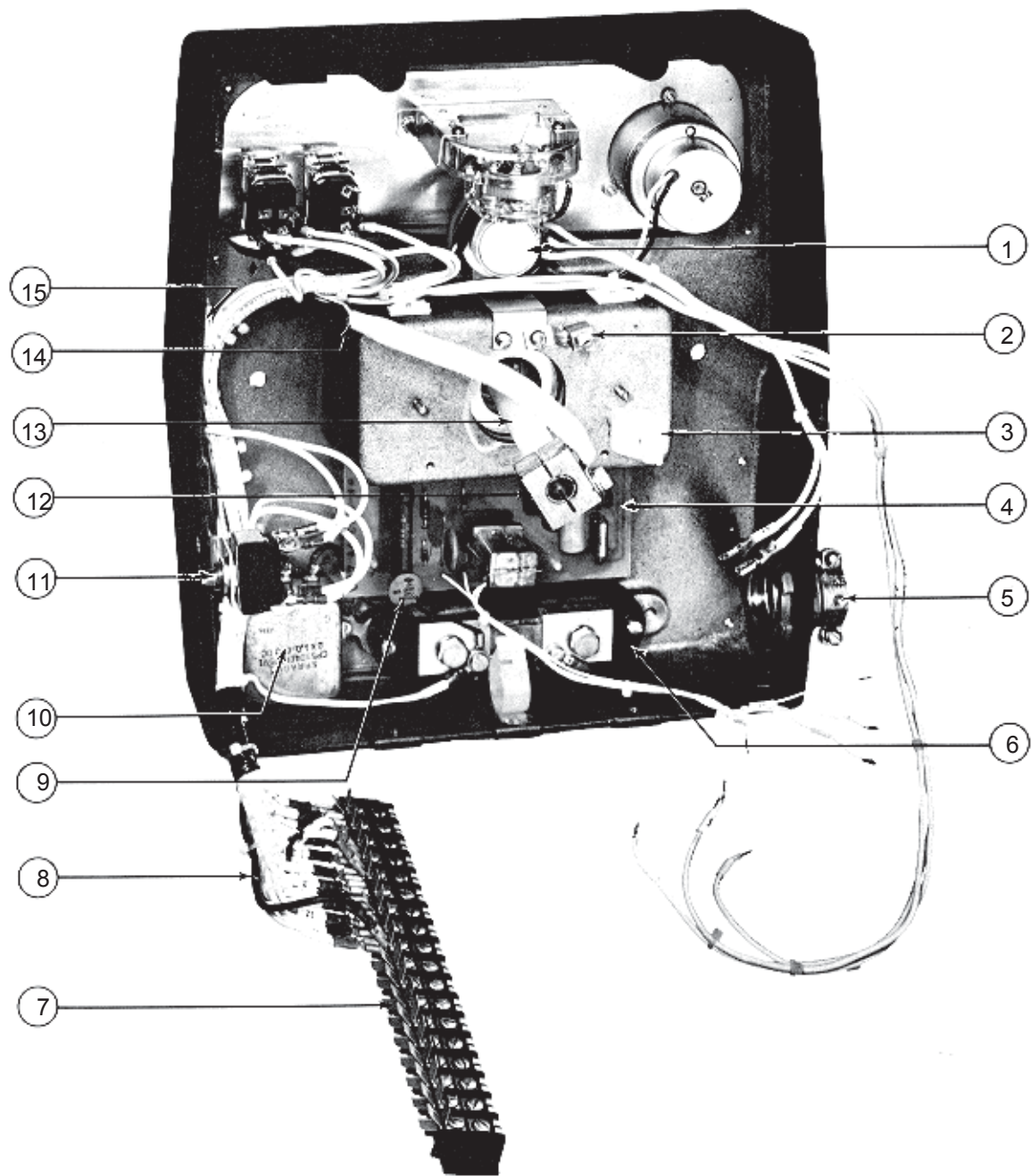

FIGURE 4

PARTS LIST

Figure 4

| <u>Item</u> | <u>Part No.</u> | <u>Description</u> |
|-------------|-----------------|---|
| 1 | 39969 | Potentiometer Assembly (early models*) |
| 2 | 79131 | Ground Lug |
| - | 4080311 | Screw, 8-32 x 5/16" Socket Head |
| - | 4087000 | Lockwasher, #8 |
| 3 | 39143 | Cable Clamp |
| 4 | 40913 | Igniter Printed Circuit Board |
| 4 | 39966 | Igniter Printed Circuit Board** |
| - | 39154 | Relay (K201) |
| - | 39155 | PCB Stand-Off, Nylon |
| 5 | 81143 | Strain Relief Cable Clamp |
| - | 39939 | Cable Assembly, Lamphouse to Power Supply |
| 6 | 82167 | Shunt (R1) |
| - | 4101004 | Mounting Screw, 10-32 x 1" Pan Head |
| - | 4107000 | Lockwasher, #10 Split Ring |
| 7 | 39130 | Barrier Strip, (15) Terminal |
| - | 39153 | Insulation & Marker Strip |
| 8 | 39921 | Wire Harness Assembly (incl. Item 7) |
| 9 | 81947 | Capacitor Assembly (C5) |
| - | 4110250 | Grounding Screw, 10-24 x 1/4" Socket Head |
| - | 4107000 | Lockwasher, #10 |
| 10 | 39986 | Capacitor Assembly |
| - | 80177 | Capacitor (C4A) |
| 11 | 80168 | Door Interlock Switch |
| - | 39622 | Bracket |
| - | 4060501 | Screw, 6-32 x 1/2" Flat Head |
| - | 4067001 | Lockwasher, #6 |
| - | 4098001 | Hexnut, 6-32 |
| 12 | 39194 | Anode (+) Clamp |
| - | 4080870 | Clamping Screw, 8-32 x 7/8" Socket Head |
| 13 | 39952 | Bulb Support Collet |
| 14 | 39945 | Igniter Cable & Clamp Assembly |
| - | 4250373 | Screw, 1/4-20 x 3/8" Hex Head |
| - | 4257000 | Lockwasher, 1/4" |
| 15 | 72199 | Wire Tie Mount, Self-Adhesive |
| | * | Used with Strong Type 88000 Power Supplies only |
| | ** | Used with High Reactance Power Supplies (pre-1989) only |

IGNITER ASSEMBLY

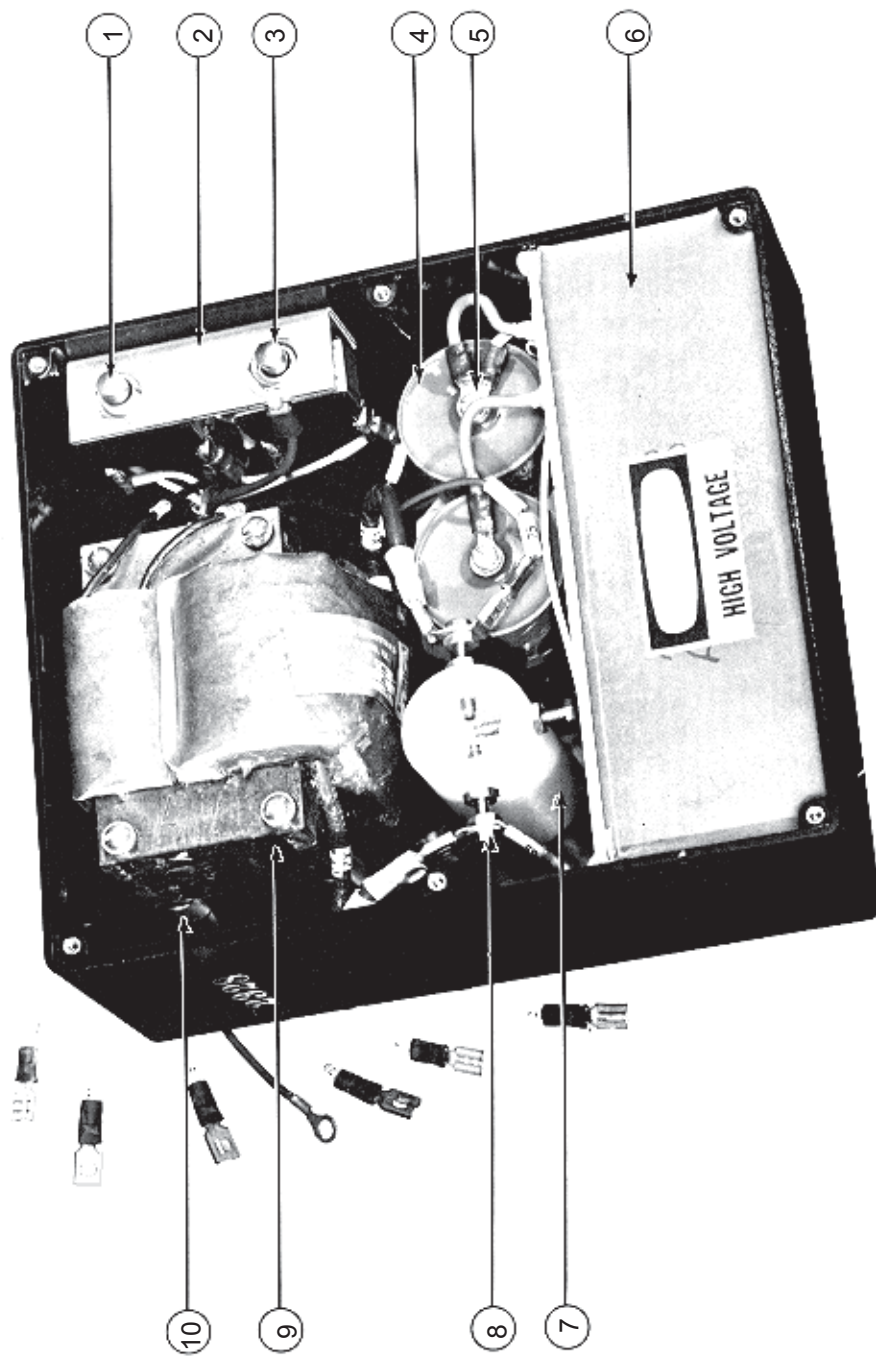

FIGURE 5

PARTS LIST

Figure 5

| <u>Item</u> | <u>Part No.</u> | <u>Description</u> |
|-------------|-----------------|--|
| 1 | 80168 | Cover Interlock Switch (S101) |
| 2 | 39113 | Switch Bracket |
| - | 4100251 | Screw, 10-32 x 1/2" Flat Head |
| 3 | 80168 | Emergency Ignite Switch (S102) |
| 4 | 39110 | High Voltage Capacitor (C107, 108) |
| - | 4080252 | Screw, 8-32 x 1/4" Socket Head |
| - | 4087001 | Lockwasher, #8 |
| - | 39112 | Capacitor Mounting Plate |
| - | 4251001 | Screw, 1/4-20 x 1" Hex Head Nylon |
| - | 4258015 | Hex Nut, 1/4-20 Nylon |
| 5 | 4080250 | Screw, 8-32 x 1/4" Pan Head |
| - | 4087001 | Lockwasher, #8 |
| 6 | 39998 | Case & Current Coil, Potted Assembly |
| - | 65353 | DANGER Label |
| 7 | 39201 * | Spark Gap Body, Nylon |
| - | 4110501 | Screw, 10-24 x 1/2" Pan Head |
| 8 | 39107 * | Contact Screw, Tungsten |
| - | 39109 | Terminal Tab |
| - | 4107100 | Flatwasher, #10 Brass |
| - | 4088001 | Hexnut, 8-32 |
| * | 39923 | Spark Gap Assembly (Items 7 & 8, Gapped) |
| 9 | 39937 | High Voltage Transformer (T102) |
| - | 4087101 | Flatwasher, #8 |
| - | 4088001 | Hexnut, 8-32 |
| 10 | 39204 | Transformer Spacer |

NOT SHOWN

| | |
|---------|--|
| 39101 | Cover, Igniter Box |
| 4060250 | Cover Mounting Screw, 6-32 x 1/4" Pan Head |

LAMPHOUSE EXHAUST BLOWER
 Assembly No. 47935

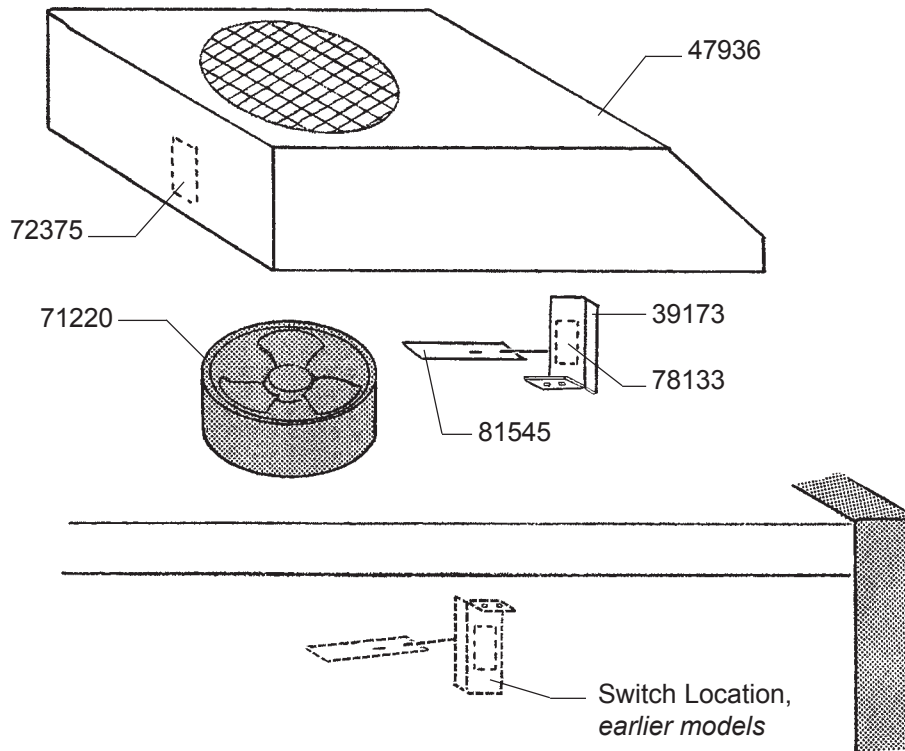

| <u>Part No.</u> | <u>Description</u> |
|-----------------|----------------------------------|
| 39173 | Switch Bracket |
| 47936 | Blower Housing, Welded Assembly |
| 71220 | Blower (B2), 115 V.AC, 50/60 Hz. |
| 40937 | Plug & Cord Assembly |
| 72375 | Barrier Strip, (2) Terminal |
| 78133 | Air Flow Switch (S4) |
| 81545 | Actuator, Air Flow Switch |

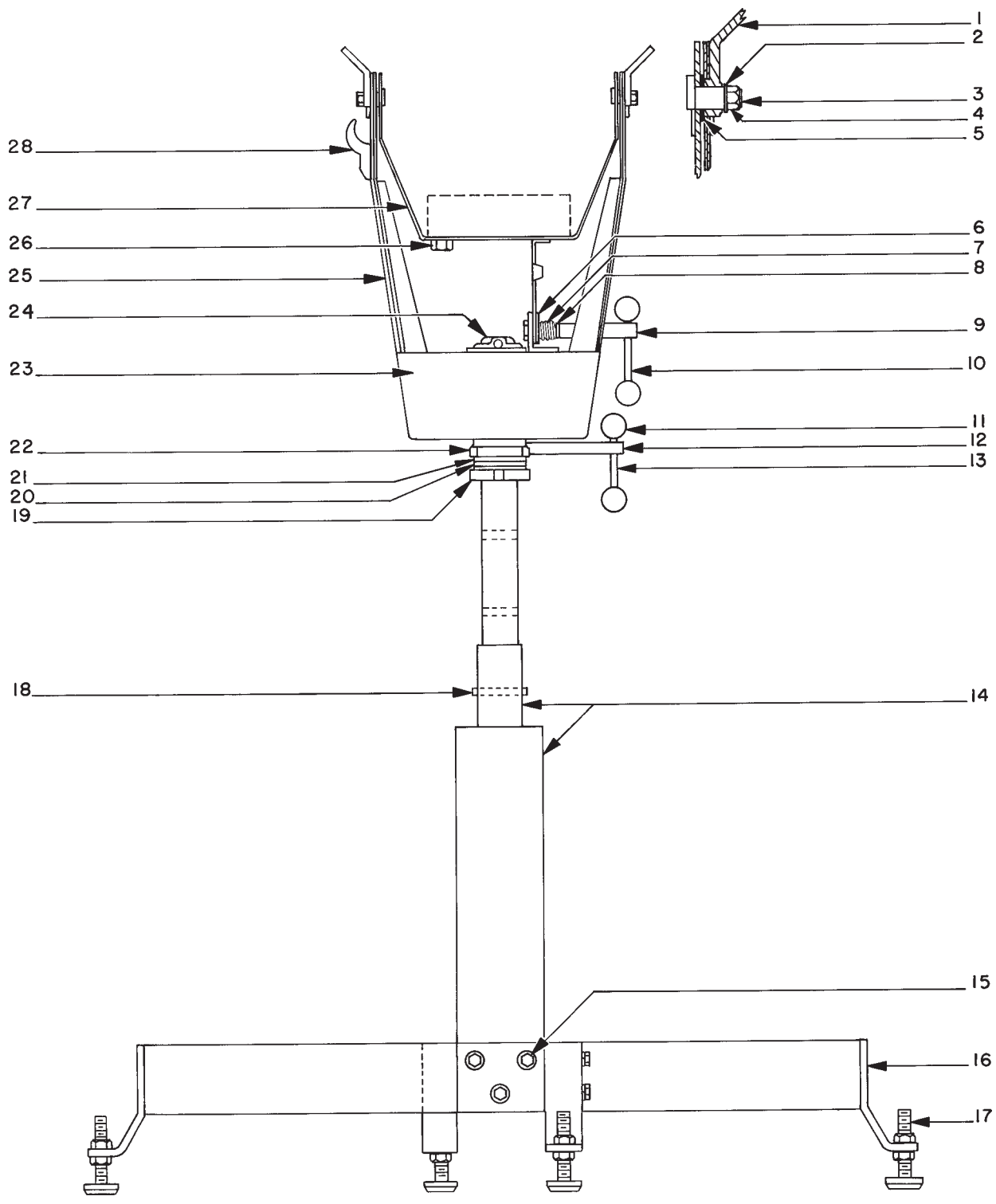

FIGURE 6

PARTS LIST

Figure 6

| <u>Item</u> | <u>Part No.</u> | <u>Description</u> |
|-------------|-----------------|------------------------------------|
| 1 | 49943 | Lifting Strap |
| 2 | 4377102 | Flatwasher, 3/8" |
| 3 | 49120 | Tilt Axis Bolt |
| 4 | 4378002 | Locknut, 3/8-16 Hex |
| 5 | 02411 | Washer, .640" I.D. x 1-1/4" O.D. |
| 6 | 49126 | Clamp Plate |
| 7 | 49125 | Compression Spring, Tilt Clamp |
| 8 | 49124 | Spring Bushing |
| 9 | 49223 | Clamp Shaft |
| 10 | 49130 | Clamp Handle |
| 11 | 10048A | Knob, Round Plastic |
| 12 | 49290 | Swivel Clamp Shaft |
| - | 49291 | Stop Plate, Horizontal Swivel |
| - | 4372500 | Bolt, 3/8-16 x 2-1/2" Square Head |
| 13 | 49130 | Clamp Handle |
| 14 | 83799 | Base Column, Welded Assembly |
| 15 | 83297 | Mounting Bolt, Base Leg |
| - | 4377001 | Lockwasher, 3/8" Split Ring |
| 16 | 83797 | Base Leg, Welded Assembly |
| - | 47238 | Tandem Caster, Locking (not shown) |
| 17 | 49226 | Leveling Foot |
| - | 4508001 | Locknut, 1/2-13 Hex |
| 18 | 83294A | Height Adjustment Pin |
| 19 | 83794 | Tube & Collar Assembly |
| 20 | 83113 | Needle Bearing |
| 21 | 83114 | Race, Needle Bearing |
| 22 | 49213 | Swivel Clamp Collar |
| - | 4250503 | Screw, 1/4-20 x 1/2" Hex Head |
| - | 4257000 | Lockwasher, 1/4" Split Ring |
| 23 | 83357 | Yoke Cover Plate |
| - | 4080375 | Screw, 8-32 x 3/8" Pan Head |
| - | 4087001 | Lockwasher, #8 |
| 24 | 83112 | Collar, Inner Tube |
| - | 4260370 | Set Screw, 1/4-28 x 3/8" Dog Point |
| 25 | 47951 | Yoke Assembly |
| 26 | 4371120 | Screw, 3/8-16 x 1" |
| - | 4377001 | Lockwasher, 3/8" |
| - | 4377103 | Flatwasher, 3/8" |
| - | 4378001 | Hexnut, 3/8-16 |
| 27 | 47958 | Saddle & Quadrant Assembly |
| 28 | 83341 | Cable Clamp |
| - | 4250623 | Screw, 1/4-20 x 5/8" Hex Head |

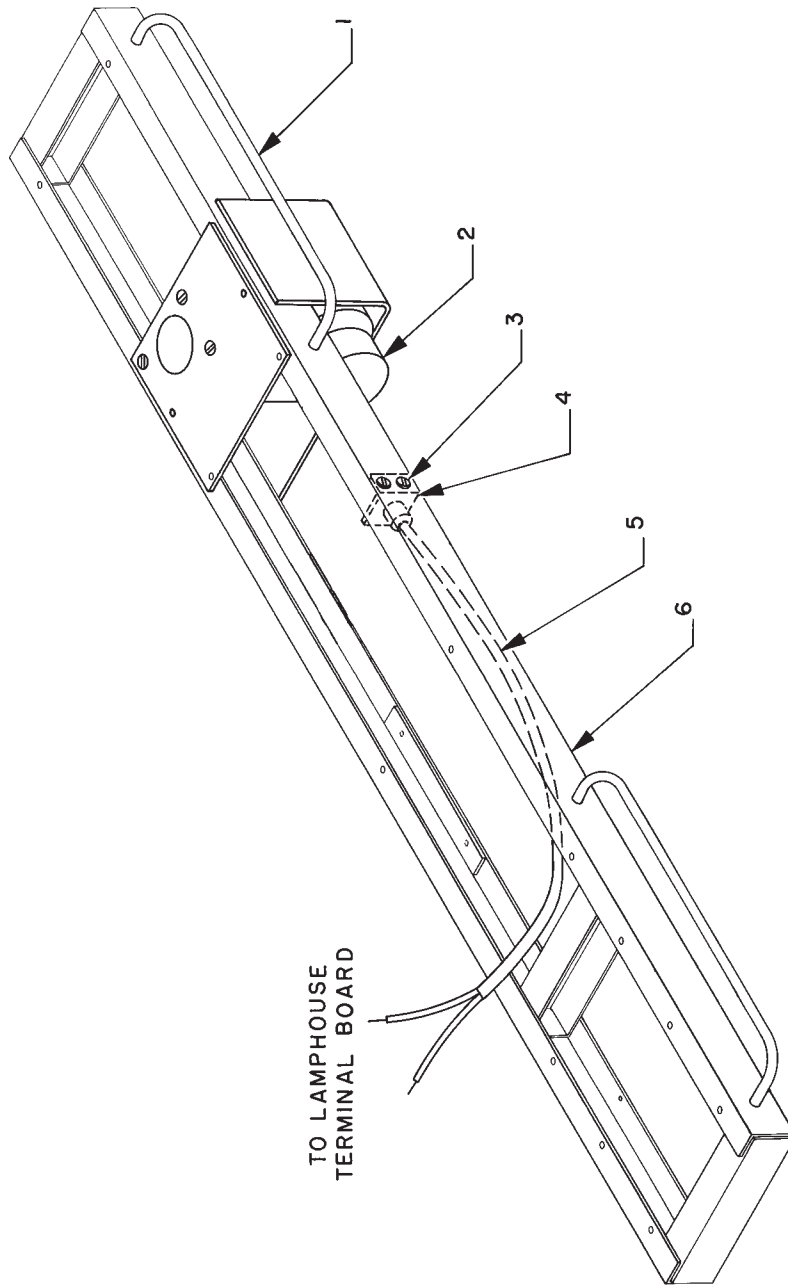

FIGURE 7

PARTS LIST

Figure 7

| <u>Item</u> | <u>Part No.</u> | <u>Description</u> |
|-------------|-----------------|--|
| 1 | 49342 | Hand Rail |
| - | 4317000 | Lockwasher, 5/16" Split Ring |
| - | 4310500 | Screw, 5/16-18 x 1/2" Hex Head |
| 2 | 47944 | Blower Assembly (B3), with Item 5 |
| - | 44191 | Blower Motor & Squirrelcage, 115 V.AC |
| - | 21-40011 | Plug, (2) Pin Male |
| - | 31-62007 | Molex Pin, Male |
| - | 21-40019 | Receptacle, (2) Pin Female |
| - | 31-62006 | Molex Pin, Female |
| 3 | 4080375 | Screw, 8-32 x 3/8" Pan Head (as req'd.) |
| 4 | 47177 | Receptacle Bracket (not req'd. in current units) |
| 5 | 21-71066 | Cable, 18/2 Type SJ (incl. with Item 2) |
| 6 | 47965 | Base Rail, Welded Assembly |

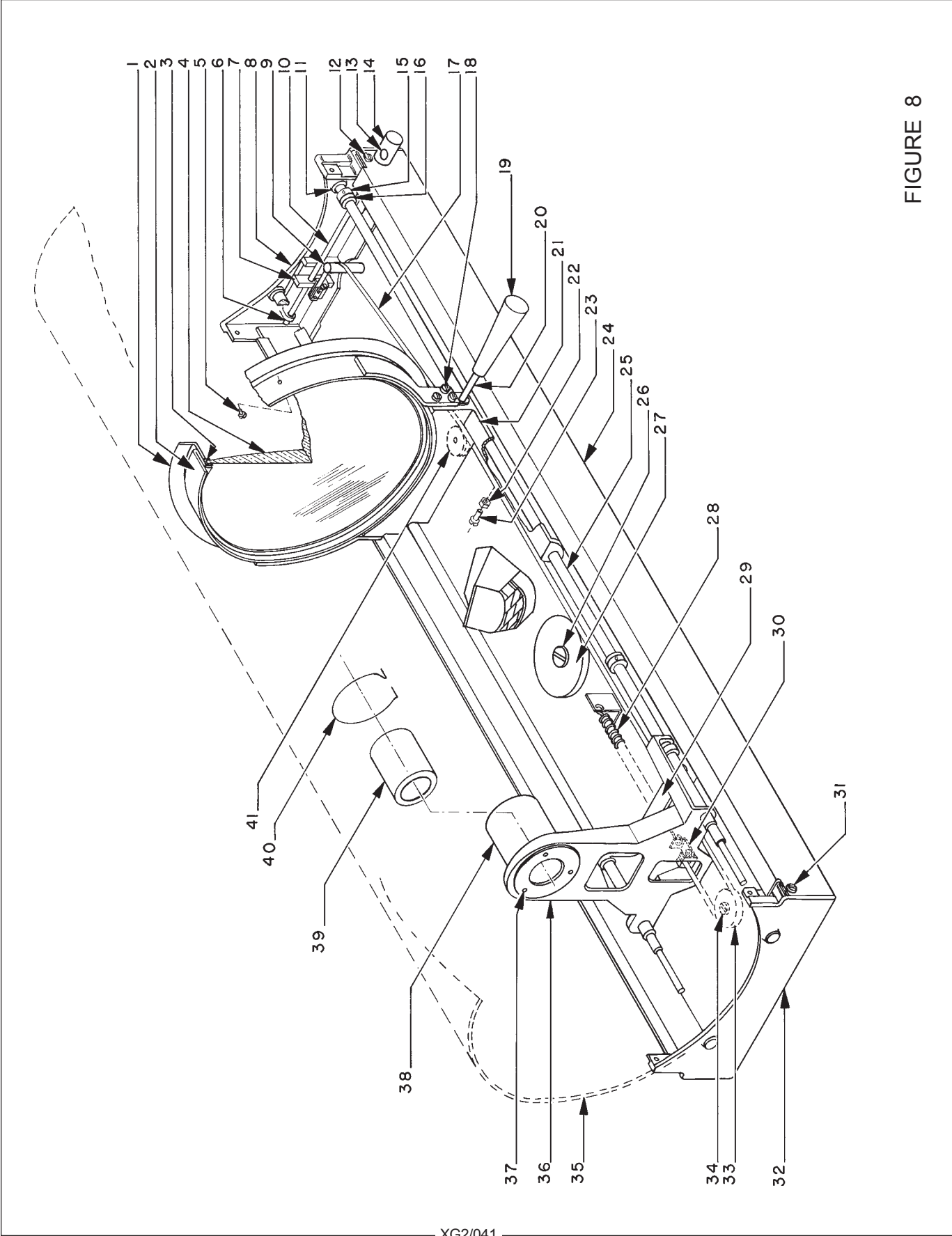

FIGURE 8

PARTS LIST

Figure 8

| <u>Item</u> | <u>Part No.</u> | <u>Description</u> |
|-------------|-----------------|--|
| 1 | 51417 | Large Lens Retainer |
| 2 | 51914 | Lens Ring, Welded Assembly |
| 3 | 51418 | Rubber Gasket, Lens Mount |
| 4 | 51408 | Large Lens, 11" Diameter |
| 5 | 4080250 | Screw, 8-32 x 1/4" Pan Head |
| 6 | 00919 | Cotter Pin, 1/16" x 1/2" |
| - | 4107100 | Flatwasher, #10 Brass |
| 7 | 51133 | Adjusting Block, Lens Focus |
| - | 4060253 | Screw, 6-32 x 1/4" Socket Head |
| - | 4067001 | Lockwasher, #6 |
| 8 | 51352 | End Casting, Front |
| 9 | 47207 | Stud, Lens Focus Adjust |
| - | 4250508 | Screw, 1/4-20 x 1/2" Pan Head |
| - | 4257004 | Lockwasher, 1/4" |
| 10 | 51454 | Adjusting Screw, Lens Focus |
| 11 | 48127 | Retaining Ring |
| 12 | 4250508 | Screw, 1/4-20 x 1/2" Pan Head |
| - | 4257004 | Lockwasher, 1/4" |
| 13 | 4080120 | Set Screw, Focus Adjust Knob |
| 14 | 51168 | Focus Adjust Knob |
| 15 | 51114 | Stop Collar, Slide Rod |
| - | 4100180 | Set Screw, 10-32 x 3/16" |
| 16 | 51479 | Rubber Bumper |
| 17 | 51910 | Ribbon Assembly, Lens Focus |
| 18 | 4110371 | Screw, 10-24 x 3/8" Socket Head |
| - | 4107000 | Lockwasher, #10 Split Ring |
| 19 | 51509 | Handle, Red Plastic |
| 20 | 51441 | Handle Shaft |
| - | 21-48011 | Retaining Ring |
| 21 | 51350 | Support Casting, Large Lens Carriage |
| 22 | 4258015 | Locknut, 1/4-20 Hex Nylon |
| 23 | 4251001 | Friction Brake Screw, 1/4-20 x 1" Hex Head Nylon |
| 24 | 47968 | Base Pan, Welded Assembly |
| 25 | 51453 | Slide Rod (Left & Right) |
| 26 | 51160 | Pulley Stud |
| - | 4087100 | Flatwasher, #8 Brass |
| 27 | 47210 | Large Pulley |

PARTS LIST, Figure 8 (continued)

| <u>Item</u> | <u>Part No.</u> | <u>Description</u> |
|-------------|-----------------|---|
| 28 | 51162 | Expansion Spring, Ribbon Tension |
| 29 | 51354 | Support Bracket, Slide Rods |
| - | 4250508 | Screw, 1/4-20 x 1/2" Pan Head |
| - | 4257004 | Lockwasher, 1/4" |
| 30 | 51120 | Retaining Clip, Spring & Ribbon |
| - | 4080310 | Screw, 8-32 x 5/16" Pan Head |
| - | 4087004 | Lockwasher, #8 |
| - | 00919 | Cotter Pin, 1/16" x 1/2" |
| 31 | 4250508 | Screw, 1/4-20 x 1/2" Pan Head |
| - | 4257004 | Lockwasher, 1/4" |
| 32 | 51353 | End Casting, Rear |
| 33 | 83163 | Small Pulley |
| 34 | 51160 | Pulley Stud |
| - | 4087100 | Flatwasher, #8 Brass |
| 35 | 47967 | Lens Mechanism Housing, Welded Assembly |
| - | 23059A | STRONG Insignia |
| - | 47168 | GLADIATOR Insignia |
| - | 45237 | Insignia, Roman Numeral "II" |
| - | 47962 | Rubber Light Baffle, for Item 20 Shaft |
| 36 | 83160 | Support Casting, Projection Lens |
| 37 | 4080372 | Screw, 8-32 x 3/8" Flat Head |
| 38 | 83144 | Mounting Tube, Projection Lens |
| 39 | 44239A | Projection Lens, Compound (Buhl), before March 2004 |
| 39 | 44239C | Projection Lens, Compound (ISCO), after March 2004 |
| 40 | 83155 | Retaining Ring, Projection Lens |
| 41 | 47211 | Pulley, Large Lens Carriage |

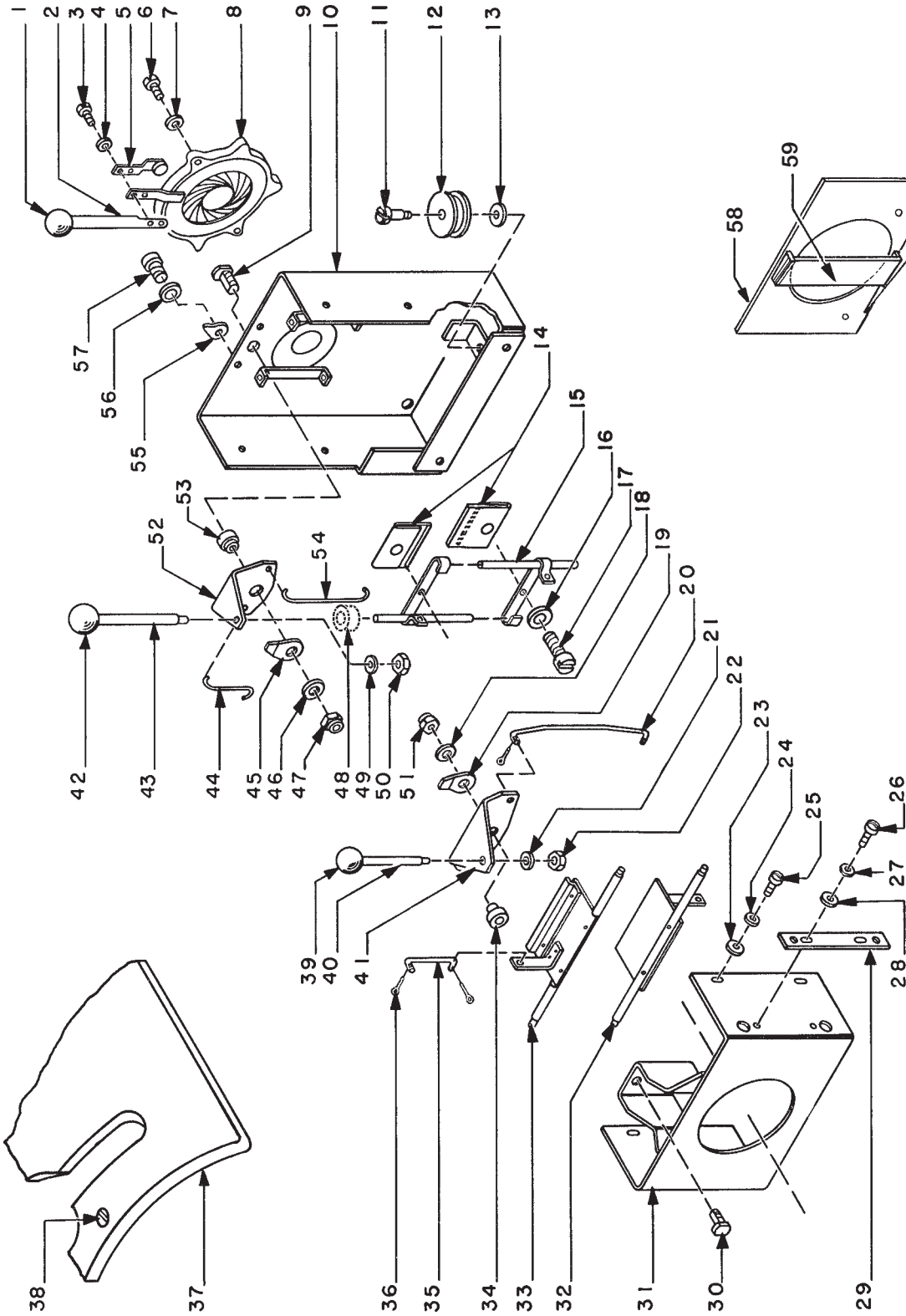

Item 58 Bracket mounts to back surface of Item 31.

FIGURE 9

PARTS LIST

Figure 9

| <u>Item</u> | <u>Part No.</u> | <u>Description</u> |
|-------------|-----------------|--|
| 1 | 10048A | Knob, Red Plastic |
| 2 | 51451 | Iris Shaft |
| 3 | 406037B | Screw, 6-32 x 3/8" Pan Head |
| 4 | 4067001 | Lockwasher, #6 |
| 5 | 51978 | Friction Spring & Button |
| - | 51229 | Friction Pad |
| 6 | 4060621 | Screw, 6-32 x 5/8" Socket Head |
| 7 | 4067001 | Lockwasher, #6 |
| 8 | 51979 | Iris (as shown; see Fig. 9A for current configuration) |
| - | 83181 | Plate, 51979 Iris |
| - | 83182 | Retaining Clip, 51979 Iris |
| 9 | 51226 | Pivot Stud |
| 10 | 83773 | Aperture Support Plate |
| 11 | 51160 | Pulley Stud |
| 12 | 83163 | Large Pulley |
| 13 | 4087100 | Flatwasher, #8 Brass |
| 14 | 47191 | Masking Blade |
| 15 | 47982 | Slide Assembly, Masking Blade |
| 16 | 4087000 | Lockwasher, #8 Split Ring |
| 17 | 4080375 | Screw, 8-32 x 3/16" Pan Head |
| 18 | 4257102 | Flatwasher, 1/4" |
| 19 | 51156 | Friction Plate (Replace with 4507106 Friction Washer) |
| 20 | 83134 | Fadeout Pull Rod, Long |
| 21 | 4257000 | Lockwasher, 1/4" Split Ring |
| 22 | 4258001 | Hexnut, 1/4-20 |
| 23 | 4107100 | Flatwasher, #10 Brass |
| 24 | 4107001 | Lockwasher, #10 |
| 25 | 4080250 | Screw, 10-32 x 1/4" Pan Head |
| 26 | 4080250 | Screw, 10-32 x 1/4" Pan Head |
| 27 | 4107001 | Lockwasher, #10 |
| 28 | 4107100 | Flatwasher, #10 Brass |
| 29 | 83351 | Retaining Strip, Fadeout Bracket |
| 30 | 51226 | Pivot Stud |
| 31 | 83890 | Fadeout Support Assembly |
| 32 | 83892 | Fadeout Blade, Lower |
| 33 | 83891 | Fadeout Blade, Upper |
| 34 | 51153 | Spacer Bushing |

PARTS LIST, Figure 9 (continued)

| <u>Item</u> | <u>Part No.</u> | <u>Description</u> |
|-------------|-----------------|---|
| 35 | 83133 | Fadeout Pull Rod, Short |
| 36 | 01704 | Spring Pin |
| 37 | 51357 | Cover Plate Casting |
| 38 | 4250508 | Screw, 1/4-20 x 1/2" Pan Head |
| 39 | 10048A | Knob, Red Plastic |
| 40 | 51155 | Control Lever, Fadeout Mechanism |
| 41 | 83143 | Fadeout Lever Bracket |
| 42 | 10048A | Knob, Red Plastic |
| 43 | 51452 | Control Lever, Masking Blades |
| 44 | 51498 | Masking Blade Pull Rod, Short |
| 45 | 51156 | Friction Plate (Replace with 4507106 Friction Washer) |
| 46 | 4317100 | Flatwasher, 5/16" |
| 47 | 4318004 | Hexnut, 5/16-18 FlexLock |
| 48 | MAL-64 | Spacer (early models only) |
| 49 | 4257000 | Lockwasher, 1/4" Split Ring |
| - | 4257102 | Flatwasher, 1/4" |
| 50 | 4258001 | Hexnut, 1/4-20 |
| 51 | 4318004 | Hexnut, 5/16-18 FlexLock |
| 52 | 48406 | Bracket, Masking Blade Control Lever |
| 53 | 51153 | Spacer Bushing |
| 54 | 51497 | Masking Blade Pull Rod, Long |
| 55 | 47170 | Stop Bracket, Iris Lever |
| 56 | 4087004 | Lockwasher, #8 Split Ring |
| 57 | 4080250 | Screw, 8-32 x 1/4" Pan Head |
| 58 | 47966 | Mounting Bracket, Heat Filter Glass |
| - | 4100371 | Mounting Screw, 10-32 x 3/8" Pan Head |
| - | 4107104 | Lockwasher, #10 |
| 59 | 65122A | Heat Filter Glass, Coated |

ASSEMBLIES

| | |
|-------|--|
| 83788 | Aperture Plate, Masking Blades, and Iris (Items 1-17, 42-50, & 52-57) |
| 83790 | Fadeout Mechanism and Blades (Items 18-36, 39-41, & 51) |

FIGURE 9A

| Part No. | Description |
|----------|-------------------------|
| 21-70029 | Spring Washer |
| 24369 | Bell Crank |
| 24372 | Adapter Ring |
| 24374 | Iris |
| 25017 | Bushing (with 41-51530) |
| 25034 | Iris Clamp |
| 4040310 | Screw, 4-40 x 5/16" |
| 406037B | Screw, 6-32 x 3/8" |
| 4080621 | Screw, 8-32 x 5/8" |
| 41-51530 | Shoulder Bolt |
| 51451 | Iris Control Handle |
| 81432 | Shoulder Screw |
| 72-00075 | Link |

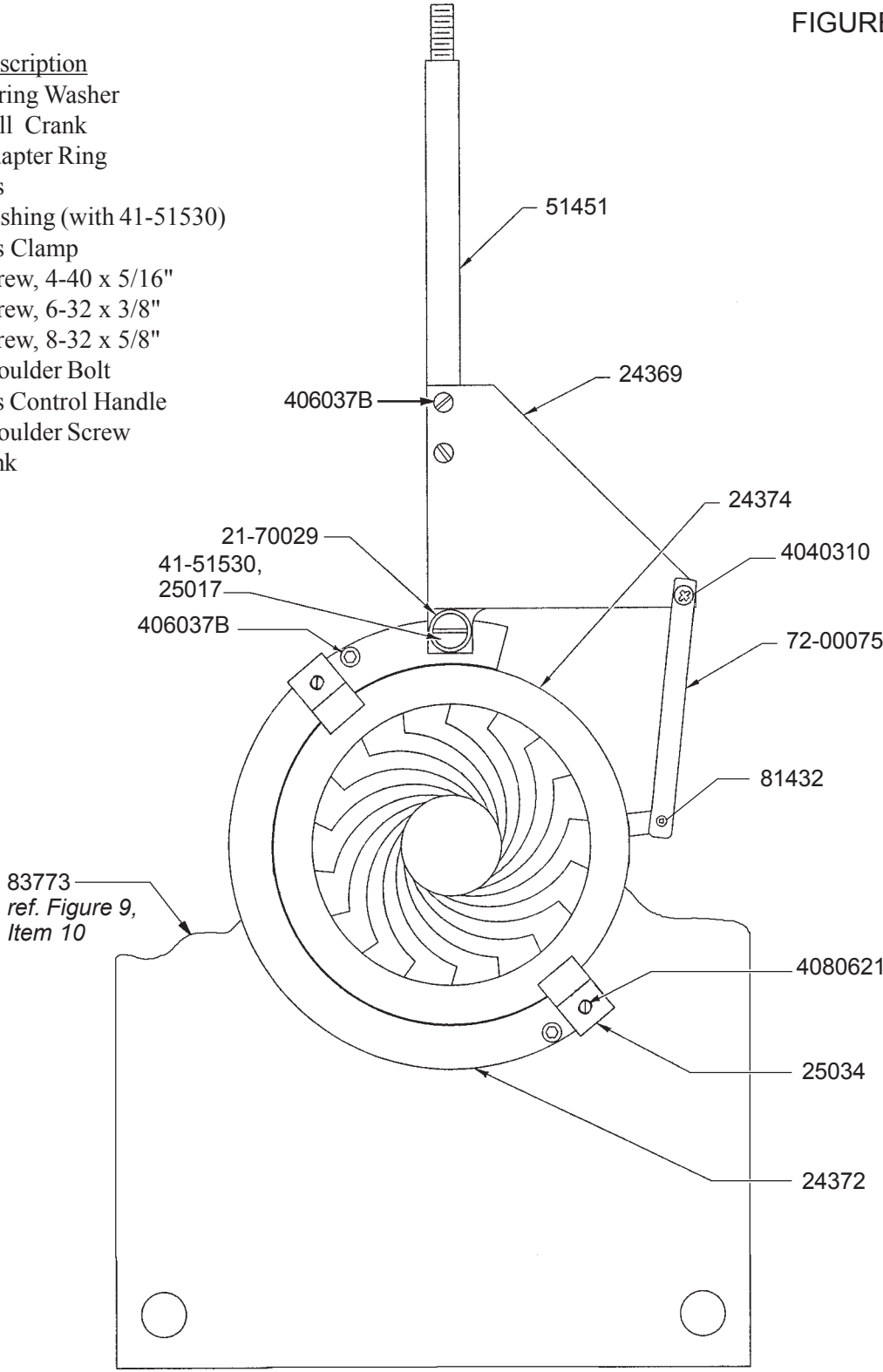

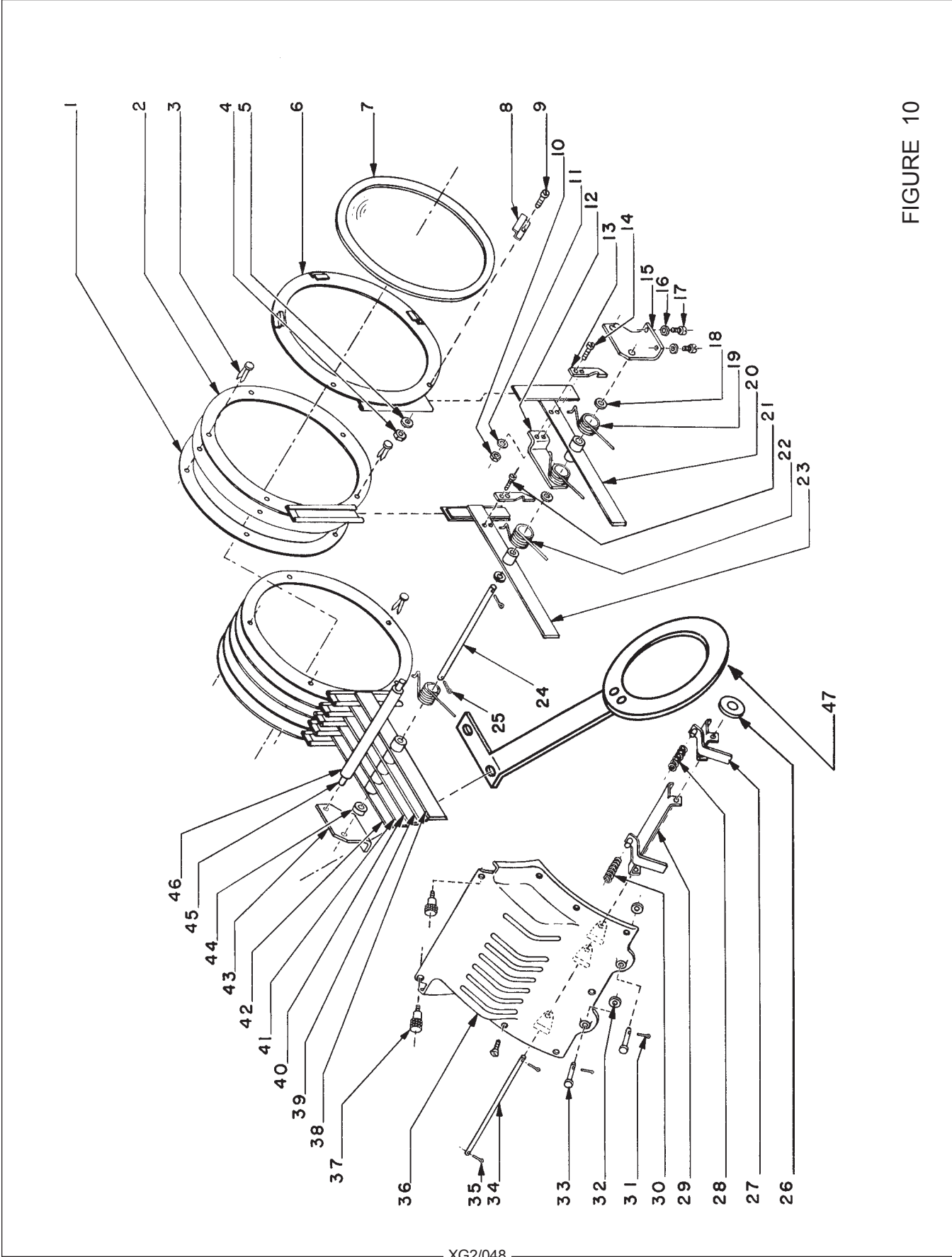

FIGURE 10

PARTS LIST

Figure 10

| <u>Item</u> | <u>Part No.</u> | <u>Description</u> |
|-------------|-----------------|-------------------------------------|
| 1 | 51376 | Cover Plate, Gel Frame |
| 2 | 51928 | Gel Frame & Slide Channel |
| 3 | 01456 | Paper Fastener |
| 4 | 4068001 | Hexnut, 6-32 |
| 5 | 4067001 | Lockwasher, #6 |
| 6 | 51926 | Plate & Slide Channel, Ultra Violet |
| 7 | 51192 | Ultra Violet Lens |
| 8 | 51406 | Clip, UV Lens |
| 9 | 406037B | Screw, 6-32 x 3/8" Pan Head |
| 10 | 4088001 | Hexnut, 8-32 |
| 11 | 4087000 | Lockwasher, #8 Split Ring |
| 12 | 51404 | Support Arm |
| 13 | 51396 | Catch, Color Arm |
| 14 | 4080754 | Screw, 8-32 x 3/4" Pan Head |
| 15 | 51379 | Mounting Bracket, Right |
| 16 | 4107000 | Lockwasher, #10 Split Ring |
| 17 | 4110501 | Screw, 10-24 x 1/2" Pan Head |
| 18 | 51398 | Nylon Washer |
| 19 | 51402 | Torsion Spring, UV Filter |
| 20 | 51927 | UV Arm Assembly |
| 21 | 408037A | Screw, 8-32 x 3/8" Pan Head |
| - | 4087000 | Lockwasher, #8 Split Ring |
| 22 | 51465 | Torsion Spring, Color Arm |
| 23 | 51929 | Color Arm Assembly, 6-11/16" |
| 24 | 51403 | Pivot Shaft, Color Arms |
| 25 | 00919 | Cotter Pin, 1/16" x 1/2" |
| 26 | 4107101 | Flatwasher, #10 S.A.E. |
| 27 | 51922 | Rocker Catch Assembly, Short |
| - | 51506 | Rubber Pad, Short |
| 28 | 17219 | Compression Spring, Release Button |
| 29 | 51923 | Rocker Catch Assembly, Long |
| - | 51505 | Rubber Pad, Long |
| 30 | 90473 | Compression Spring, Release Button |
| 31 | 00919 | Cotter Pin, 1/16" x 1/2" |
| 32 | 51467 | Washer, Color Release Button |
| 33 | 51397 | Color Release Button |
| 34 | 51395 | Rocker Catch Shaft |

PARTS LIST, Figure 10 (continued)

| <u>Item</u> | <u>Part No.</u> | <u>Description</u> |
|-------------|-----------------|----------------------------------|
| 35 | 01475 | Cotter Pin, 1/16" x 3/8" |
| 36 | 51356 | Cover, Boomerang Housing |
| - | 4080506 | Screw, 8-32 x 1/2" Pan Head |
| 37 | 51166 | Retaining Screw, Boomerang Cover |
| 38 | 51930 | Color Arm Assembly, 6-3/16" |
| 39 | 51931 | Color Arm Assembly, 5-11/16" |
| 40 | 51932 | Color Arm Assembly, 5-3/16" |
| 41 | 51933 | Color Arm Assembly, 4-11/16" |
| 42 | 51934 | Color Arm Assembly, 4-3/16" |
| 43 | 51378 | Mounting Bracket, Left |
| 44 | 51399 | Spacer |
| 45 | 51400 | Stop Shaft |
| 46 | 51401 | Rubber Stop |
| 47 | 19893 | Boomerang Heat Filter Assembly |
| - | 47231 | Bracket |
| - | 47232 | Heat Filter Mounting Disc |
| - | 47233 | Heat Filter |
| - | 46150 | Assembly Clip |

PARTS NOT SHOWN

| | |
|---------|---|
| 51913 | Boomerang Housing & Hinge |
| 51471 | Rubber Bumper Pad, 7" x 8" |
| 4080310 | Screw, 8-32 x 5/16" Pan Head |
| 4088001 | Hexnut, 8-32 |
| 4087004 | Lockwasher, #8 |
| 51355 | Boomerang Housing Support Casting, Rear |
| 4080372 | Screw, 8-32 x 3/8" Flat Head |
| 51864 | Auxiliary Color Holder (replaces UV Filter) |

NOTE: Color temperature reduction filters, required for use with television and videotape, are available from theatrical supply dealers.

