

INSTRUCTION MANUAL

XENON GLADIATOR IV

Follow Spotlight

Type 47070

Rev. May 2004



STRONG INTERNATIONAL

a division of Ballantyne of Omaha, Inc.
4350 McKinley Street
Omaha, Nebraska 68112 USA
Tel 402/453-4444 • Fax 402/453-7238
www.strongint.com

PREFACE

STRONG INTERNATIONAL'S XENON GLADIATOR IV Model 47070 is a direct current follow spotlight system complete with a lamphouse, xenon power supply, optical system, color boomerang, and base stand assembly. The spotlight assembly consists of the arc lamp, variable focus lens system, color boomerang, and base. The separate xenon power supply completes the installation.

ONLY THE SPECIAL XENON POWER SUPPLIES manufactured by Strong International can be used with the Gladiator IV. For installation and operation of the power supply, see the instruction manual furnished separately.

THE XENON LAMPHOUSE utilizes a 4000 watt xenon bulb designed for horizontal operation, and a deep ellipse metal reflector, as a light source. The reflector is designed to operate in a fixed position, and is dichroic ("cold") coated to reduce heat in the projected light. A lens blower and heat filter, mounted in the spotlight optical system, further reduce heat at the projection lens and color media.

ONLY XENON BULBS designed for horizontal operation should be used in this follow spot. The Gladiator IV system includes a Type HS (Horizontal Short) 4500 watt bulb, and replacement bulbs (4000-4500 watt, not exceeding 4500 watts) must be certified as 100% interchangeable with this bulb. All required bulb cabling and contact clamps are provided in the xenon lamphouse, and bulb adapters are not required.

ADJUSTMENT CONTROL for the xenon bulb is located at the rear of the lamphouse behind the access cover. The adjustments control the horizontal, vertical and focal movement of the bulb.

INSTRUMENTATION of the lamphouse includes a digital running time meter with DC voltage and amperage display. A "wattage" readout on the digital display is an *approximate* figure and should not dictate the bulb's output setting. The running time meter records the elapsed hours of the bulb (resettable), and the total hours that the spotlight system has been in operation. A rocker switch controls lamp ON/OFF.

THE LAMPHOUSE COOLING BLOWERS are internally wired and operate on AC voltage derived from the xenon power supply. These blowers are required to maintain a safe operating temperature at the bulb seals. An additional blower cools the optical system and color boomerang. The blowers operate continuously until the xenon power supply is de-energized.

THE LAMPHOUSE is supplied with a 13 foot cable containing the DC leads, the AC control wires, and the ground wire. The cable terminates in a multiple-pin, quick-disconnect plug keyed to mate with the receptacle on the power supply.

WHEN TRANSPORTING THE SPOTLIGHT, it is necessary to remove the xenon bulb and place it in its original shipping container to prevent breakage. See the SAFETY PROCEDURES section following, and permit only authorized personnel to handle the xenon bulb.

IF AT ANY TIME you have a suggestion, or desire aid in securing anticipated results, write directly to STRONG INTERNATIONAL, 4350 McKinley Street, Omaha, Nebraska 68112 USA, or online at www.strongint.com.

XENON GLADIATOR IV

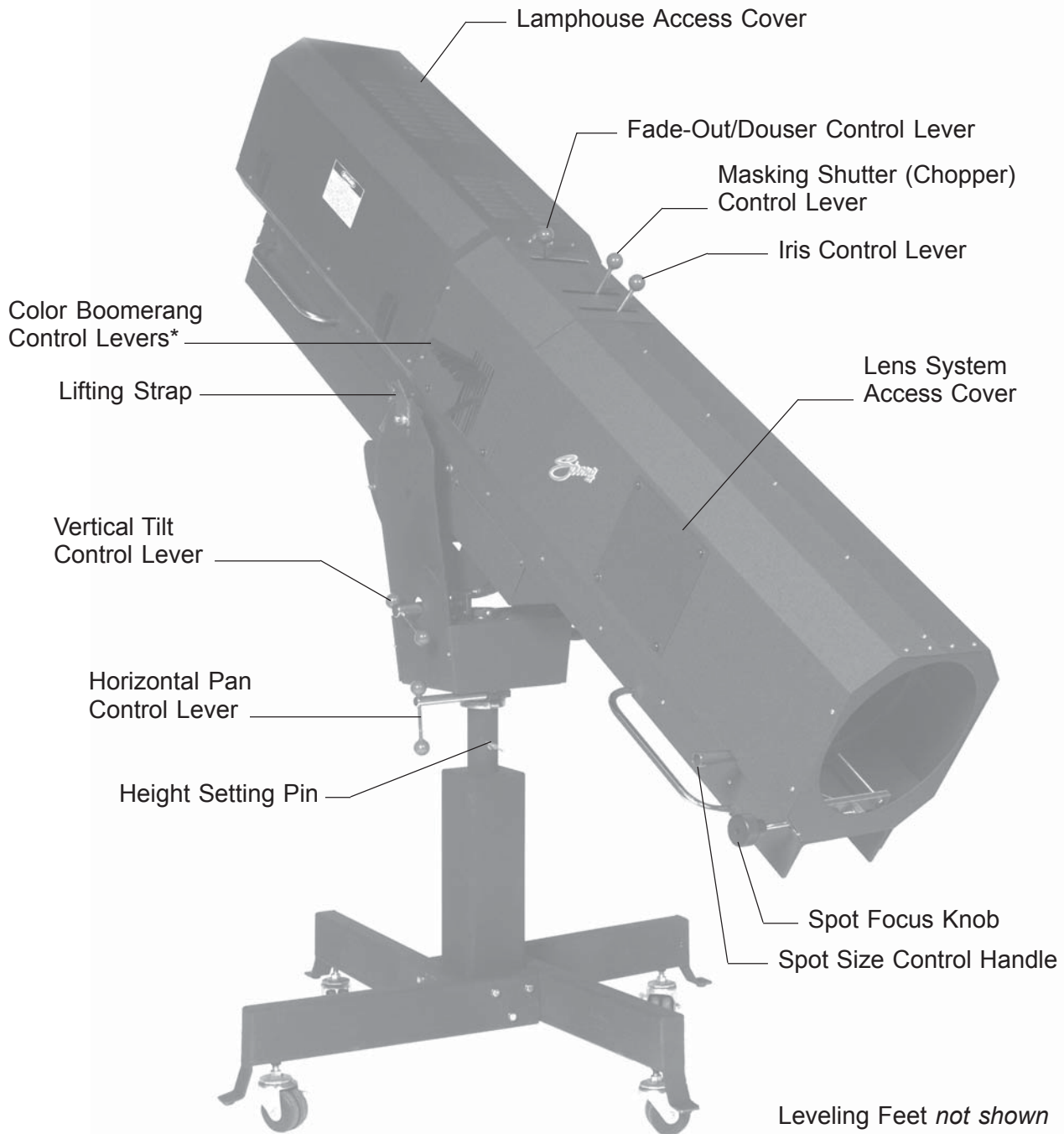

Boomerang Type 72-00264; Type 72-00709 *not shown*: see Figure 5B

INSTALLATION AND SETTING UP SPOTLIGHT

THE XENON GLADIATOR IV is shipped in sections which must be assembled. Lifting straps on the yoke assembly permit completely assembling the spotlight on the floor and later hoisting it to an elevated position.

ASSEMBLE THE FOUR BASE LEGS to the lower square section of the base column using the 3/8-16 x 2-3/4 inch hex head cap screws and lockwashers provided. Insert a leveling foot and locknut in each of the four leg brackets and level the base before continuing the installation.

WHEN INSTALLED in a permanent location, the casters and leveling feet must be removed, and the clearance holes in the base leg brackets used for hardware (user supplied) to bolt the base to the floor or platform. If it is desired to have the unit portable, when operating, the leveling feet *must* be adjusted down until the weight of the spotlight has been shifted from the casters to the leveling feet.

THE INNER TUBE of the support yoke has three holes to permit adjusting the height of the spotlight. The three holes are on four-inch centers and will allow an optical height of approximately 53 inches, 57 inches, and 61 inches above floor level to the optical center of the lamphouse and lens system. Insert the height location pin through the hole in the outer tube and one of the holes in the inner tube. The leveling feet may be adjusted through an additional two-inch range.

THE HORIZONTAL SWING and vertical tilt locking knobs are on the right hand (operating) side of the yoke assembly. Level the yoke and tighten both of these locking devices securely before attempting to place the lamphouse and lens system on the support yoke.

PLACE THE LAMPHOUSE and lens system on the yoke assembly, with the spot size control handle to the right hand (operating) side, the same as the locking controls on the yoke. Line up the four tapped (5/16-18) mounting holes in the bottom of the base rail mounting bracket with the four mating holes in the support yoke and secure using the four 5/16-18 wing screws. Note the mounting holes are slotted to allow fine adjustment for balancing the spotlight.

ATTACH THE LAMPHOUSE CABLE CONNECTOR to the mating receptacle on the power supply. The lamphouse and power supply connectors are keyed for correct pin alignment; make certain pins are seated before tightening the locking ring. DO NOT energize the xenon power supply before the xenon bulb is correctly installed into the lamphouse.

LAMPHOUSE - POWER SUPPLY Interconnection Diagram

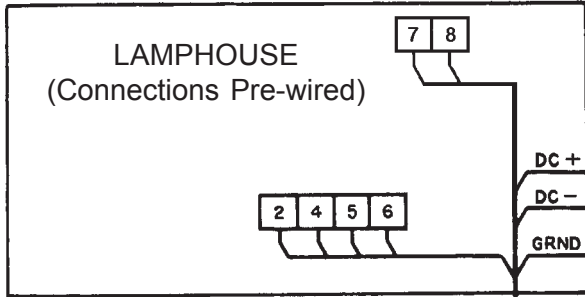

MS CONNECTOR

Pin	Wire No.
A	DC-
B	DC+
C	2
D	3
E	4
F	5
G	6
I	7
J	8
M	Grnd

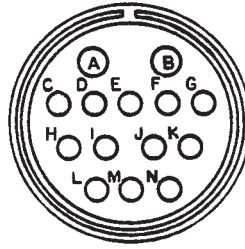

Lamphouse
Cable Assembly

SYSTEM MUST BE GROUNDED
All wiring must conform to local codes;
shield lamphouse cable in conduit
if required.

Check Slide Switch (below) on Power
Supply for correct positioning.

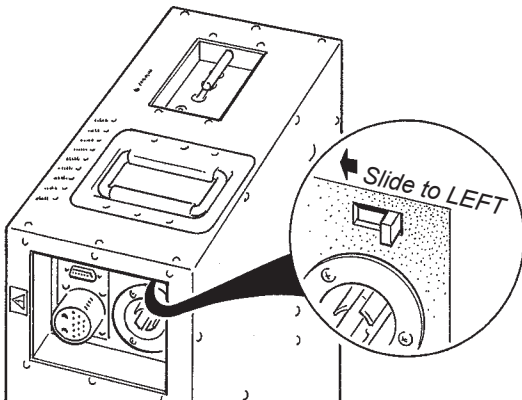
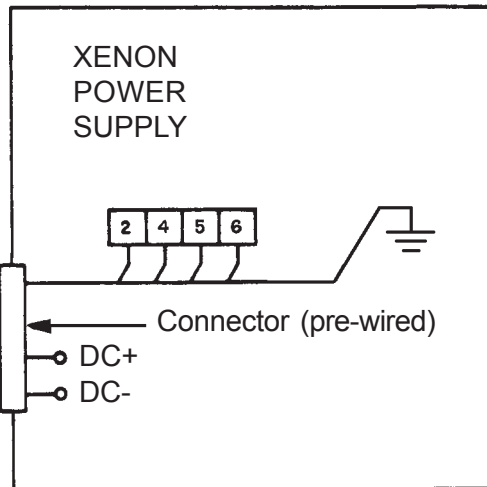

SAFETY PROCEDURES



READ CAREFULLY BEFORE INSTALLING XENON BULB



THE XENON BULB is highly pressurized. When ignited, the normal operating temperature of the bulb increases the pressure to a level at which the bulb may explode if not handled in strict accordance to the manufacturer's operating instructions.

THE BULB is stable at room temperature, but may still explode if dropped or otherwise mishandled. Breakage resulting from transport and handling is *not* covered by the bulb manufacturer's warranty, and it is strongly recommended to dismount the xenon bulb when transporting the spotlight.

REFER bulb replacement and service to QUALIFIED PERSONNEL with adequate protective clothing (face shield, clean cotton gloves, welder's jacket). For routine lamphouse service, observe the following rules:

1. Allow the bulb to cool to room temperature before opening the lamphouse. Put on protective clothing described above.
2. De-energize the xenon power supply at the AC source before opening the lamphouse compartment.
3. When possible, encase the bulb in its protective cover when cleaning or servicing the lamphouse interior. The bulb, when outside the lamphouse, must be encased in the cover.
4. Clean the bulb after it has cooled to room temperature. Do not touch the quartz envelope of the bulb; fingerprints will burn in and create hot spots which may shorten bulb life. If fingermarks are made, they should be carefully removed with methyl alcohol and cotton prior to bulb operation.
5. Never view an ignited bulb directly. **BLINDNESS OR PERMANENT EYE DAMAGE MAY BE INCURRED.**
6. Use only xenon bulbs designated as OZONE FREE. When possible, vent the lamphouse exhaust to outside atmosphere.
7. Maintain the lamphouse blowers in good operating condition. Keep the blower inlets and grilles clean for unrestricted air flow.
8. To insure maximum bulb life, operate the lamphouse blowers for **at least** ten minutes after extinguishing the bulb.
9. If returning a bulb for warranty adjustment, pack it in its original shipping container. Complete and return all required warranty information.

10. Dispose of expired bulbs that are beyond warranty in the following manner: Wrap the bulb tightly in several layers of canvas or heavy cloth. Place it on a hard surface and shatter the envelope with a sharp hammer blow. DO NOT place an unshattered bulb in an ordinary refuse container.
11. DO NOT PERMIT UNAUTHORIZED PERSONNEL TO PERFORM OR ATTEMPT ANY PHASE OF XENON BULB HANDLING OR SERVICE.

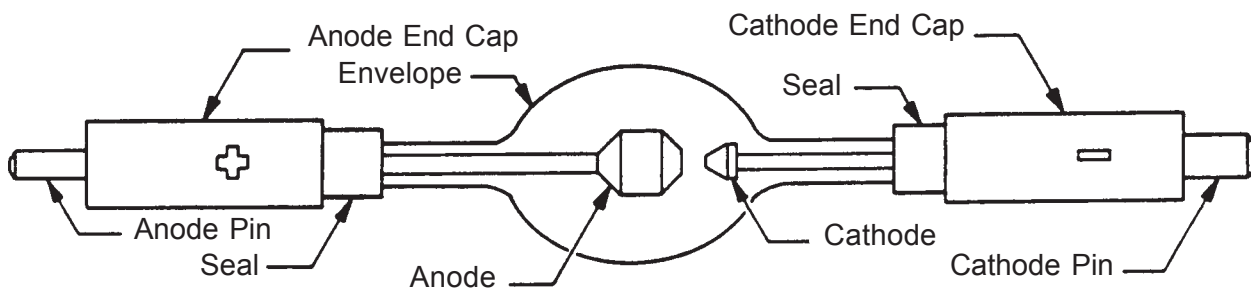

NOTE

For use in a Gladiator IV lamphouse, it is necessary to remove the anode lead (if attached) from the anode end cap of the bulb. Leave the bulb in its protective cover and grasp the bulb by the anode (+) end cap. Use small channel locks or slip-joint pliers and grip the bulb lead fitting at the crimp joint nearest the end cap, and unscrew the lead. If the bulb manufacturer uses a brazed rather than threaded connection, cut the lead from the end cap, cutting as close as possible to the end cap.

BULB INSTALLATION

OBSERVE ALL SAFETY PROCEDURES when working around the xenon bulb. Open the lamphouse access cover by releasing the clasps and swinging the cover up to its stop. Loosen the (5) quarter-turn fasteners and remove the two bulb compartment side covers. The bulb leads and contact clamps are tied down for shipping. Free the clamps and slide the anode clamp over the brass socket of the rear support collet.

REMOVE THE PLASTIC PROTECTIVE COVER from the xenon bulb only if necessary. Handle the bulb by the metal end caps *only*. Dismount the anode lead from the (+) end cap of the bulb if attached. Grasp the bulb by the metal anode (+) end cap *only* when unscrewing the lead from the bulb; DO NOT hold the bulb at the cathode (-) end cap when removing the anode lead.

INSERT THE BULB into the lamphouse, passing the anode (+) end cap through the center hole of the reflector. Take care not to bump or scratch the surface of the reflector. Insert the anode (+) pin into the rear support collet and contact clamp. Rest the cathode (-) end cap in the front bulb support yoke. Seat the anode (+) pin into the rear support collet as far as possible for correct focus travel. Securely tighten the socket head clamping screw in the anode contact.

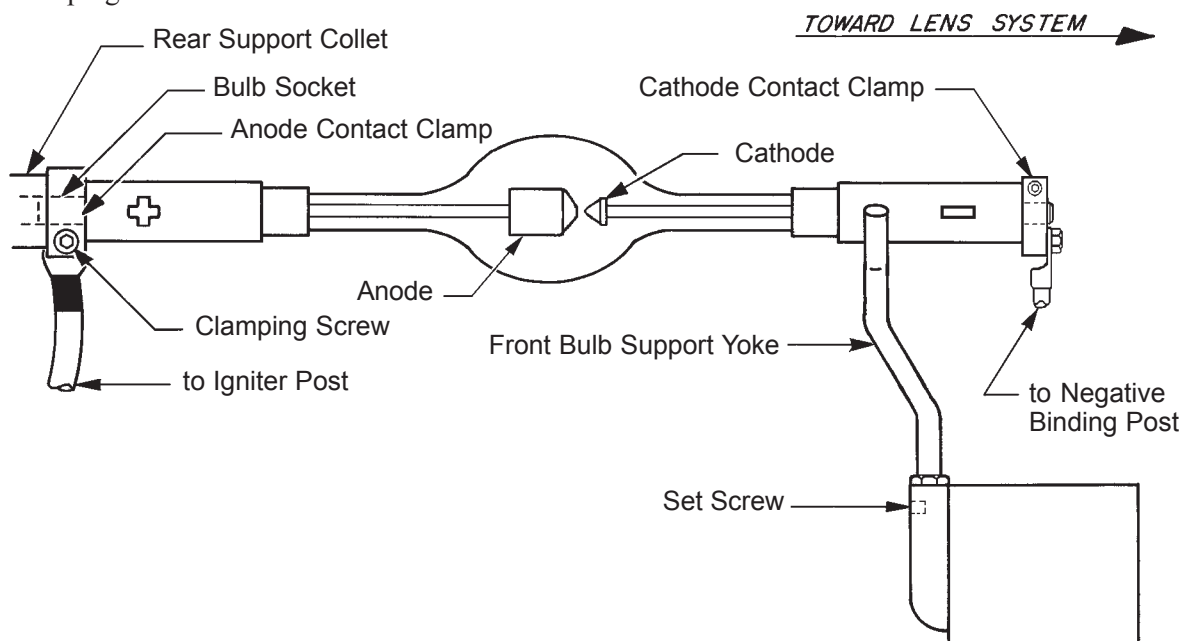

REST THE CATHODE END CAP in the "V" of the bulb yoke. Dress the bulb lead directly in front of the bulb support yoke to minimize the projected shadow, but do not allow it to touch grounded metal lamphouse components; the bulb yoke and the support casting are insulated from ground. Slide the cathode contact clamp over the cathode (-) pin and securely tighten the clamping screw.

REMOVE THE PLASTIC COVER from the bulb. Record the bulb serial number, date, and lamphouse hours on the Xenon Bulb Record on the inside back cover of this manual. Replace the bulb enclosure covers and secure the quarter-turn fasteners. Use of these covers maximizes bulb cooling for long life.

ESTABLISH A ROUTINE of periodically checking all electrical connections for tightness. Loose contacts, particularly in the DC circuit, will cause overheating and damage the xenon bulb and other components. Normal xenon bulb warranties allow **no credit** for bulb damage caused by overheating.

REFER TO THE BULB MANUFACTURER'S INSTRUCTIONS regarding bulb rotation. Most bulb manufacturers recommend rotating the bulb 180° at 50% of warranty hours. After rotating the bulb, operate at maximum allowable current for several hours, and then return to the nominal operating current.

IN THE EVENT of a bulb warranty claim, the bulb must be packaged in its original shipping container, and returned with all required warranty forms completed. Contact the dealer through whom the bulb was originally purchased for correct procedures and Return Authorizations.

IT IS A COMMON PRACTICE to replace the bulb at the expiration of its warranty period. If a xenon bulb explodes in operation, the reflector and other lamphouse components are frequently damaged. The xenon bulb manufacturer will extend *no credit* for a replacement reflector if the defective bulb is beyond warranty. Explosion-damaged reflectors are to be returned to the **bulb supplier**, NOT Strong International, unless the bulb was supplied by Strong.

ARC STABILIZATION MAGNET

THE XENON BULB used in the Gladiator IV lamphouse requires an arc stabilization magnet. This magnet is located below and behind the reflector. The magnet is preset at the factory and should not require adjustment. Should it become necessary to adjust the magnet, the following procedure must be followed. Observe all bulb safety procedures when working in the lamphouse compartment.

A NORMAL ARC should appear as shown in Figure "A," and represents the correct magnet position. Figure "B" shows the position of the arc when the magnet is too low; Figure "C" shows the position of the arc when the magnet is too high. Condition "B" or "C" will cause arc flicker. If flicker is apparent in the projected spot, raise or lower the magnet on its slots as required to position the arc as illustrated in Figure "A."

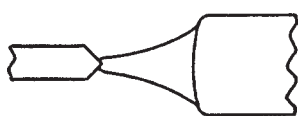

FIGURE A

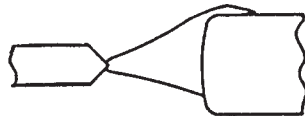

FIGURE B

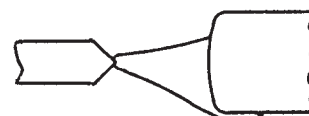

FIGURE C

THE MAGNET must always be installed with the longest portion of the magnet uppermost (nearest the bulb), and with the NORTH (N) pole pointing toward the operator side access door. Reversing the magnet will cause bulb flicker, and may inhibit bulb ignition. In new equipment, the magnet is normally in the center of the adjustment range. Changes in the magnet position are required *only* to correct an improperly burning arc (Figure "B" or "C").

ANY REPLACEMENT MAGNET should first be installed in the center position of the adjustment range. Raise or lower the magnet as required to center the arc as illustrated in Figure "A."

OPERATION

OPEN THE BOOMERANG ACCESS COVER and verify that the round glass heat filter and ring assembly is installed into the bracket mounted to the fadeout and douser support housing. NOTE: The *coated side* of the filter, with the XX or other marking, **must be facing the reflector**.

REMOVE THE PLASTIC COVER from the xenon bulb. DO NOT ignite the lamp with the cover on the bulb. Store the cover for future re-use. Replace and secure the bulb enclosure covers.

CLOSE THE LAMPHOUSE COVER and secure using both latches. Turn on the main line switch and/or circuit breaker to energize the xenon power supply. The spotlight blowers will start and operate continuously until the xenon power supply is de-energized.

PLACE THE **LAMP SWITCH** in the “ON” position and the lamp will ignite. Check the reading on the lamphouse ammeter. Nominal current for the 4500 watt xenon bulb is 135 amperes. DO NOT, AT ANY TIME, exceed 150 amperes; *the “wattage” readout on the digital display is an approximate figure and should not dictate the output setting*. Output current is adjusted at the xenon power supply; see power supply manual for instructions. Operation of a new bulb is normally started at the lower end of its range (125 A.), and current is gradually increased as the bulb ages to maintain light output. During the ignition cycle, the display will also briefly indicate the high “no load” (open circuit) DC voltage applied to the xenon bulb for ignition.

REMOVE THE REAR COVER above the instrument panel by releasing the (3) quarter-turn fasteners. This exposes the bulb positioning controls in the lamphouse back casting. To focus the xenon bulb and obtain the best light on the stage, the two methods outlined below are the most suitable.

MOVE THE SPOT SIZE CONTROL HANDLE (trombone) on the large lens carriage all the way forward to project the smallest spot possible; place the iris, masking shutters (choppers) and the fadeout douser blades in their full open positions. Project a spot to a wall or similar flat perpendicular surface opposite the spotlight position.

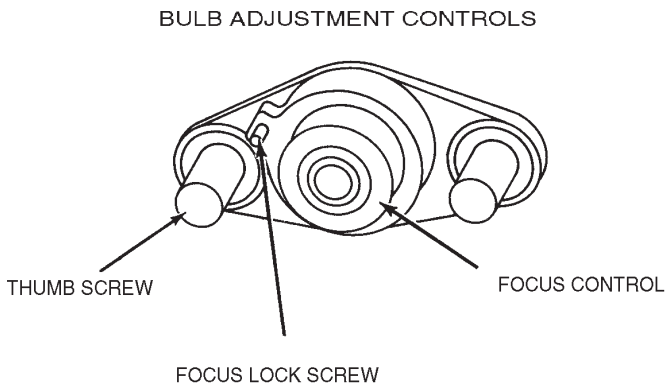

THE CENTER SECTION of the bulb positioning controls is a threaded member that focuses the bulb in relation to the reflector. Turning this adjustment moves the bulb in only one plane, into or away from the reflector. Turning this section clockwise moves the arc away from the reflector. The small knurled screw to the left of this section can be tightened to lock the focusing mechanism after the following procedures have been completed.

THE LARGE THUMB SCREWS, on either side of the focusing control, lock the horizontal and vertical adjustment mechanism in position.

TURN THE CENTER FOCUSING SECTION of the bulb positioning control counterclockwise until a small black spot is projected onto the wall. It may be best to run this adjustment both directions to permit positive identification of the spot.

LOOSEN THE TWO THUMB SCREWS, one on either side of the center focusing section, just enough to permit manual movement of the complete assembly. The bulb positioning control will now move around these two thumb screws, and as this control is shifted, the smooth shadow of the bulb electrode can be seen extending beyond the projected center hole in the reflector. The shadow of the electrode (black spot) must be centered in the projected hole of the reflector (shaded, less dense dark area).

MOVE THE CONTROL SECTION around the two screws until the black spot is as round as possible to project. It may be necessary to again turn the focus control to project a sharply defined black spot.

AFTER THE BLACK SPOT is as even around the outside as possible to project, and appears centered in the shaded reflector center hole (Spot "A"), tighten the two large thumb screws to lock the position of the mechanism. Turn the center focus control to obtain the brightest light with the best light distribution (Spot "B") and continue to the defocused position (Spot "C") to verify that the bulb is centered in the reflector.

IF THE CENTER BRIGHT SPOT tracks off to the left, right, top, or bottom, it may be necessary to reposition the front bulb support yoke to compensate. Loosen the set screw in the support casting and reset the yoke as required. The hex nut may be used to lock the height of the yoke. Secure the yoke with the set screw after the bulb tracks on a straight axis. Return the focus control to the desired Spot "B," and rotate the spot focus control knob, located at the extreme front of the lens mechanism, to obtain the sharpest edge possible on the projected spot.

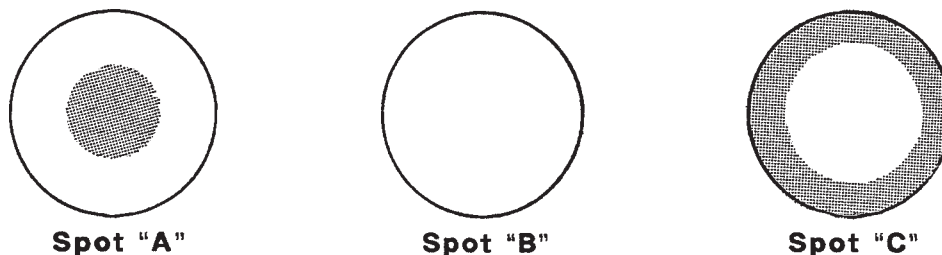

THE SECOND METHOD of focusing the xenon bulb is to project the spot to the stage, and working with the above lamphouse controls, adjust these controls to obtain a "hot spot" on the projected spot. Center this "hot spot" on the projected light by moving the entire control section around the two thumb screws. Once this "hot spot" is centered in the projected light, lock the control in position with the two thumb screws and turn the center section to obtain a spot with an even distribution of light. Rotate the lens spot focus control knob to obtain a sharp edge on the projected spot.

THESE ADJUSTMENTS should not be disturbed until after replacing or rotating the xenon bulb. At that time, the procedure on obtaining a smooth, round black spot, or "hot spot," may have to be repeated. Replace the cover plate over the bulb positioning controls and secure with the (3) quarter-turn fasteners.

BECAUSE OF NORMAL BULB AGING, and manufacturing tolerances between individual xenon bulbs, it may be necessary to operate different lamps at slightly higher or lower current settings to achieve balanced, uniform light output when two or more spotlights are used in one installation. This entails a slight current output adjustment at the xenon power supplies. See the power supply manual.

TO EXTINGUISH the arc, place the LAMP switch on the instrument panel to "OFF." The lamphouse blowers will continue to operate until the xenon power supply is de-energized. Allow the blowers to operate for ten minutes before turning off the power supply; a forced-air bulb cooling cycle at shutdown is *required* by all bulb manufacturers to comply with their warranty terms.

BEFORE OPENING the lamphouse enclosure for servicing, allow the blowers to operate for twenty minutes, or until the bulb has cooled to room temperature.

HANDLING THE SPOTLIGHT

GENERALLY THE BEST POSITION for the operator to stand is near the center of the spotlight on the right side. The angle of tilt, the size of the porthole, and the layout of the spotlight position may dictate another location.

EACH OPERATOR will, after a few minutes of operation, generally develop his own system and position for most convenient operation.

THE HORIZONTAL SWING and vertical tilt are individually adjustable to give the desired degree of friction to suit the operator. The locking clamps are located on the right side of the yoke assembly.

THE EASE with which the spot size control handle ("trombone") can be operated may be adjusted by means of the nylon friction brake screw in the outrider of the large lens carriage casting. To access this adjustment, remove the access panel (four quarter-turn fasteners) from the operator side of the optical system cover. Turn the nylon friction screw clockwise to increase drag, or counterclockwise to relieve. Tighten the locknut after the desired tension is reached.

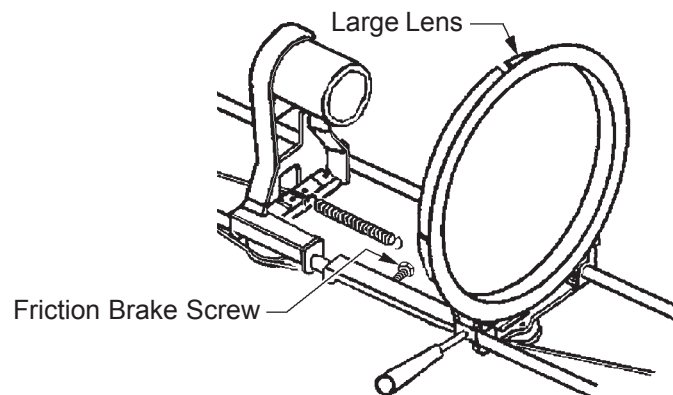

OPERATION OF OPTICAL SYSTEM

THE IRIS CONTROL is the front lever which projects through the top of the optical system housing. When this lever is to the left (as viewed from the rear of the unit), the largest aperture is provided. Smaller apertures are obtained as the lever is moved to the right.

THE SPOT SIZE CONTROL HANDLE is located on the right hand side of the optical system just above the base rail. A variation of spot sizes from full flood to small spot can be obtained by moving the spot size control handle from one extreme to the other. Beam intensity is increased by this optical system when reducing from flood to spot, and maximum intensity is reached when the spot size control handle is in the extreme forward position. Rotating the handle allows a slight degree of spot focus.

THE MAXIMUM FLOOD SPOT is obtained with the iris control lever to the left (away from operating side) for the largest aperture and with the spot size control handle moved as far to the rear as possible.

SMALLER SIZED SPOTS are projected as the spot size control handle is moved forward. Most of the spot sizes needed will be produced with the iris in its maximum open position.

FOR A "HEAD SPOT," or any spot smaller than can be obtained with the spot size control handle in its extreme forward position, shift the iris control lever to the right (toward operating side) for a smaller aperture. The iris control lever should always be returned to its extreme left position before the spot size control handle is again moved to obtain larger spots.

THE MASKING SHUTTER (chopper) lever is the middle lever projecting through the top of the optical system housing. The masking shutter blades are operated by this lever to shape the projected spot to a rectangle, strip spot, or dousing.

THE DISENGAGED POSITION of the masking shutter lever is to the extreme right (toward operating side) and varying degrees of masking to complete cutoff are obtained by moving the lever to the left (away from operating side). If dousing the spot for a prolonged period with the bulb operating, it is highly recommended to use the *Fadeout* doublers (below) to prevent heat damage to the masking shutter blades.

THE ANGLE of the masking shutter blades can be adjusted to compensate for the horizontal projection angle. Remove the color arm cover plate and dismount the boomerang. Loosen the (4) screws holding each of the masking shutter blades enough to allow adjustments. Ignite the bulb and adjust the angle of the *bottom* blade by tapping with a screwdriver so its projected edge lies parallel to the footlights. Tighten the screw. Operate the masking shutter lever to close the blades. Adjust the upper blade to close in line with the bottom blade and tighten the screw.

THE FADEOUT MECHANISM AND DOUSER CONTROL is the rear lever projecting through the top of the optical system cover. This lever controls the intensity of light from complete fadeout when the lever is to the left, to full intensity when the lever is to the right.

THE SPOT FOCUSING CONTROL KNOB is located on the operating side of the optical system at the forward end above the base rail. This control is used to adjust the optical system for the length of throw. When making an adjustment, rotate the spot focusing control knob until the sharpest edge is obtained on the projected spot.

OPERATION OF COLOR BOOMERANG

THE COLOR BOOMERANG supplied with the Gladiator IV is selected when first ordering the spotlight from the factory. The Type 72-00264 boomerang is mounted within the optical system and uses (6) 50mm dichroic discs as the color media. Type 72-00709 mounts to the front of the lens barrel and uses conventional high-temperature color gels (i.e. Roscolux®) as color media.

EACH BOOMERANG is equipped with six color arms. A “starter” set of six 50mm dichroic color discs, or six sheets of commonly-used color gel, is included. Additional colors, including color temperature reduction filters, are available from most theatrical supply dealers.

COLOR FILTERS are controlled by the six color levers of the boomerang. To engage an individual color filter, lower the desired filter selector lever. A rocker catch located in the color disc housing holds the filter in the light beam. To release a color, lower the filter release lever or engage another color, thus releasing the previous color automatically.

TO REPLACE A COLOR FILTER in the 72-00264 boomerang (see Parts List, Figure 5A), it is recommended to dismount the entire assembly from the optical system and place it on a convenient working surface. Loosen the (2) quarter-turn fasteners and remove the side cover plate. The entire boomerang assembly can then be easily removed by loosening the single captive screw securing the boomerang bracket to the base rail, and lifting the bracket off the (2) locating pins. When re-installing the boomerang, align the holes in the boomerang base plate onto these pins before again securing the captive screw.

TO ATTACH A COLOR GEL to the gel ring of the front-mounted 72-00709 boomerang (see Parts List, Figure 5B), spray the flat surface of the ring (without the channel clip) with an aerosol adhesive. Center the ring over a precut 13½ by 13½ inch (34 x 34cm) gel, and press the adhesive-coated side onto the gel. Trim the excess gel material and install the ring into the boomerang.

NOTE: WHEN INSTALLING COLOR FILTERS in either boomerang, the *less* dense colors (pink, amber) should be placed in the holders toward the **rear** of the boomerang (toward arc), and those of *greater* density (red, green) should be placed in the holders toward the **front** of the boomerang (away from the arc). This measure will prolong the useful life of the filters.

DIGITAL DISPLAY

UPON ENERGIZING the LAMP circuit, the backlighting will illuminate the LCD screen. The display **CHECK TOP COVER** will appear if the top cover is not secured. When the lamphouse access cover is closed and correctly secured, and the blowers are operating, the display will appear as shown:

000V 000A 0000W
1234BLB 12345HR *

FOR PURPOSES OF ILLUSTRATION, the above display indicates a non-operating bulb with 1,234 hours of use installed into a spotlight with 12,345 hours of operation. The asterisk (*) at the end of the second line, when flashing, indicates that the display is active and awaiting input. Upon bulb ignition, the upper line will display the arc voltage (V), the DC current (A), and the operating wattage (W) of the bulb. *The "wattage" readout on the digital display is an approximate figure and should not dictate the DC output setting.* The figures will shift for the first few moments of bulb operation, but will stabilize after the bulb reaches normal operating temperature and pressure. A plus sign (+) will replace the asterisk.

CLOSURE OF THE **LAMP SWITCH** will energize the contactor of the xenon power supply. The high open circuit ("no load") DC voltage will be displayed. When the open circuit voltage reaches 140 V.DC, the igniter will generate a RF pulse to bridge the gap between the bulb electrodes. This pulse, coupled with the high open circuit DC voltage, will ignite the bulb. The voltage reading (V) will then fall to the bulb's sustaining level, and the DC amperes (A) and wattage (W) will be displayed continuously until the bulb is extinguished.

ELAPSED HOURS will begin counting upon bulb ignition. Bulb hours (BLB) are limited to four digits, and must be re-set when the xenon bulb is replaced. To re-set bulb hours, press the RESET button accessible through marked hole below the LCD screen. The 5/64" allen wrench supplied with the accessory kit is the correct diameter to clear the hole.

NOTE: WHEN RECORDING start-up and removal hours on the Xenon Bulb Record, use the **total elapsed hours** (HR) figures. The (BLB) figure, re-set upon installation of the bulb, is a convenience feature ONLY. Basing records of the lamp system on the total hours (HR) figures permits an accurate and ongoing history of bulb usage.

IF THE XENON BULB fails to ignite, the following diagnostic messages will display on the lower line of the LCD screen:

CHECK PWR SUPPLY: If no DC current is sensed, and voltage does not exceed 125 V.DC, check the xenon power supply. Repair or replace as required.

CHECK IGNITER: If the DC open circuit voltage reaches and exceeds 140 V.DC and the igniter fails to pulse, replace the igniter.

CHECK XENON BULB: Check the DC cables connected to the bulb. If the high voltage is shorting to ground, and not arcing between the bulb electrodes, locate and correct (insulate) the short circuit. If the high voltage arc appears between the bulb electrodes, and the bulb fails to ignite, replace the bulb.

DIAGNOSTIC MESSAGES serve as prompts and suggestions but do not replace traditional troubleshooting procedures. If the top cover is closed and secured but transmits an error message, check the subject cover interlock switch with an ohmmeter and replace if defective. Dirt or dust fouling an air vane switch will cause a “blower” error message. A “power supply” or “igniter” error message might be caused by a loose or oxidized connection.

MAINTENANCE



CAUTION: DISCONNECT AC POWER BEFORE SERVICING



THE XENON GLADIATOR IV SPOTLIGHT requires very little maintenance to keep it in good working order.

THE REFLECTOR should be cleaned periodically with a soft, clean, lint-free cloth to remove dust from the reflecting surface. If excessively soiled, the reflector may be cleaned with Windex® or an equivalent glass cleaner. DO NOT use abrasive cleaners of any kind. Clean the heat filter glass; replace with the coated surface toward the lamphouse.

CHECK ALL ELECTRICAL CONNECTIONS for tightness on a regular basis. Loose connections, particularly in the DC circuit, may cause premature bulb failure and damage lamphouse components.

LUBRICATE the (3) squirrelcage blower motors with two or three drops of non-detergent oil once every six months.

THE XENON BULB should be checked occasionally for the presence of dust or foreign materials on the quartz envelope. If necessary, clean the envelope with alcohol, and wipe dry with a clean, lint-free cloth. Observe all safety procedures when working with the exposed bulb.

THE INSIDE OF THE LAMPHOUSE and the blower squirrelcages should be cleaned periodically, depending on the dust conditions at each installation. Keep the blower inlet and outlet grilles clean to permit free air flow.

THE LENS SYSTEM should be kept clean to prevent any light reduction in the projected spot. Tighten the horizontal swing and vertical tilt locking clamps. Remove the operator-side optical system access panel to clean the back surface of the large lens and access the small projection lens which is held in place with a large spring-type retainer ring at the front of its lens barrel.

CLEAN THE PROJECTION LENS and large lens with with any cleaner approved for use on coated projection lenses. Replace the Buhl projection lens with the end with the FL marking ring toward the iris; the ISCO lens tube has arrows indicating the end nearest the iris. Secure with the retainer ring.

BEFORE TRANSPORTING the spotlight, remove the xenon bulb from the lamphouse. Place the bulb in its plastic cover and original shipping container.

LAMPHOUSE WIRING DIAGRAM

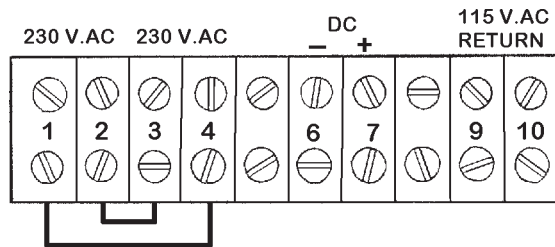
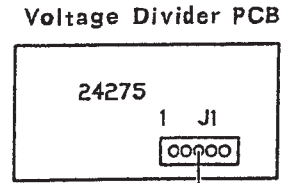
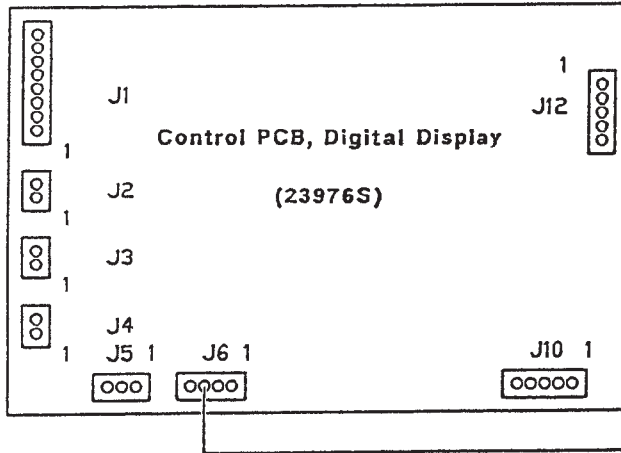
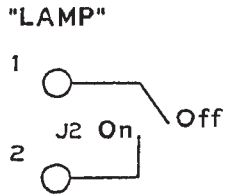
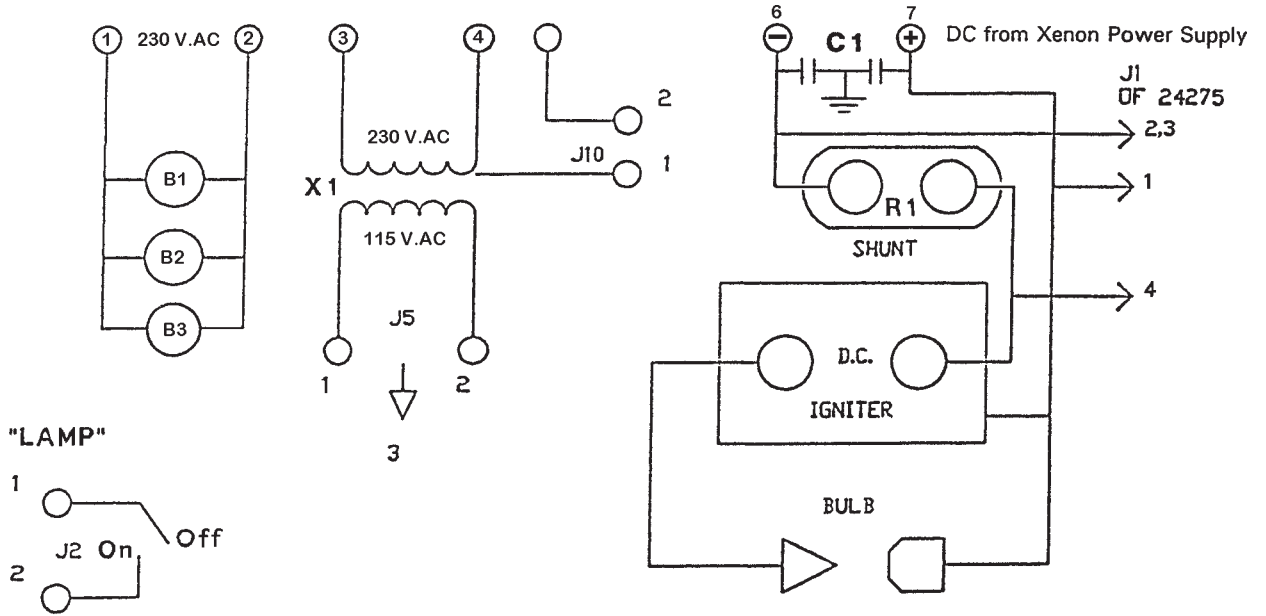

WIRING DIAGRAM PARTS LIST

<u>Part No.</u>	<u>Description</u>
81-33026	Blower, 230 V.AC, 50/60 Hz. (B1,B2,B3)
72-00255	Capacitor, RF Suppression (C1)
81247000	Shunt (R1), 200 A. 50 mV.
24086000	Rocker Switch, ON/OFF
72-00253	Transformer (X1)
39862000	Igniter
24275000	Printed Circuit Board Assembly, Voltage Divider (mounts to R1)
23976S00*	Printed Circuit Board Assembly, Digital Display Control
24087000*	LCD Display Screen
31-30231	Xenon Bulb, LTIX4500W-HS
72-00251	Interconnect Cable Assembly, Lamphouse/Power Supply (see Figure 8)
72-00252	Terminal Board & Molex Wired Assembly
21-62012	Barrier Strip, (10) Terminal

* see Figure 3, Item 45

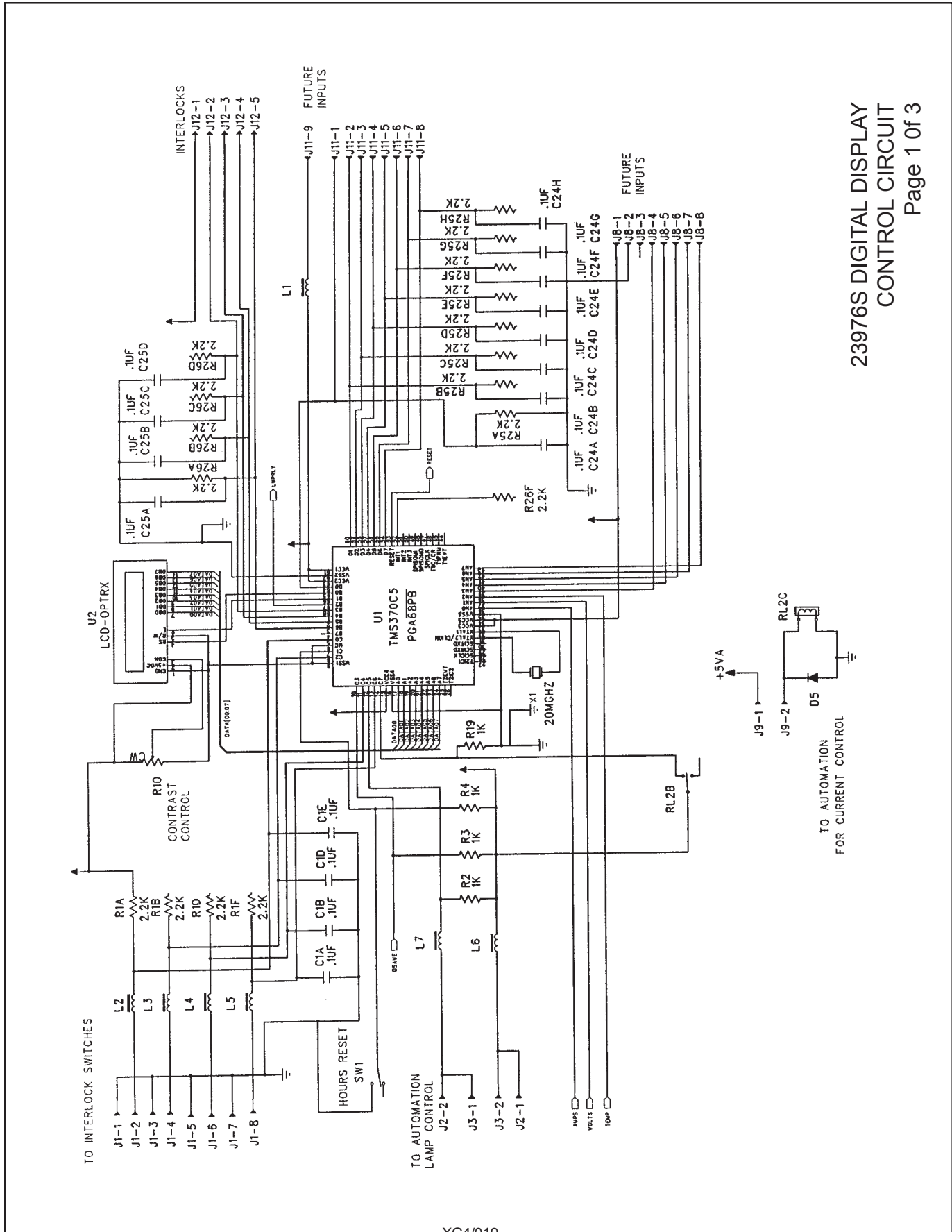

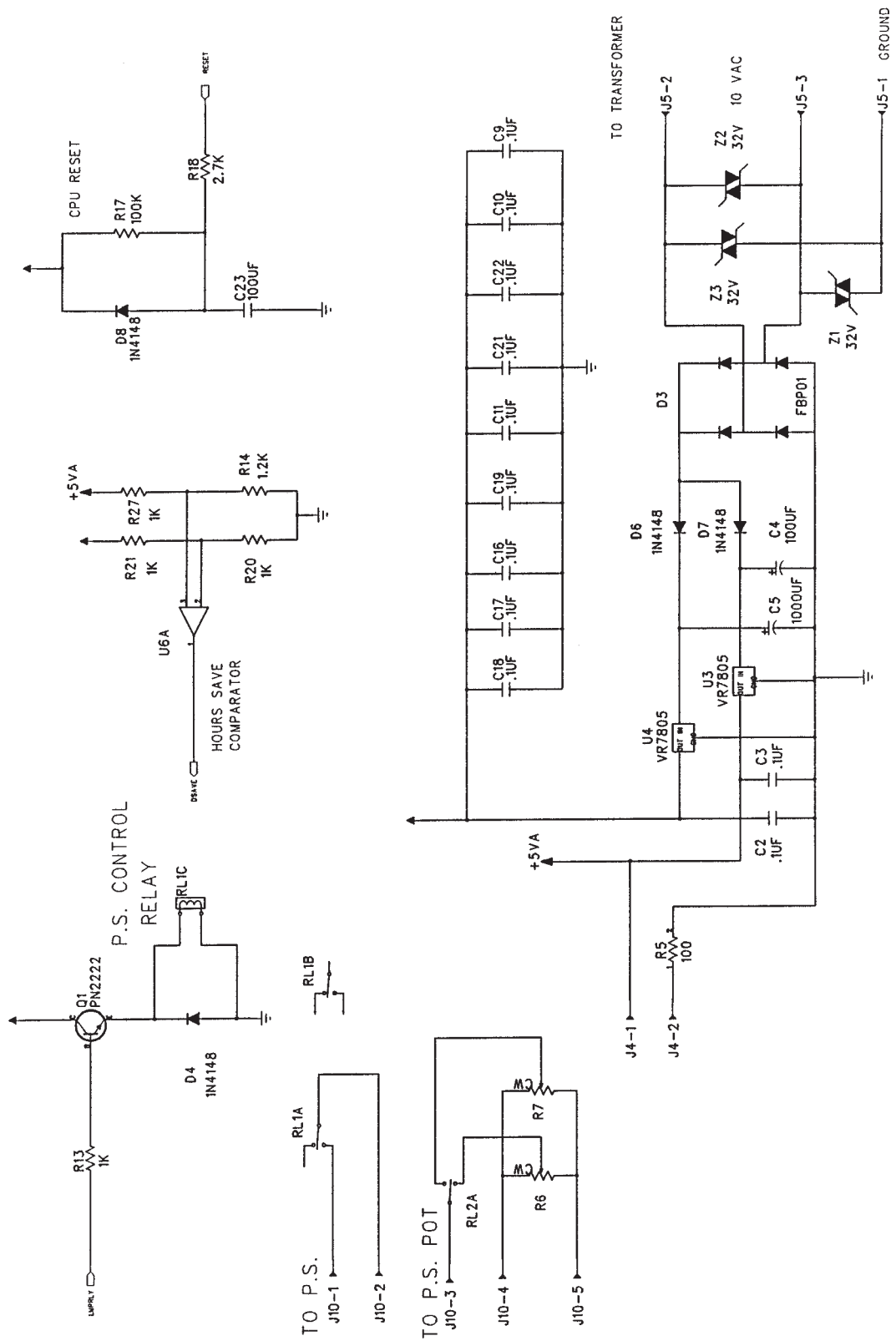

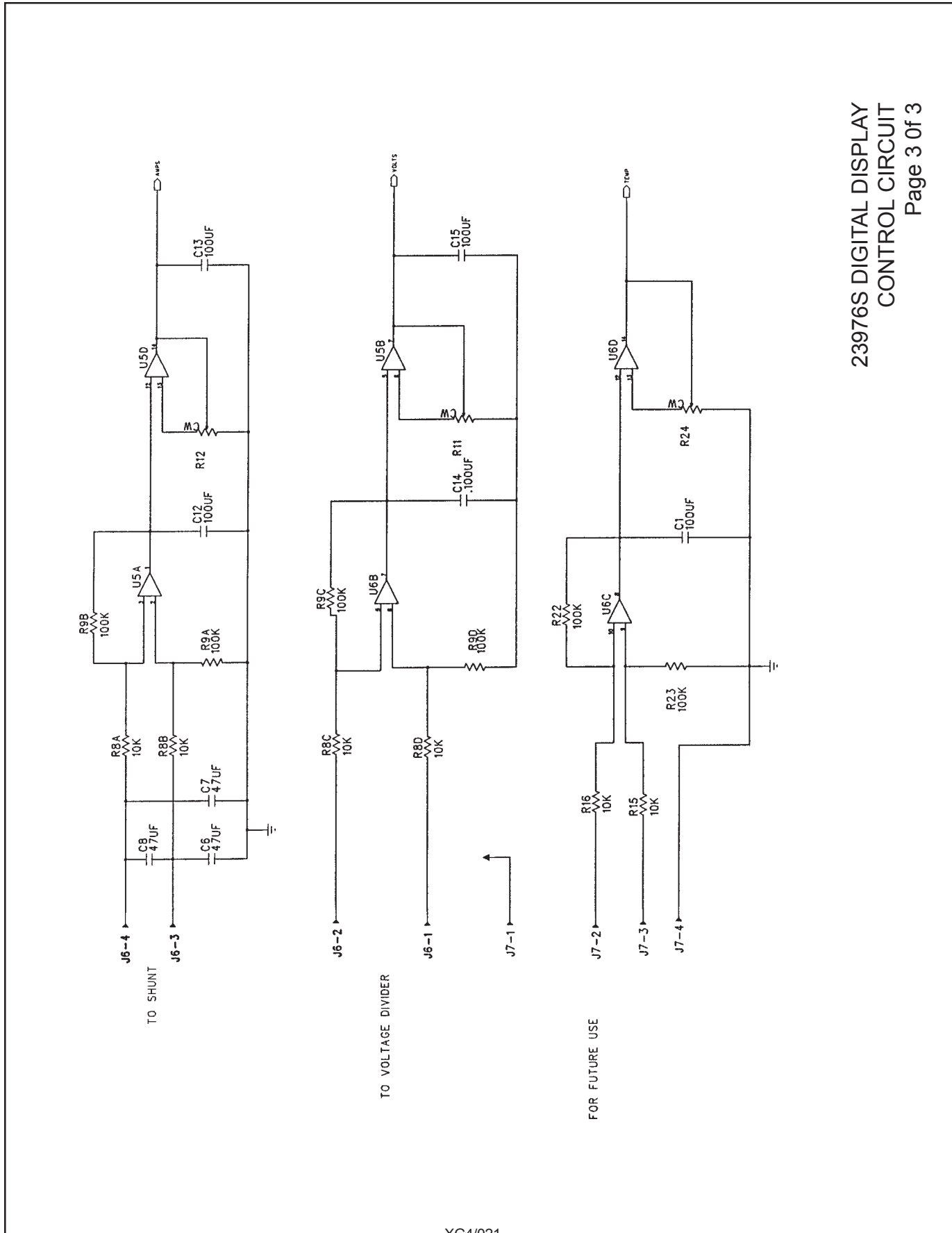

VOLTAGE DIVIDER ASSEMBLY

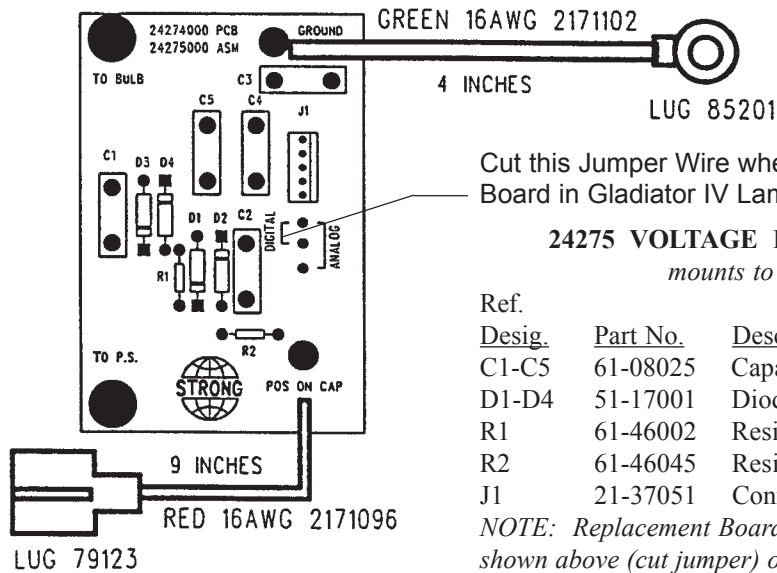

Cut this Jumper Wire when using 24275 PC Board in Gladiator IV Lamphouse

24275 VOLTAGE DIVIDER BOARD *mounts to R1 Shunt*

Ref.	Desig.	Part No.	Description
	C1-C5	61-08025	Capacitor, .005 μ f, 3 kV.
	D1-D4	51-17001	Diode, 1N4007
	R1	61-46002	Resistor, 100 Ohm, 1/4 W. 5%
	R2	61-46045	Resistor, 100k Ohm, 1/4 W. 5%
	J1	21-37051	Connector, (5) Position

NOTE: Replacement Board must be modified as shown above (cut jumper) or board will not function!

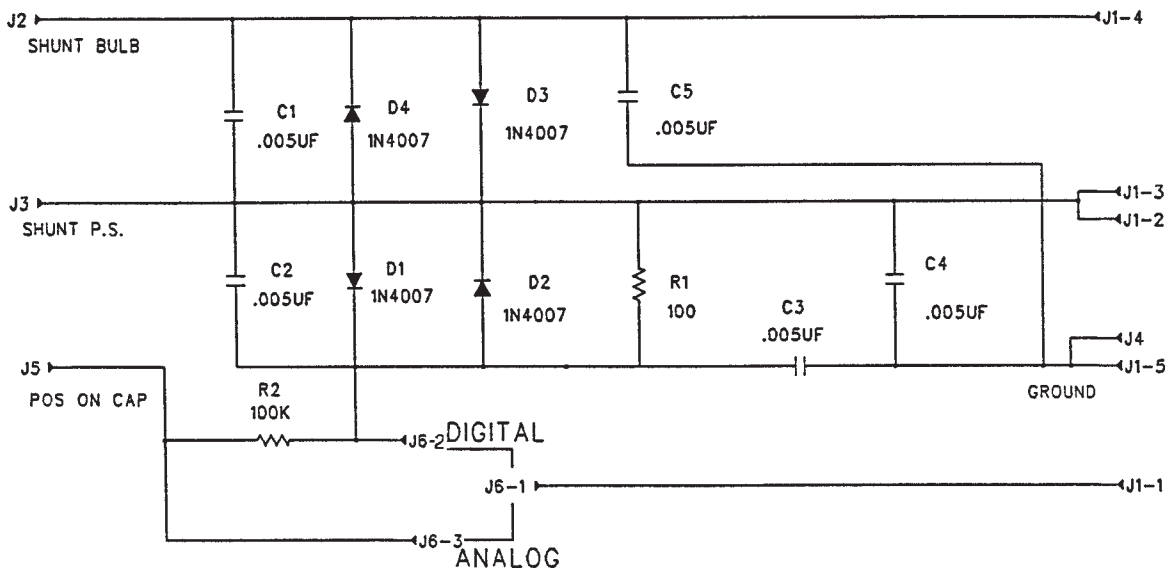

TROUBLE CHART

NORMAL OPERATION

WHEN THE SWITCH in the main AC supply line to the xenon power supply is in the ON position, and the 30 A. circuit breaker on the switching power supply is ON, the POWER lights on the xenon power supply and the lamphouse instrument panel will glow. The lamphouse blowers will start. The blowers in the power supply will operate.

WHEN THE LAMP SWITCH is placed in the ON position, the AC control circuit (2 & 6) in the lamphouse will energize the power supply circuitry providing DC current to the igniter and bulb. The green "GO" light on the xenon power supply indicates a completed circuit.

THERE WILL BE a distinctly audible high voltage arc ping at the igniter arc gap and across the bulb electrodes. The bulb should ignite immediately after one or two of these high voltage pulses, and the lamp current will adjust to the output setting of the xenon power supply. Multiple ignition pulses prior to bulb ignition normally indicate a low DC output setting; increase output to the 4 kW bulb's initial current setting (125 A.); see xenon power supply manual. A "warm" or aged xenon bulb might also require multiple strikes.

TROUBLE SHOOTING

IF THE XENON BULB does not ignite, observe the following operational sequences for assistance in locating and isolating the trouble area.

WHEN THE FANS and the indicator light on the power supply are on, the circuit in the power supply is trouble-free up to the terminal block in the power supply. At this time, the spotlight blowers should operate. If this does not occur, the trouble is in one of the blower motors, a loose connection, or a broken #7 or #8 lead (220 V.AC). Check at this time for 220 V.AC blower voltage at wires 7 & 8, and 220 V.AC at the lamphouse quick-disconnect pins 9 & 10. CAUTION: exercise extreme caution when taking voltage measurements in a power ON condition.

A DEFECTIVE DIGITAL DISPLAY will **not** prevent bulb ignition.

IF THE HIGH VOLTAGE PING or the ignition flash is not apparent, check voltages on the terminal board behind the display. A reading of 120-170 V.DC "no load" should be measured between #6 and #7, and 115 V.AC between #9 and #10. If these voltages are not indicated, the problem is in the leads between the lamphouse and power supply, or in the power supply boost circuit. See the trouble shooting section of the power supply manual for additional instructions.

THE SWITCHING-TYPE XENON POWER SUPPLY furnished with the spotlight system includes thermal overload switches and protection circuits to prevent damage resulting from high or low input voltage. Loss of DC open circuit voltage, or an interruption of DC sustaining current, may be traced to these circuits. See the power supply manual.

IF THE HIGH VOLTAGE ARC is audible at the lamphouse and the bulb does *not* flash, check for a lamphouse DC lead arcing to ground. If no ground fault is detected, replace the bulb and attempt ignition with the new bulb.

IF THE HIGH VOLTAGE ARC is audible at the lamphouse, the flash of the bulb is apparent, but ignition of the bulb is not sustained, the problem area is in the power supply. See the trouble shooting section of the power supply manual for additional instructions.

IF THE HIGH VOLTAGE ARC is *not* audible or the flash of the bulb visible, the problem is in the igniter assembly.

EXCHANGE of components (i.e. igniters, printed circuit boards) between similar Strong Xenon Gladiators to aid in diagnosis of a problem is encouraged. This will not lead to equipment damage, and will not void equipment warranty.

XENON GLADIATOR IV TROUBLESHOOTING



EXERCISE ALL DUE CAUTION WHEN MEASURING
VOLTAGES IN A "POWER ON" CONDITION



Bulb fails to ignite.

1. AC power not on to lamphouse. Turn switching power supply 30 A. circuit breaker ON. If 230 V.AC not read at 1 & 2, or POWER indicator not glowing, see power supply manual.
2. Faulty "ON-OFF" switch. Check for voltage at terminal block positions 9 & 10; check for loose terminals or wiring. Replace if defective.
3. Low AC source voltage actuating "brownout" protection circuit in xenon power supply.

Bulb fails to ignite; ping audible, bulb flash visible.

1. Inadequate DC output from xenon power supply. Set power supply output to correct range required for bulb wattage (120-150 A. for 4000 watt). Do not exceed 150 A.
2. If bulb flash is visible but faint, check for defective printed circuit board in igniter. Replace if defective.
3. Faulty or expired xenon bulb. Replace as required.

Bulb fails to ignite; ping audible, no bulb flash.

1. Faulty xenon bulb. Check for cracked electrodes or darkened envelope. Replace if defective.
2. Ignition pulse shorting to ground. Inspect DC leads for burned insulation; dress leads away from grounded metal components.

No high voltage ping audible; LAMP switch in "ON."

1. Loss of AC control voltage. Check xenon power supply for tripped circuit breaker or open thermal switch. See power supply manual.
2. Lamphouse top cover interlock switch open. Top cover must be closed and both latches secured.
3. Xenon power supply "GO" light not glowing. See power supply manual.
4. Little or no DC "No Load" voltage. Measure DC "No Load" voltage at 6 & 7. See power supply manual.
5. Open fuse F1 (10 A.) on switching power supply primary PC board. SEE POWER SUPPLY MANUAL. Allow (20) minutes for capacitor discharge before replacing.
6. Loose spark gap connections or terminals. Repair or replace igniter PC board as required.

Digital Display not ON.

1. Check for loose connection on plug J5.
2. Check for 230 V.AC on terminal block positions 1 & 2. If correct, check X1 transformer output for 115 V.AC. If not measured, replace transformer.

Bulb goes out during operation.

1. Xenon power supply overheated; thermal switch open. Check power supply blower(s), air inlets and outlets unobstructed. See power supply manual.
2. Xenon bulb depressurizing. Check for envelope discoloration; replace if defective.
3. Fluctuating AC source voltage actuating brownout or spike protection circuits in xenon power supply. See power supply manual.
4. Lamphouse cover loose or open. Close and secure.

Noise in theatre sound as bulb ignites.

1. Faulty RF suppression capacitor(s). Remove and test C1. Replace if defective.
2. Lamphouse, power supply, or sound system not properly grounded. Connect to adequate earth ground.

Excessive light flicker..

1. Faulty or aged bulb. Check for cracked or sagging electrodes; replace if defective.
2. Excessive ripple in DC output. See power supply manual.
3. Arc stabilization magnet reversed. NORTH pole should point toward operator's side. Check with compass if required.

Reduced light output.

1. Normal bulb aging. Increase output current. DO NOT EXCEED MAXIMUM CURRENT LEVEL SPECIFIED BY BULB MANUFACTURER.
2. Soiled reflector. Clean using commercial glass cleaner; USE NO ABRASIVES.
3. Soiled heat filter, projection lens, or large lens. Clean as required.
4. Bulb or reflector position altered. Correct alignment; see preceding OPERATION section.

Extremely long duration between ignition pulses.

1. Low DC "no load" voltage from the xenon power supply. Check "no load" voltage; see power supply manual.
2. Defective spark gap. A "Ping" sound is normal; excessive "Hissing" is abnormal. Replace if defective.

Colors burning or fading prematurely.

1. Bulb focused to "hot spot." Refocus bulb to flat field with iris fully open and spot size control handle ("trombone") fully forward.
2. Heat filter glass reversed or peeled. Check for *coated* surface *toward bulb*; replace if coating peeled.
3. Reflector coating peeled. Replace if defective.

FIGURE 1

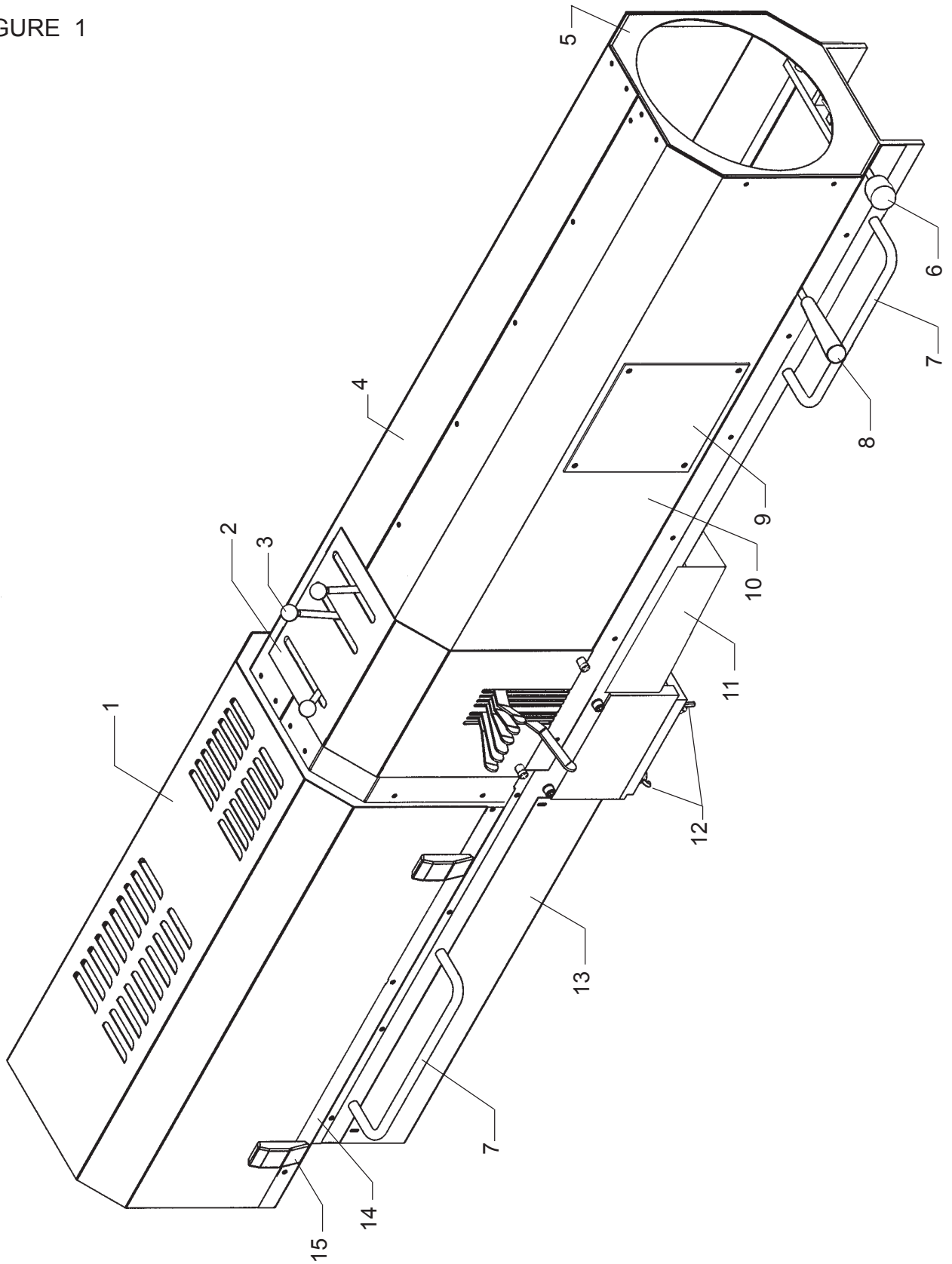

PARTS LIST

Figure 1

<u>Item</u>	<u>Part No.</u>	<u>Description</u>
1	72-00164	Lamphouse Top Cover & Access Panel
-	72-00163	Side Cover, Off-Operator Side (not shown)
2	72-00247	Cover Plate, Optical System Controls
3	10048A00	Knob
4	72-00207	Lens System Cover, Off-Operator Side
5	72-00175	Front Cover, Lens System
6	25064000	Lens Focus Knob
7	25221000	Hand Rail
-	4310751	Mounting Screw, 5/16-18 x 3/4"
-	4317000	Lockwasher, 5/16"
8	51509000	Handle, Spot Size Control
9	72-00246	Access Panel
-	31-98209	Quarter-Turn Fastener (4 req'd.)
-	31-98200	Receptacle, Quarter-Turn Fastener (not shown)
10	72-00206	Lens System Cover, Operator Side
11	72-00397	Bottom Cover, Front
12	4310753	Wing Screw, 5/16-18 (4 req'd.)
-	4317100	Washer, 5/16" (4 req'd.)
13	72-00170	Bottom Cover, Rear
14	72-00162	Lower Cover, Lamphouse Access
15	31-18007	Clasp Latch (2 req'd.)

FIGURE 2

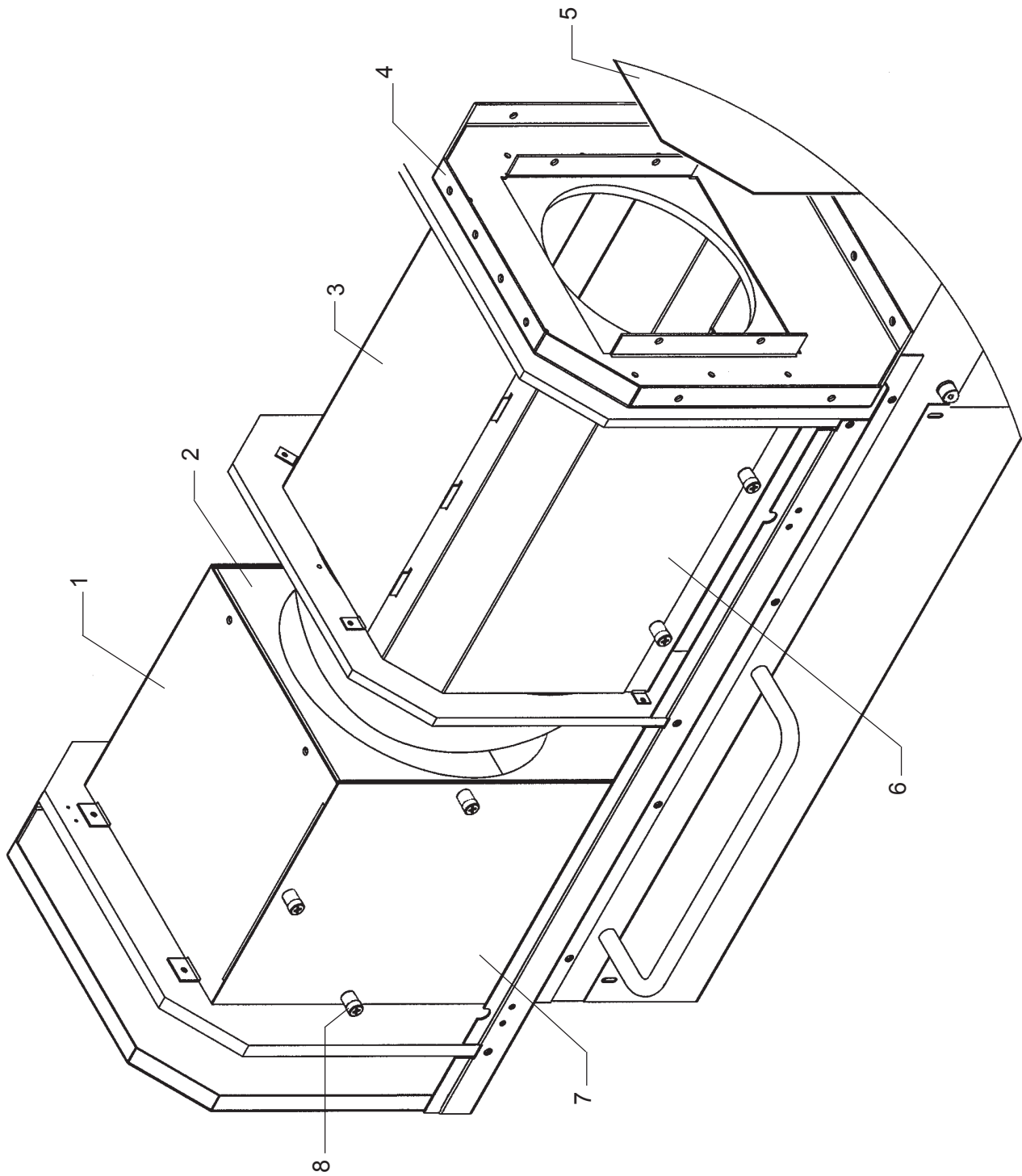

PARTS LIST

Figure 2

<u>Item</u>	<u>Part No.</u>	<u>Description</u>
1	72-00160	Bulb Enclosure Top Cover, Rear
2	72-00159	Bulb Enclosure Brace
-	00M15315	Arc Stabilization Magnet (not shown)
-	81137000	Magnet Clamp
-	4080259	Set Screw, 8-32 x 1/4"
3	72-00166	Bulb Enclosure Top Cover, Front
4	72-00173	Mounting Bracket, Fade Out Assembly
5	72-00258	Light Shield (see Figure 3, Item 14)
6	72-00167	Access Panel, Front
7	72-00161	Access Panel, Rear
8	31-98209	Quarter-Turn Fastener (5 req'd.)
-	31-98200	Receptacle, Quarter-Turn Fastener (not shown)

BULB MOUNTING COMPONENTS

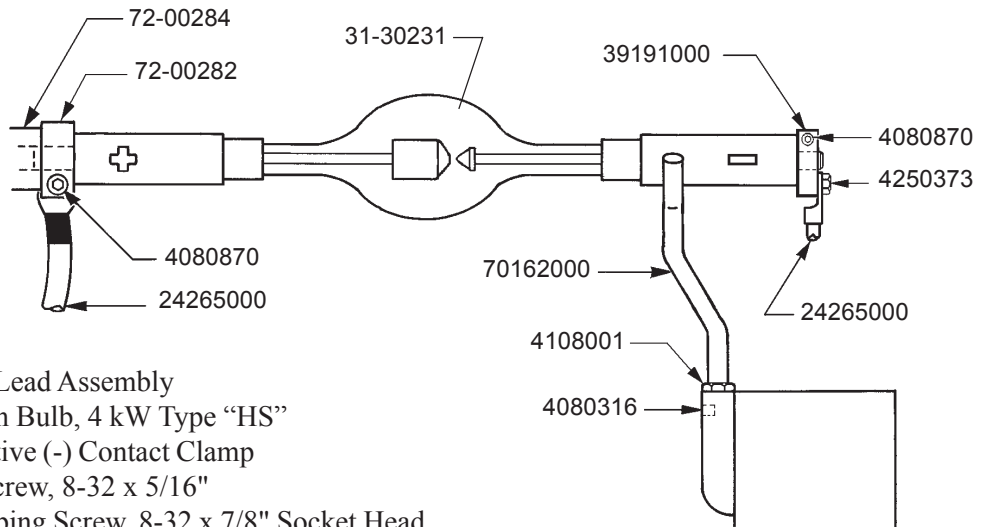

24265000	Bulb Lead Assembly
31-30231	Xenon Bulb, 4 kW Type "HS"
39191000	Negative (-) Contact Clamp
4080316	Set Screw, 8-32 x 5/16"
4080870	Clamping Screw, 8-32 x 7/8" Socket Head
4108001	Height Adjust Lock Nut, 10-32 Hex
4250373	Screw, 1/4-20 x 3/8" Hex Head
70162000	Front Bulb Support Yoke (see Figure 3, Item 48)
72-00282	Positive (+) Contact Clamp
72-00284	Rear Bulb Support Collet (see Figure 3, Item 53)

FIGURE 3

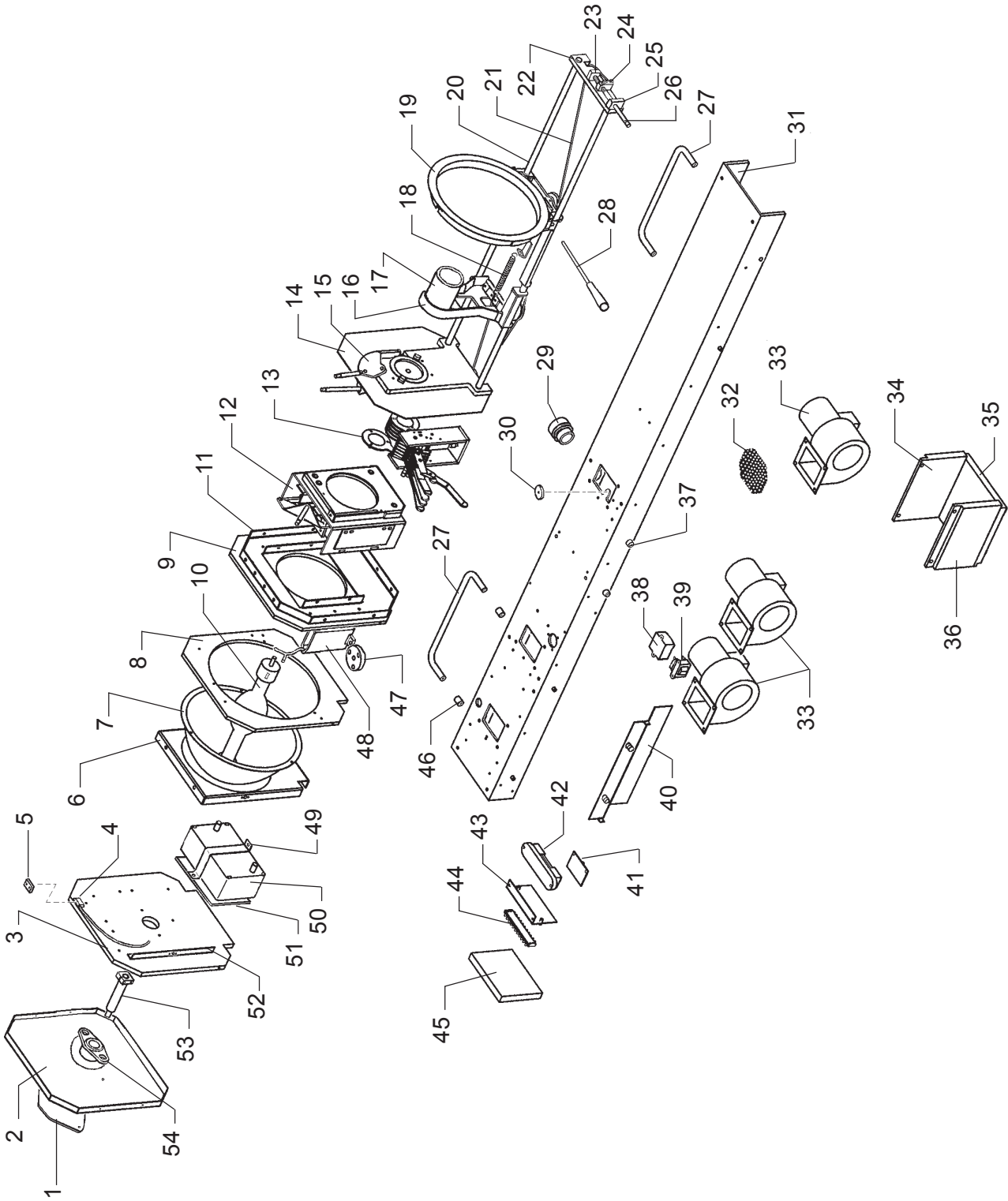

PARTS LIST

Figure 3

<u>Item</u>	<u>Part No.</u>	<u>Description</u>
1	72-00658	Access Cover Plate
-	4100504	Mounting Screw, 10-32 x 1/2"
-	31875000	Thumbscrew, 10-32
2	72-00158	Lamphouse Back Cover
3	72-00155	Rear Lamphouse Bulkhead Plate
-	4250752	Mounting Screw, 1/4-20 x 3/4"
-	4257000	Lockwasher, 1/4"
4	21-98544	Interlock Switch & Lead Assembly
-	4040500	Mounting Screw, 4-40 x 1/2"
5	21-61007	Magnet, Switch Actuator (mounts to Figure 1, Item 1)
6	72-00159	Bulb Enclosure Brace (see Figure 2, Item 2)
-	00M15315	Arc Stabilization Magnet (not shown)
-	81137000	Magnet Clamp
-	4080259	Set Screw, 8-32 x 1/4"
7	25361000	Flanged Reflector, 12.8" Diameter
-	4081504	Mounting Screw, 8-32 x 1-1/2" (3 req'd.)
-	21-58040	Compression Spring (3 req'd.)
-	4088002	Cap Nut, 8-32 (3 req'd.)
8	72-00156	Reflector Bulkhead Plate
-	4250752	Mounting Screw, 1/4-20 x 3/4"
-	4257000	Lockwasher, 1/4"
9	72-00157	Front Lamphouse Bulkhead Plate
-	4250752	Mounting Screw, 1/4-20 x 1/2"
-	4257000	Lockwasher, 1/4"
10	31-30231	Xenon Bulb, 4 kW Type "HS"
11	72-00173	Support Bracket, Fade Out Assembly
-	4080375	Mounting Screw, 8-32 x 3/8" Pan Head
12	72-00261	Fade Out & Heat Filter Assembly (see Figure 4)
-	4250752	Mounting Screw, 1/4-20 x 3/4"
-	4258007	Hexnut, 1/4-20
-	4257102	Washer, 1/4"
13	72-00264	Color Boomerang Assembly (see Figure 5)
14	72-00258	Light Shield
15	72-00257	Iris & Chopper Assembly (see Figure 6)
-	4250752	Mounting Screw, 1/4-20 x 3/4"
-	4257000	Lockwasher, 1/4"
16	72-00289	Small Lens Carriage
17	83144000	Lens Barrel
-	4080371	Mounting Screw, 8-32 x 3/8" Flat Head (3 req'd.)
-	44239A00	Projection Lens (Buhl), before March 2004
-	44239C00	Projection Lens (ISCO), after March 2004
-	83155000	Lens Retaining Clip (2 req'd.)
18	51162000	Expansion Spring
-	51120000	Spring Retaining Bracket

PARTS LIST, Figure 3 (continued)

<u>Item</u>	<u>Part No.</u>	<u>Description</u>
19	51914000	Large Lens Ring
-	4110371	Mounting Screw, 10-24 x 3/8" Fillister Head (6 req'd.)
-	51408000	Large Lens
-	51417000	Lens Retainer
-	51350000	Large Lens Carriage
-	25088000	Large Pulley
-	51160000	Pulley Axle, Shoulder Bolt
20	70-00202	Slide Rod (2 req'd.)
-	51114000	Stop Collar
-	51479000	Collar Bushing, Rubber
21	21-71187	Cable, Lens Focus (Order 4.5 ft.)
22	72-00203	End Bracket, Slide Rods
23	72-00205	Inner Bearing Block
24	72-00321	Lens Focus Block
-	25069000	Cable Clamping Plate
-	4080502	Mounting Screw, 8-32 x 1/2" Socket Head
25	72-00204	Outer Bearing Block
26	72-00214	Lens Focus Shaft
27	25221000	Hand Rail
-	4310751	Mounting Screw, 5/16-18 x 3/4"
-	4311750	Mounting Screw, 5/16-18 x 1-3/4" (with Item 46)
-	4317000	Lockwasher, 5/16"
28	51441000	Shaft, Spot Size Handle
-	51428000	Retaining Ring
-	51509000	Handle
29	61-98039	Bushing, Xenon Power Supply Cable
-	72-00251	Interconnect Cable Assembly, Lamphouse/Power Supply (Figure 8)
30	25089000	Small Pulley (2 req'd.)
-	51160000	Shoulder Bolt, Pulley Axle
31	72-00168	Base Channel
32	72-00286	Grille, Blower Outlet (3 req'd.)
33	81-33026	Blower, 230 V.AC, 50/60 Hz. (B1,B2,B3)
-	4250373	Mounting Screw, 1/4-20 x 3/8" Hex Head
-	4257000	Lockwasher, 1/4"
34	72-00278	Base Adapter, Left
35	25223000	Base Adapter, Center
36	72-00279	Base Adapter, Right
-	4311000	Assembly Screw, 5/16-18 x 1 Socket Head
37	4370754	Adapter Mounting Screw, 3/8-16 x 3/4" Socket Head (4 req'd.)
38	72-00255	Filter Capacitor & Leads Assembly (C1)
-	4080250	Mounting Screw, 8-32 x 1/4" Pan Head
39	72-00253	Transformer & Leads Assembly (X1)
-	4080250	Mounting Screw, 8-32 x 1/4" Pan Head

PARTS LIST, Figure 3 (continued)

<u>Item</u>	<u>Part No.</u>	<u>Description</u>
40	72-00165	Bulb Enclosure Panel, Lower (2 req'd.)
41	24275000	Voltage Divider PC Board Assembly
42	81247000	Shunt (R1), 200 A. 50 mV.
-	4080754	Mounting Screw, 8-32 x 3/4" Pan Head
43	72-00209	Mounting Bracket, Terminal Board
-	4080250	Mounting Screw, 8-32 x 1/4" Pan Head
44	72-00252	Terminal Board & Molex Wired Assembly
-	4080506	Mounting Screw, 8-32 x 1/2" Pan Head
45	25098000	Digital Meter Board Assembly
-	72-00171	Cover Panel (not shown)
46	72-00213	Spacer, Hand Rail (2 req'd.)
-	4311750	Mounting Screw, 5/16-18 x 1-3/4"
47	81301000	Insulator, Negative Binding Post
-	4080506	Mounting Screw, 8-32 x 1/2" Pan Head
-	81300000	Binding Post, 3/8-16 Brass (with 72-00251 Assembly)
-	4378003	Hexnut, 3/8-16 Brass
-	4377000	Lockwasher, 3/8"
48	40107000	Air Duct Casting
-	4250503	Duct Mounting Screw, 1/4-20 x 1/2" Hex Head
-	72-00287	Insulator Spacer Plate
-	4250752	Insulator Mounting Screw, 1/4-20 x 3/4" Hex Head
-	70162000	Bulb Yoke
-	4080316	Yoke Set Screw, 8-32 x 5/16"
49	72-00169	Retaining Strap, Igniter
-	4080375	Mounting Screw, 8-32 x 3/8" Pan Head
50	39862000	DC Pulse Igniter Assembly
51	72-00395	Insulator Plate
52	72-00160	Mounting Bracket, Bulb Enclosure (2 req'd.)
-	4080375	Mounting Screw, 8-32 x 3/8" Pan Head
53	72-00284	Rear Bulb Support Collet
-	72-00282	Positive Clamp
54	65827000	Bulb Adjustment Assembly

65827000 Bulb Adjustment Assembly

- 21-48027 Snap Ring, Collet Retaining
- 72-00284 Collet
- 37985000 Thumb Screw (2 req'd.)
- 15010000 Compression Spring (2 req'd.)
- 65116000 Casting, Adjustment Mechanism
- 65150000 Fender Washer (2 req'd.)
- 65153000 Focus Lockscrew
- 65154000 Nylon Locking Ball
- 65959000 Focus Screw & Bearing Assembly

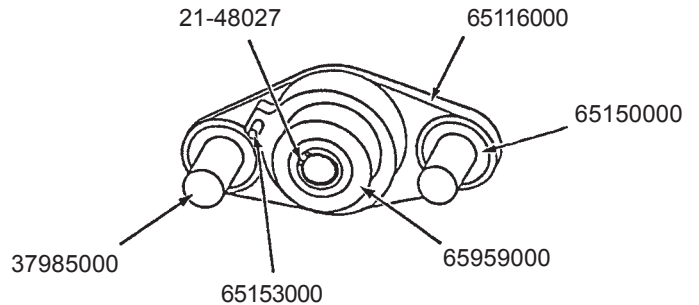

Fade Out & Heat Filter Assembly

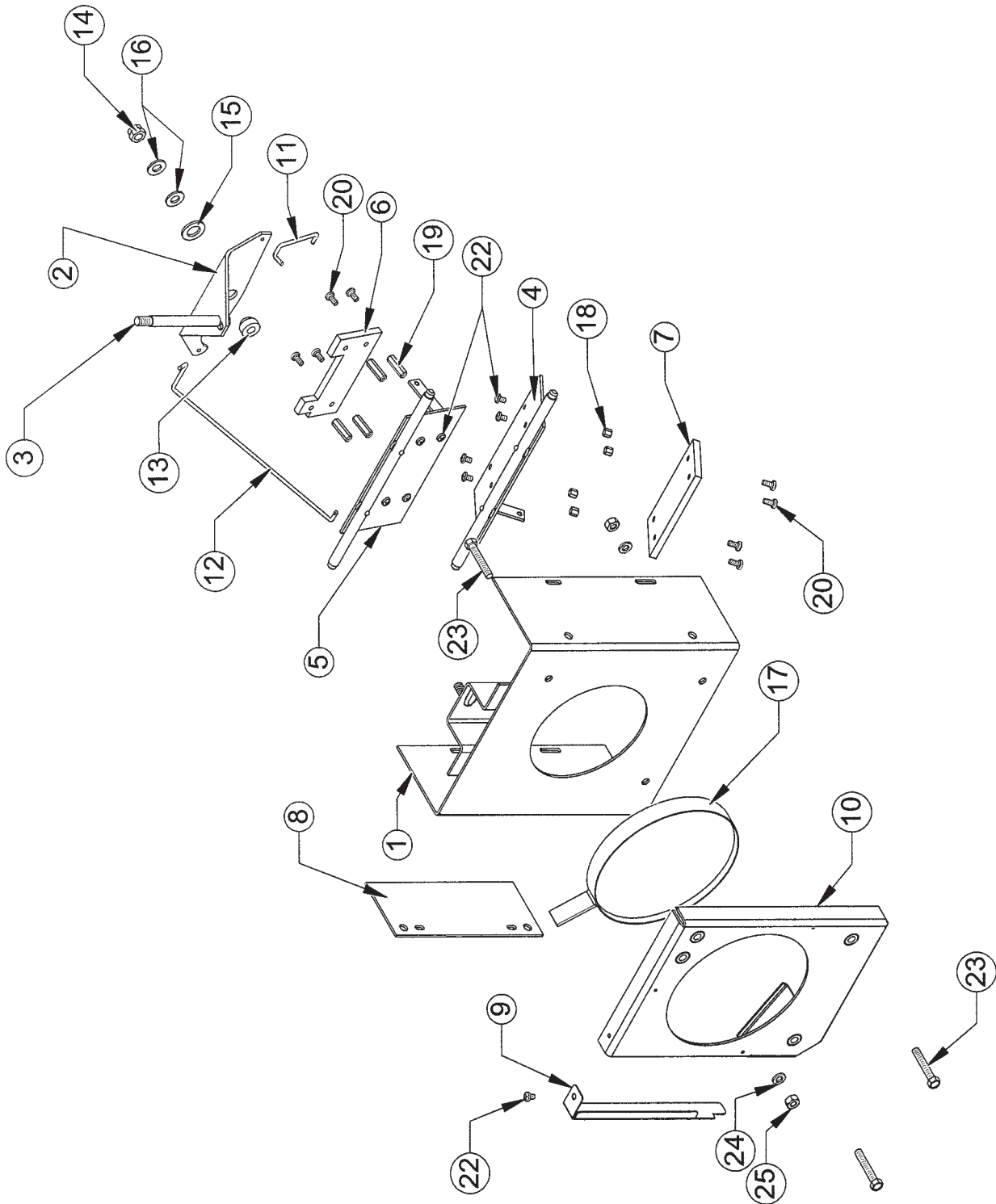

FIGURE 4

PARTS LIST

Figure 4

<u>Item</u>	<u>Part No.</u>	<u>Description</u>
1	72-00212	Fade Out Housing, Welded Assembly
2	72-00262	Bell Crank, Fade Out Dousers
3	51155000	Control Lever, Fade Out
-	4257102	Flatwasher, 1/4" SAE
-	4258001	Hexnut, 1/4-20
4	72-00268	Lower Douser Blade Assembly
5	72-00265	Upper Douser Blade Assembly
6	72-00272	Heat Shield, Upper Blade
7	72-00271	Heat Shield, Lower Blade
8	83351000	Pivot Adjusting Plate, Douser Blades
-	4100503	Mounting Screw, 10-32 x 1/2"
9	24332000	Cover Shield, Heat Filter
10	81847000	Heat Filter Holder, Welded Assembly
11	72-00273	Pull Rod, Short
12	72-00274	Pull Rod, Long
-	01704000	Hitch Pin, Pull Rods (not shown; 4 req'd.)
13	51153000	Spacer Bushing
14	4318004	Lock Nut, 5/16-18 Hex
15	4507106	Washer, 1/2" Brass
16	4317102	Washer, 5/16" SAE (2 req'd.)
17	72-00504	Heat Filter & Ring Assembly
18	41-98003	Stand-Off, 1/4" Hex (4 req'd.)
19	51-56016	Stand-Off, 7/8" (4 req'd.)
20	4080375	Mounting Screw, 8-32 x 3/8" Pan Head
22	4080250	Mounting Screw, 8-32 x 1/4" Pan Head
23	4251500	Mounting Screw, 1/4-20 x 1-1/2" Hex Head (3 req'd.)
24	4257001	Lockwasher, 1/4"
25	4258001	Hexnut, 1/4-20

FIGURE 5A

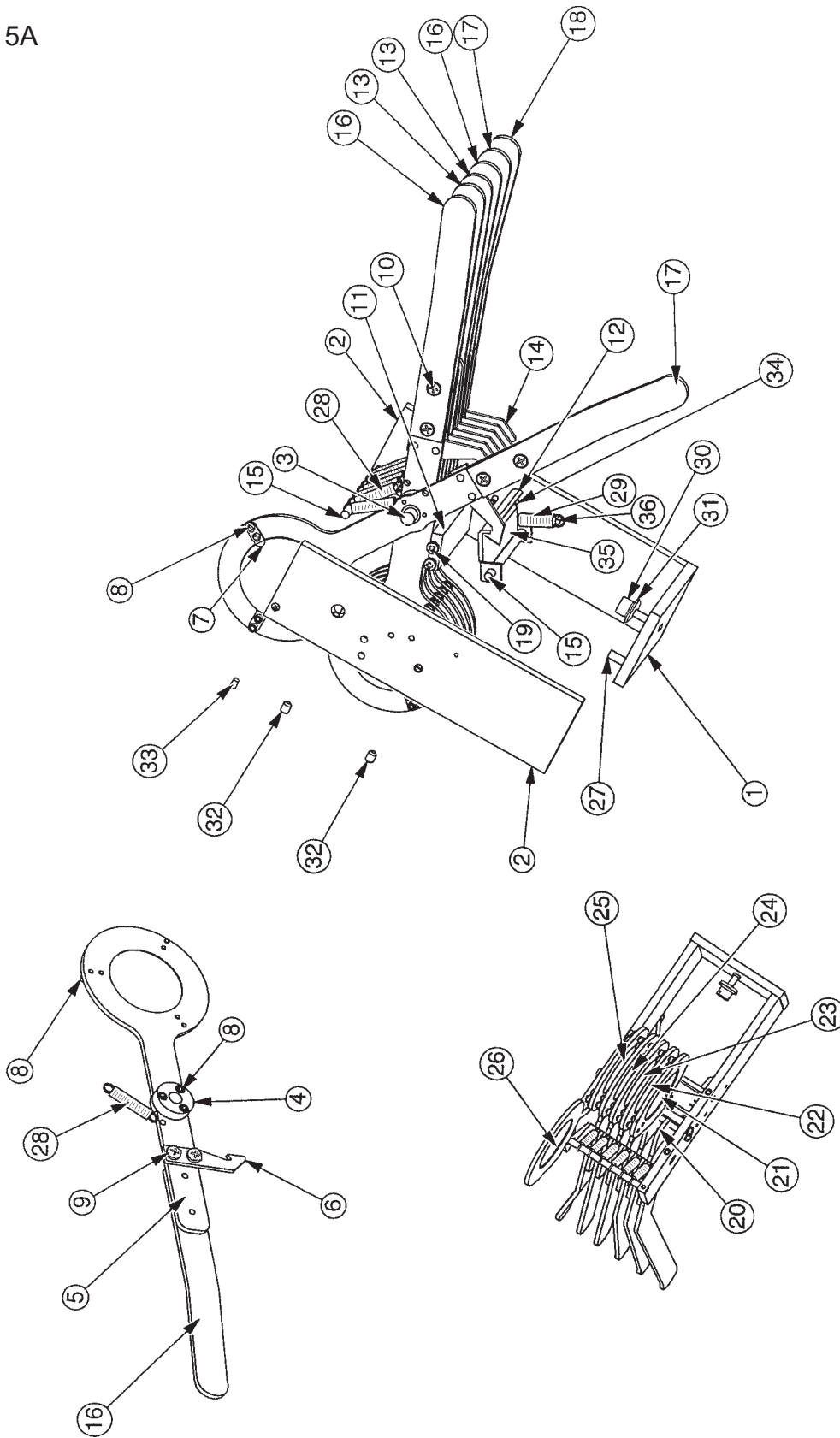

Color Boomerang
Assembly No. 72-00264

PARTS LIST

Figure 5A

<u>Item</u>	<u>Part No.</u>	<u>Description</u>
1	72-00196	Bottom Plate
2	72-00195	Side Plate (2 req'd.)
3	72-00186	Pivot Rod
4	72-00176	Bronze Bearing (7 req'd.)
5	72-00181	Color Holder (6 req'd.)
6	51396000	Color Holder Catch Hook (6 req'd.)
7	72-00260	Retainer Clip (18 req'd.)
8	4040252	Screw, 4-40 x 1/4" Socket Head
9	4080250	Screw, 8-32 x 1/4" Pan Head
10	4080255	Screw, 8-32 x 1/4" Flat Head
11	72-00177	Stop Plate
12	72-00194	Color Arm Catch Plate
13	72-00180	Color Arm, 0° (2 req'd.)
14	72-00183	Color Arm Release
15	72-00185	Spring Pivot Rod
16	72-00179	Color Arm, 10° (2 req'd.)
17	72-00178	Color Arm, 20° (2 req'd.)
18	72-00184	Color Arm, 30°
19	4060500	Screw, 6-32 x 1/2" Pan Head
20	72-00259	Release Arm
21	71-98011	Dichroic Filter, Flame Red
22	71-98014	Dichroic Filter, Lavender
23	71-98012	Dichroic Filter, Wheat Yellow
24	71-98012	Dichroic Filter, Jade Green
25	71-98010	Dichroic Filter, Navy Blue
26	71-98009	Dichroic Filter, Magenta Purple
27	4100623	Screw, 10-32 x 5/8" Flat Head
28	51-58018	Expansion Spring (7 req'd.)
29	21-58011	Expansion Spring
30	72-00657	Captive Screw
31	4257106	Seal Washer, Neoprene (as req'd.)
32	4100252	Set Screw, 10-32 x 1/4"
33	4060256	Set Screw, 6-32 x 1/4"
34	21-37033	Roll Pin, 1/8" Dia. x 5/8"
35	51505000	Bumper Pad (NOTE: Cut to fit)
36	82-20385	Spring Stud, Threaded 4-40

Additional 50mm dichroic color filters available through most theatrical supply dealers.

FIGURE 5B

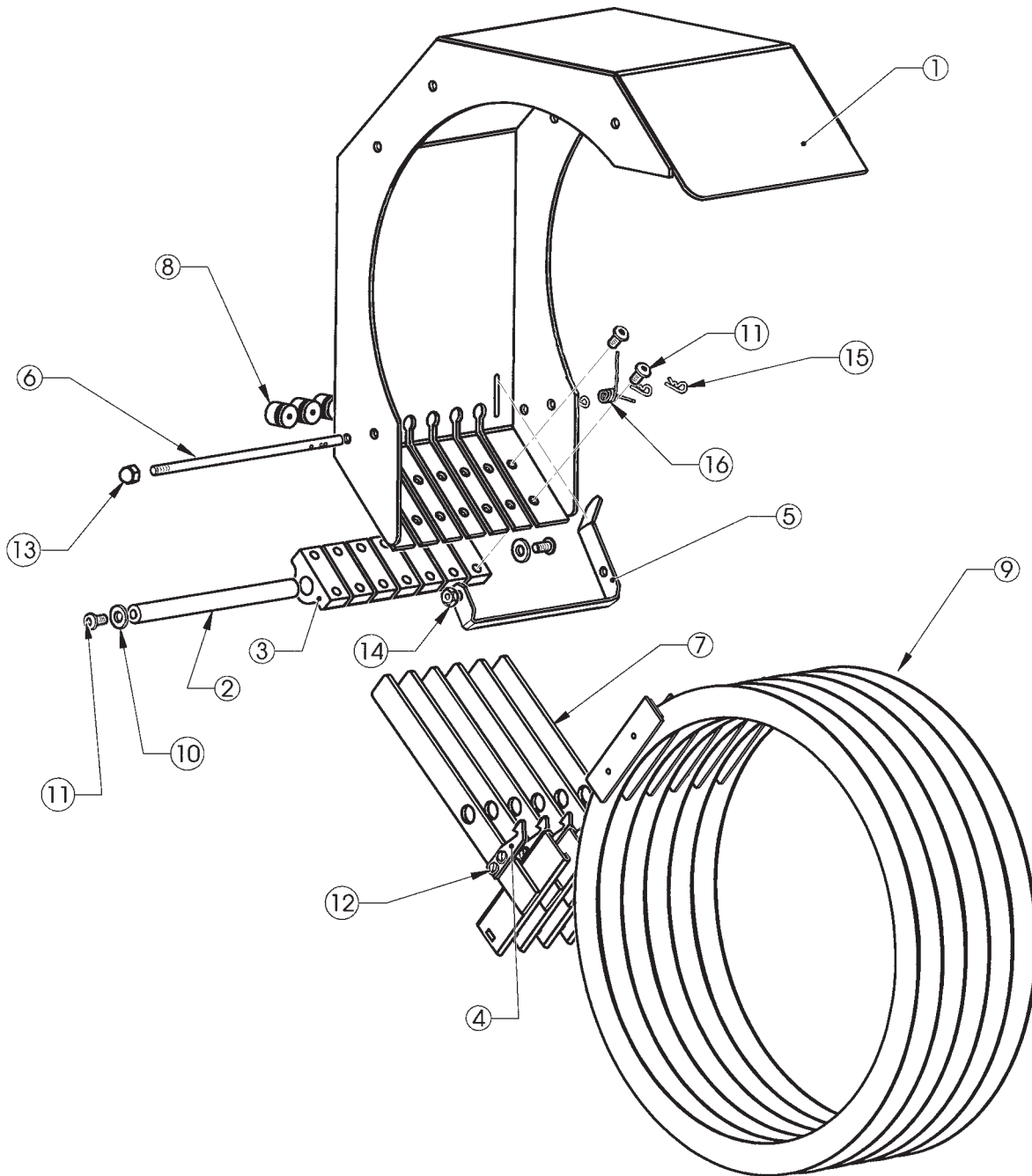

Color Boomerang
Assembly No. 72-00709

PARTS LIST

Figure 5B

<u>Item</u>	<u>Part No.</u>	<u>Description</u>
1	72-00710	Shroud Assembly
2	72-00714	Pivot Shaft
3	72-00713	Bearing Block (7 req'd.)
4	51396000	Color Holder Catch Hook (6 req'd.)
5	72-00715	Lock & Release Lever
6	72-00716	Lock/Release Lever Shaft
7	72-00721	Color Arm Assembly (6 req'd.)
8	71-58003	Rubber Bumper (6 req'd.)
9	72-00717	Gel Ring, 13½" Diameter; Welded Assembly (6 req'd.)
10	4257102	Flatwasher, 1/4" SAE (2 req'd.)
11	4250504	Screw, 1/4-20 x 1/2" Button Head (16 req'd.)
12	4080183	Screw, 8-32 x 3/16" (12 req'd.)
13	4268003	Acorn Nut, 1/4-28
14	2468006	Jam Nut, 1/4-28 Hex
15	01704000	Hitch Pin (3 req'd.)
16	71-58004	Torsion Spring

FIGURE 6

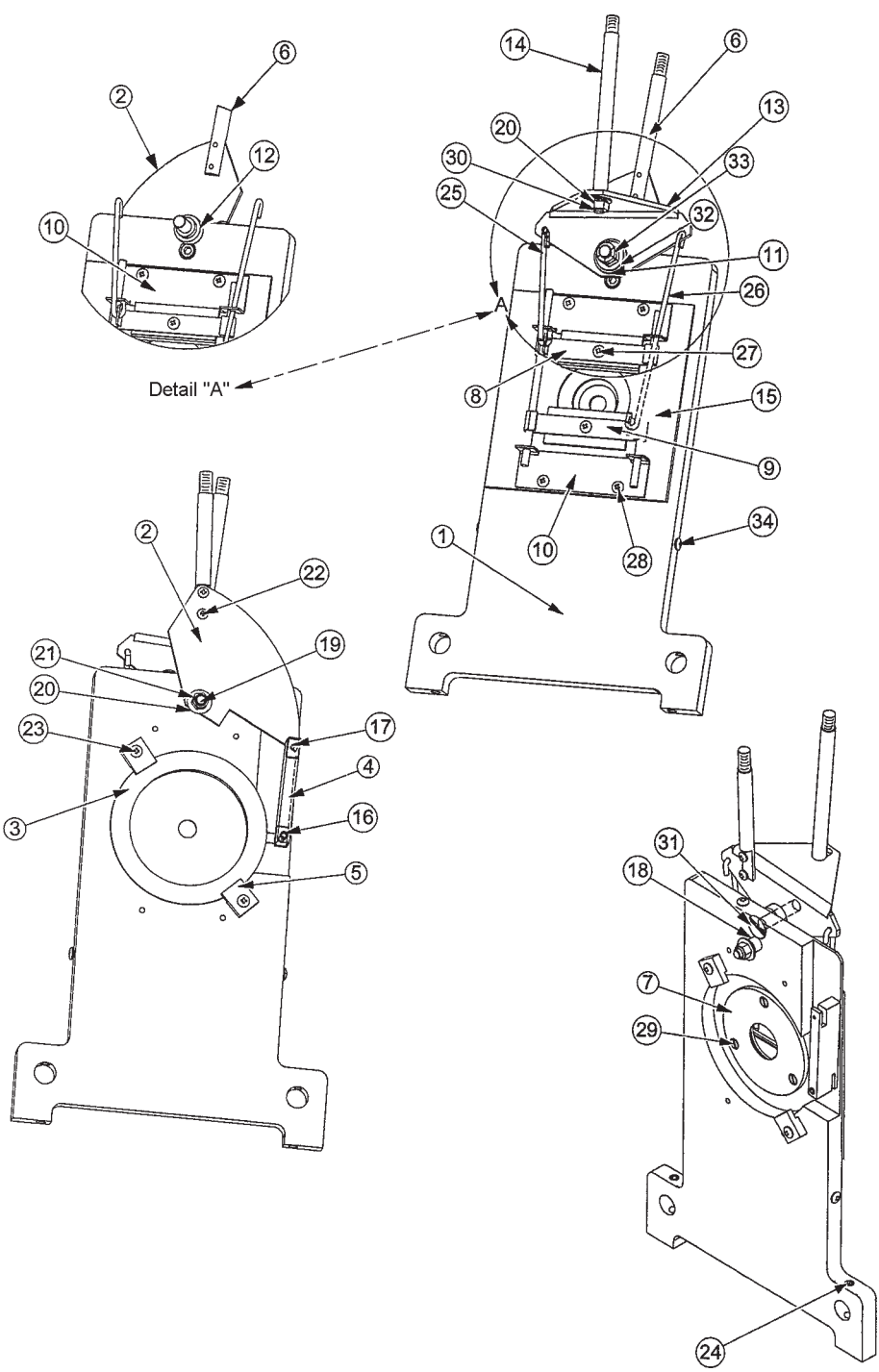

Iris, Chopper & Aperture Assembly

PARTS LIST

Figure 6

<u>Item</u>	<u>Part No.</u>	<u>Description</u>
1	72-00201	Iris Mount
2	72-00263	Iris Bell Crank
3	24374000	Iris
4	72-00075	Iris Linkage
5	72-00199	Iris Clamp (2 req'd.)
6	48402000	Iris Lever
-	4257002	Flatwasher, 1/4" SAE
-	4258001	Hexnut, 1/4-20
7	72-00200	Iris Back Plate
8	47972000	Upper Chopper Blade Assembly
9	47973000	Lower Chopper Blade Assembly
10	72-00197	Guide Plate (2 req'd.)
11	4507106	Washer, 1/2" Brass
12	51153000	Spacer Bushing, Chopper Blade
13	51520000	Bell Crank, Chopper Blades
14	51452000	Chopper Control Lever
15	72-00198	Gobo Holder
16	81432000	Shoulder Screw, 10-24
17	21-37011	Roll Pin, 3/32 x 9/16"
18	25017000	Shim Spacer
19	4251002	Screw, 1/4-20 x 1" Socket Head
20	4257102	Flatwasher, 1/4" SAE (2 req'd.)
21	51-35013	Stop Nut
22	4060250	Screw, 6-32 x 1/4" Pan Head (2 req'd.)
23	4080501	Screw, 8-32 x 1/2" Flat Head (2 req'd.)
24	4250251	Set Screw, 1/4-20 x 1/4" (2 req'd.)
25	72-00275	Chopper Blade Pull Rod, Short
26	72-00276	Chopper Blade Pull Rod, Long
27	4080181	Screw, 8-32 x 3/16" Pan Head (2 req'd.)
28	4080310	Screw, 8-32 x 5/16" Pan Head (4 req'd.)
29	4060252	Screw, 6-32 x 1/4" Flat Head (3 req'd.)
30	4258007	Stop Nut
31	4311251	Screw, 5-16-18 x 1-1/4" Flat Head
32	4317102	Flatwasher, 5/16" SAE
33	4318004	Hex Nut, 5-16-18 FlexLock
34	4080250	Screw, 8-32 x 1/4" Pan Head (3 req'd.)

FIGURE 7

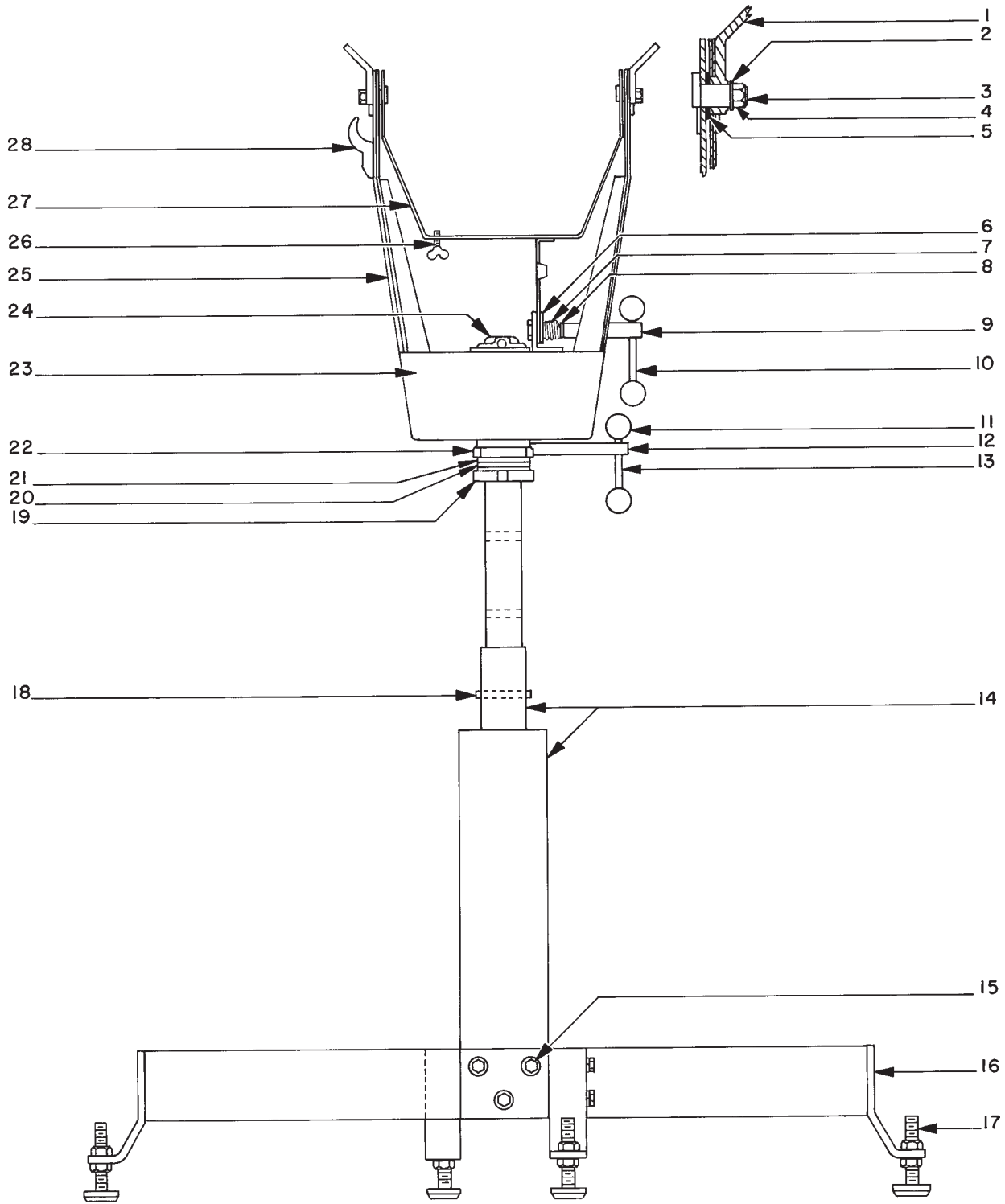

PARTS LIST

Figure 7

<u>Item</u>	<u>Part No.</u>	<u>Description</u>
1	49943000	Lifting Strap
2	4377102	Flatwasher, 3/8"
3	49120000	Tilt Axis Bolt
4	4378002	Locknut, 3/8-16 Hex
5	02411000	Washer, .640" I.D. x 1-1/4" O.D.
6	49126000	Clamp Plate
7	49125000	Compression Spring, Tilt Clamp
8	49124000	Spring Bushing
9	49223000	Clamp Shaft
10	49130000	Clamp Handle
11	10048A00	Knob, Round Plastic
12	49290000	Swivel Clamp Shaft
-	49291000	Stop Plate, Horizontal Swing
-	4872500	Bolt, 3/8-16 x 2-1/2" Square Head
13	49130000	Clamp Handle
14	72-00299	Base Column, Welded Assembly
15	4372750	Mounting Bolt, Base Leg; 3/8-16 x 2-3/4" Hex Head
-	4377001	Lockwasher, 3/8" Split Ring
16	83797000	Base Leg, Welded Assembly
-	47238000	Tandem Caster, Locking (not shown)
17	49226000	Leveling Foot
-	4508001	Locknut, 1/2-13 Hex
18	83294A00	Height Adjustment Pin
19	83794000	Tube & Collar Assembly
20	83113000	Needle Bearing
21	83114000	Race, Needle Bearing
22	49213000	Swivel Clamp Collar
-	4250503	Screw, 1/4-20 x 1/2" Hex Head
-	4257000	Lockwasher, 1/4" Split Ring
23	83357000	Yoke Cover Plate
-	4080375	Screw, 8-32 x 3/8" Pan Head
-	4087004	Lockwasher, #8 (as req'd.)
24	83112000	Collar, Inner Tube
-	4260370	Set Screw, 1/4-28 x 3/8" Dog Point
25	47951000	Yoke Assembly
26	4310753	Screw, 5/16-18 x 3/4" Wing Head
-	4317001	Lockwasher, 5/16"
-	4317102	Flatwasher, 5/16"
27	25236000	Saddle & Quadrant Assembly
28	83341000	Cable Clamp
-	4250623	Screw, 1/4-20 x 5/8" Hex Head
-	72-00299	Floor Stand Assembly (Items 1-28 Complete)

FIGURE 8

LAMPHOUSE CABLE ASSEMBLY
Part No. 72-00251

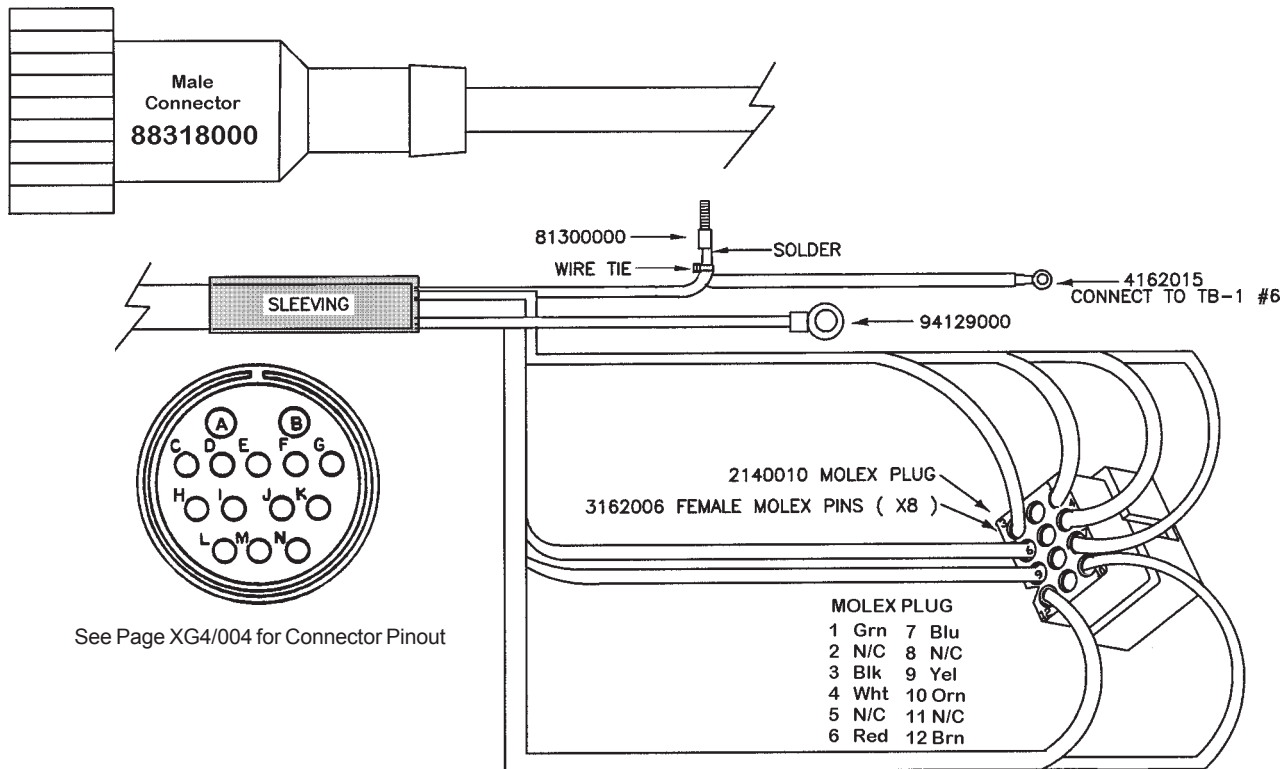

POWER SUPPLY CABLE ASSEMBLY
Part No. 62-70025

