

Automated Britelight®

MK5

Parts Catalog

Issue: June 2004



4350 McKinley Street • Omaha, Nebraska 68112 USA
Tel 402/453-4444 • Fax 402/453-7238 • www.strongint.com

Mark 5 Automated Britelight Parts Catalog

	<i>Page</i>
Figure 1	Final Assembly 1
Figure 2	Lamphead Frame & Reflector 2
Figure 3	Lamphead Bulkhead Assembly 4
Figure 4	Base Frame & Components 7
Figure 5	Pan Motor Assembly 9
Figure 6	Pan Drive Assembly 11
Figure 7	Motion Control Assembly 13
Figure 8	Auxiliary Power Supply 15
Figure 9	Base Housing 17
Figure 10	Yoke Assembly 19
Figure 11	Tilt Drive Assembly 21
Figure 12	Scroller/Douser Assembly 23
Figure 13	Xenon Power Supply 26

Strong Entertainment Lighting
4350 McKinley Street
Omaha, Nebraska 68112 USA
Tel 402/453-4444 • Fax 402/453-7238
www.strongint.com

FIGURE 1

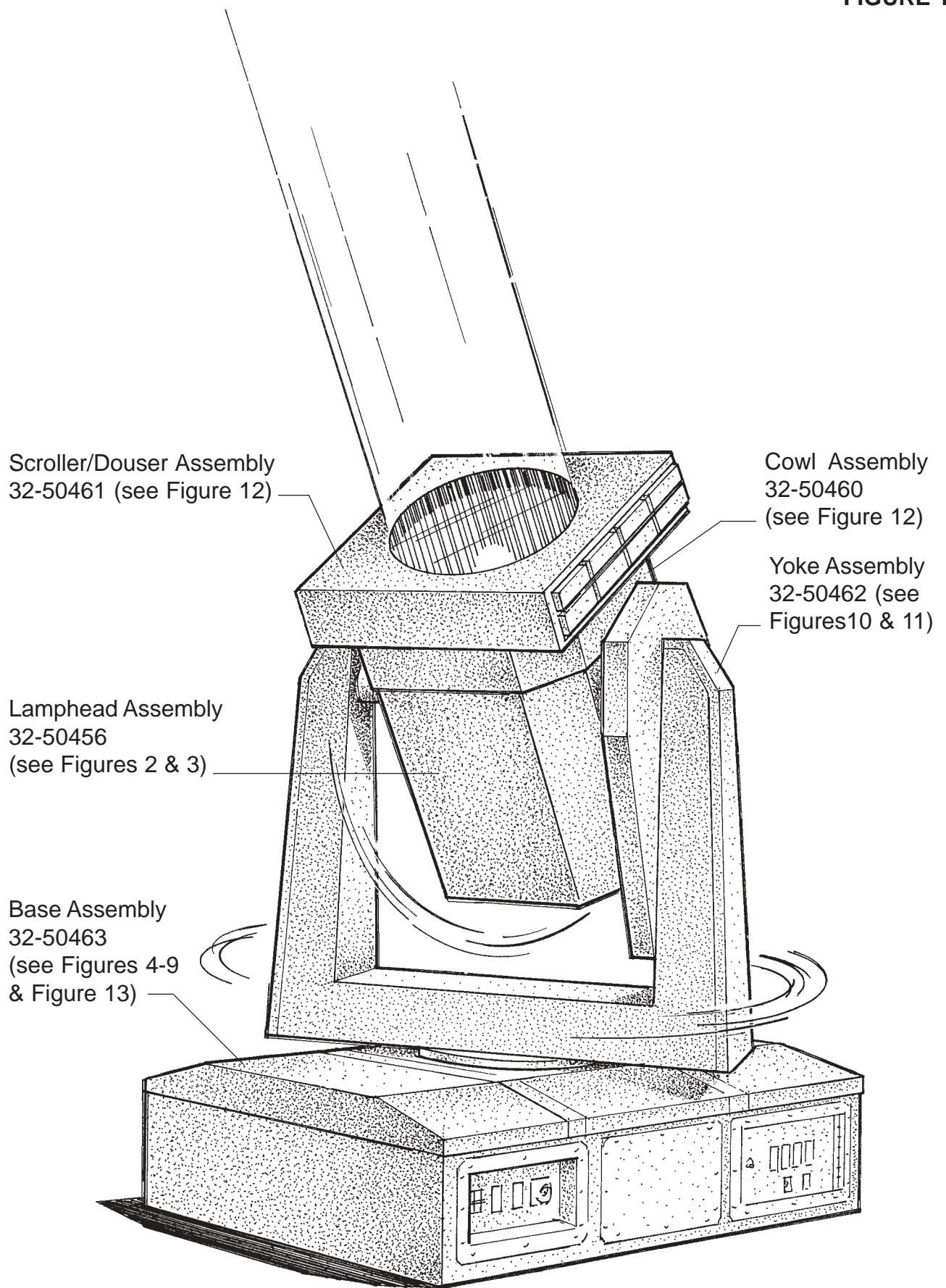
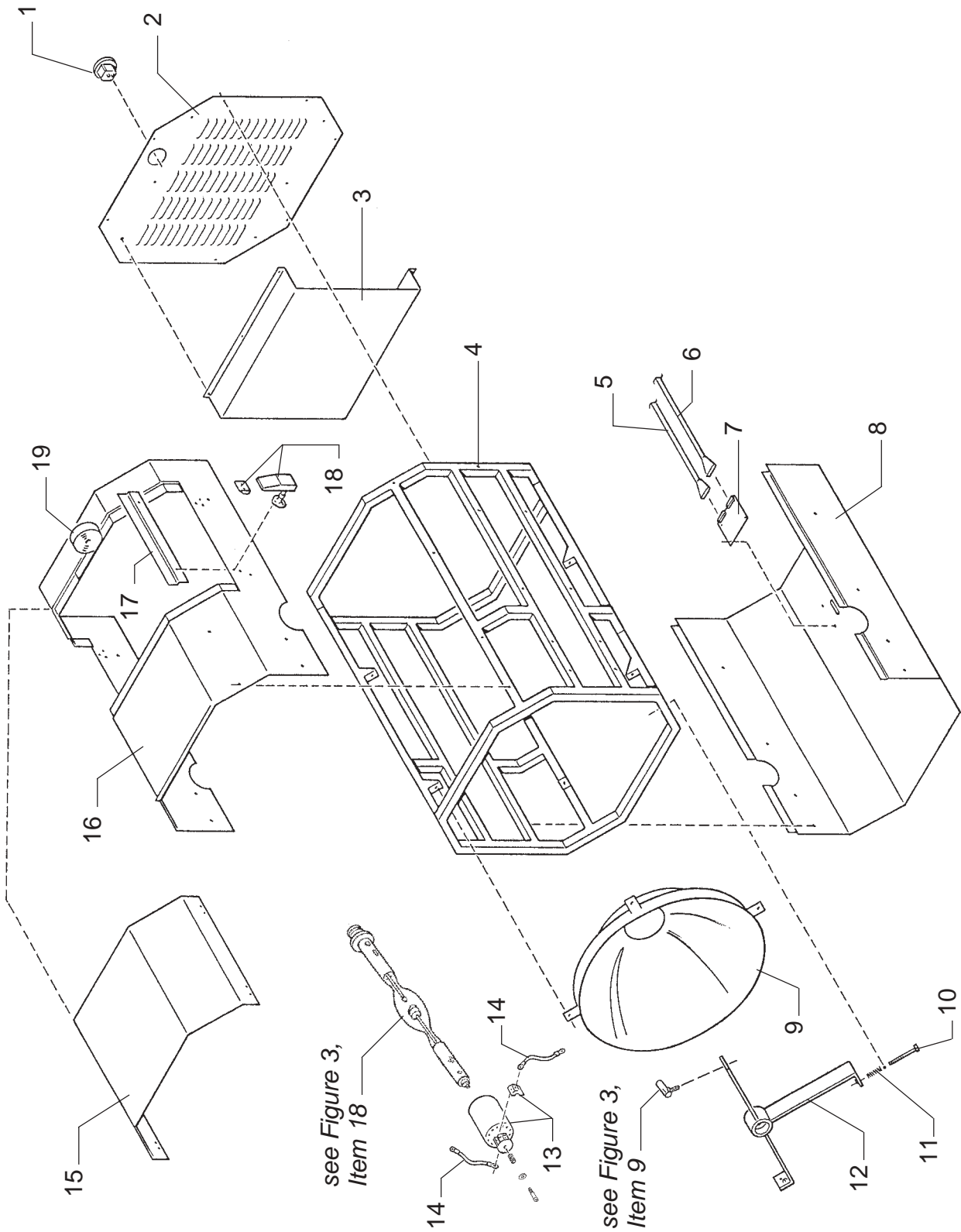

FIGURE 2



Lamphead Housing & Reflector

PARTS LIST

Figure 2

<u>Item</u>	<u>Part No.</u>	<u>Description</u>
1	31-32004	Hour Meter
2	32-40347	Lamphead Back Panel
-	4080370	Mounting Screw, 8-32 x 3/8" Pan Head, Black Oxide
3	32-40059	Heat Shield
-	4080370	Mounting Screw, 8-32 x 3/8" Pan Head, Black Oxide
4	32-40598	Lamphead Frame, Welded Assembly
5	32-70107	DMX Cable, Scroller
6	32-70108	DMX Cable, Douser
7	32-70142	PC Board, DMX Interface
-	4040180	Mounting Screw, 4-40 x 3/16" Pan Head
8	31-29275	Base Pan
-	4080370	Mounting Screw, 8-32 x 3/8" Pan Head, Black Oxide
9	32-50397	Reflector Assembly
-	4251003	Mounting Screw, 1/4-20 x 1" Hex Head
10	4102000	Screw, 10-32 x 2" Socket Head (2 req'd.)
11	31-58028	Compression Spring (2 req'd.)
12	32-40351	Front Bulb Support Bracket
-	31-61073	Thermal Switch, open at 300° F. (not shown)
-	4060250	Switch Mounting Screw, 6-32 x 1/4" Pan Head
-	4068001	Hexnut, 6-32
-	4250502	Positive Contact Screw, 1/4-20 x 1/2" Hex Head Brass (2 req'd.)
-	4257003	Lockwasher, 1/4" Bronze
-	4258003	Hexnut, Brass
13	32-50177	Radiation Shield & Anode Clamp Assembly
-	4100750	Clamping Screw, 10-32 x 3/4" Socket Head (with Item 13)
-	41-51767*	Shoulder Bolt, 5/16 x 3/4" 1/4-20 Thrd.
-	4317001*	Flatwasher, 5/16"
-	31-58005*	Compression Spring, .720" x .75"
14	32-50244	Anode Lead Assembly (2 req'd.)
15	31-18030	Top Access Cover
16	31-29178	Top Cover
-	4080370	Mounting Screw, 8-32 x 3/8" Pan Head, Black Oxide
17	---	Light Shield (Incl. with Item 16; 2 req'd.)
18	31-18007	Latch & Catch (4 req'd.)
-	4100503	Mounting Screw, 10-32 x 1/2" Pan Head
-	4108007	Hexnut, 10-32
19	31-98153	Weatherstripping Tape, Self-Adhesive

* Not included with Item 13; order separately

FIGURE 3

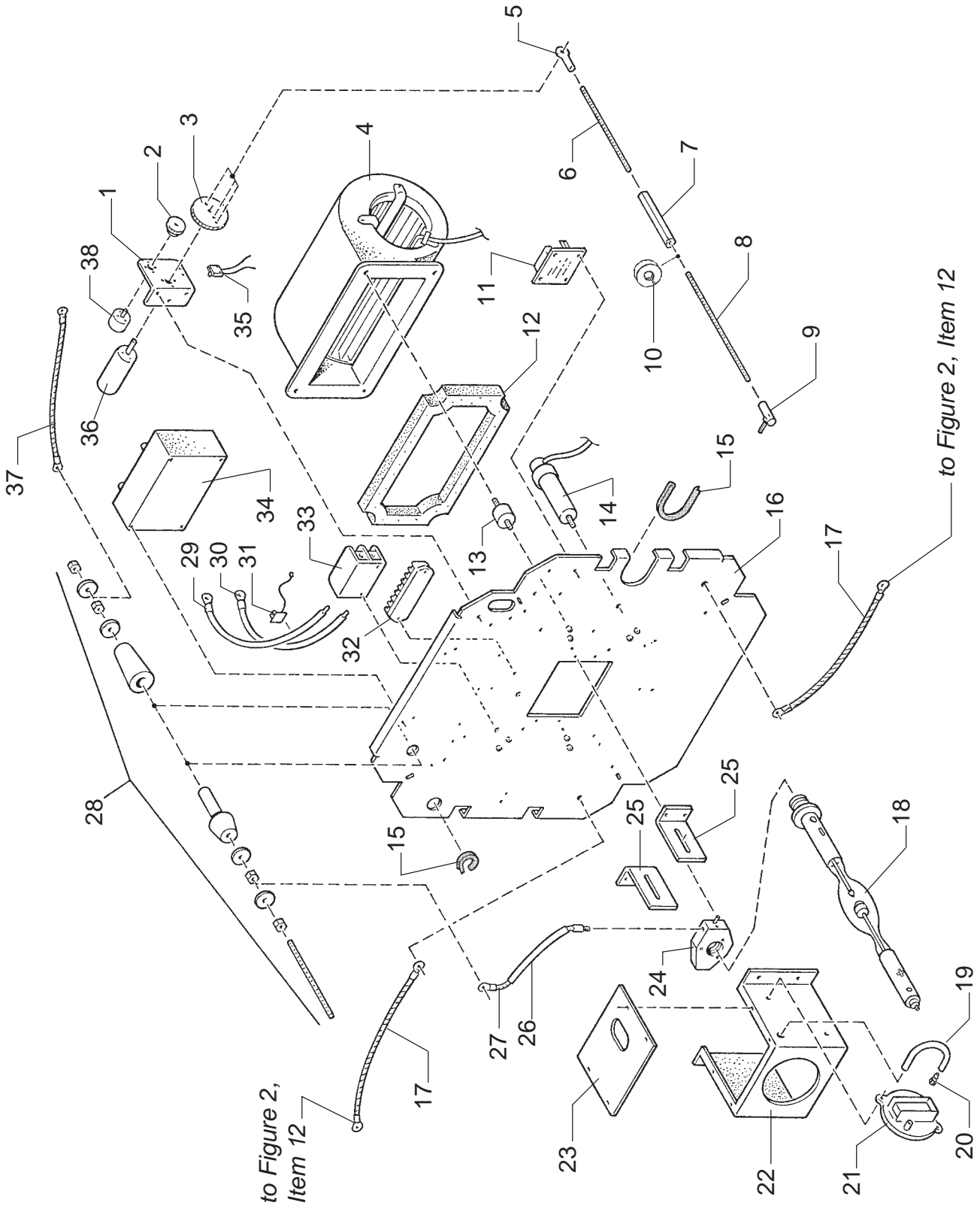

Lamphead Bulkhead Assembly

PARTS LIST

Figure 3

<u>Item</u>	<u>Part No.</u>	<u>Description</u>
1	32-40328	Mounting Bracket, Focus Motor
-	4100500	Bracket Mounting Screw, 10-32 x 1/2" Socket Head
-	4107001	Split Lockwasher, #10
2	31-23002	Encoder Gear
-	4060256	Set Screw, 6-32 x 1/4"
3	32-20143	Motor Gear
-	4060256	Set Screw, 6-32 x 1/4"
-	4080180	Screw, Limit Switch Actuator; 8-32 x 3/16" Socket Head
4	32-70225	Squirrelcage Blower Assembly, 230 V.AC, 50/60 Hz.
5	31-98133	Tie Rod End, Rear
-	4100621	Mounting Screw (to Item 3); 10-32 x 5/8" Pan Head
6	31-60089	Tie Rod, Rear
7	32-20322	Coupler, Tie Rods
8	31-60071	Tie Rod, Front
9	31-98131	Tie Rod End, Front
10	31-10022	Clamping Collar (2 req'd.)
11	32-70256	Printed Circuit Board, Motor Interface
12	31-22010	Blower Shock Mount Gasket
13	31-98182	Blower Shock Mount (4 req'd.)
14	31-08077	Motor Capacitor (for Item 4)
15	41-98127	Gasket Material, Insulated (order by foot)
16	32-40431	Bulkhead Plate
17	32-70255	Positive Lead Assembly
-	4371004	Screw, 3/8-16 x 1" Hex Head Brass
-	4378003	Hexnut, 3/8-16 Brass
-	4377002	Lockwasher, 3/8" Bronze
18	31-30243	Xenon Bulb, 7 kW Type XT
19	RU004000	Air Hose, Pressure Switch (order by foot)
20	31-20001	Hose Barb, Nylon (2 req'd.)
21	32-50345	Sensor Switch, Air Pressure
-	4080375	Mounting Screw, 8-32 x 3/8" Pan Head
22	32-50344	Plenum Bracket
-	4100500	Mounting Screw, 10-32 x 1/2" Socket Head
23	32-40294	Bracket Cover, Insulated
-	4080375	Mounting Screw, 8-32 x 3/8" Pan Head
24	32-50050	Receiver Block Assembly
-	41-51767	Shoulder Screw (not shown; 2 req'd.)
25	31-98076	Receiver Bracket, Insulated
26	81378000	Insulator Tube, Silastic Rubber
27	31-98078	Negative Lead Assembly, Receiver Block
28	31-98144	Feed-Through Connector Assembly
29	32-70206	Negative Lead Assembly
30	32-70205	Positive Lead Assembly

PARTS LIST, Figure 3 (continued)

<u>Item</u>	<u>Part No.</u>	<u>Description</u>
31	32-70140	Printed Circuit Board, Current Sensor
32	32-70213	Terminal Strip, AC
-	4080504	Mounting Screw, 8-32 x 1/2" Pan Head
33	31-34017	Terminal Strip, DC
-	410050B	Mounting Screw, 10-32 x 1/2" Pan Head
34	39862000	Igniter Assembly
-	4081251	Mounting Screw, 8-32 x 1-1/4" Socket Head
-	4087000	Split Lockwasher, #8
35	32-70248	Limit Switch, Focus Motor
-	4028001	Mounting Nut, 2-56 Hex
36	32-70249	Focus Motor, 24 V.DC, 187:1
-	4040182	Mounting Screw, 4-40 x 3/16" Flat Head
37	32-70254	Igniter Lead Assembly
38	32-70239	Encoder
-	4040182	Mounting Screw, 4-40 x 3/16" Flat Head
-	31-98748	Standoff, 4-40 x 1/4" (3 req'd.)
-	32-50351	Focus Motor & Encoder Assembly (Items 1-3 & 35-38 Complete)

FIGURE 4

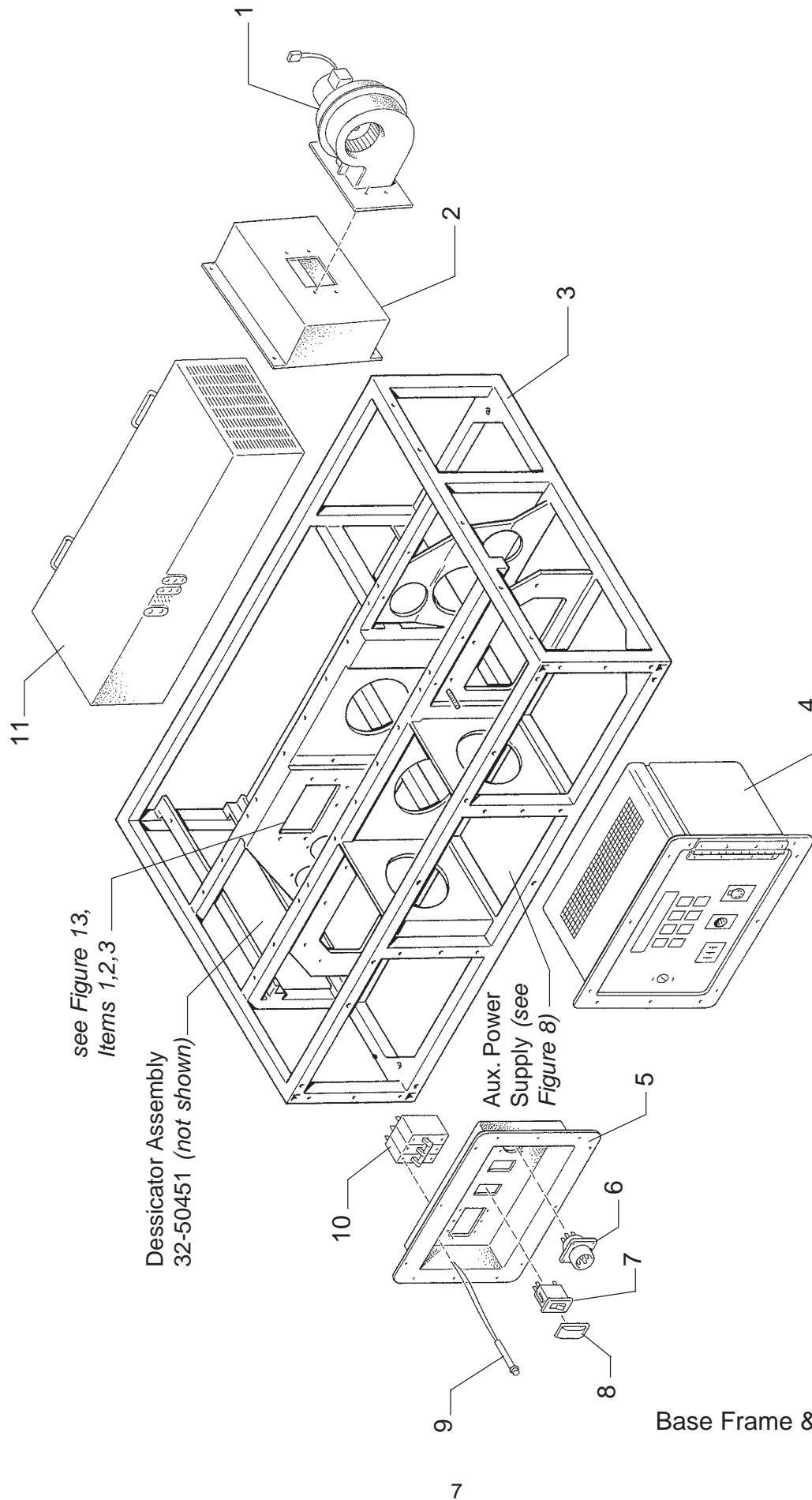

Base Frame & Components

PARTS LIST

Figure 4

<u>Item</u>	<u>Part No.</u>	<u>Description</u>
1	32-50333	Squirrelcage Blower Assembly, 230 V.AC, 50/60 Hz.
-	4080375	Mounting Screw, 3-82 x 3/8" Pan Head
2	31-98739	Plenum Bracket
-	4100250	Mounting Screw, 10-32 x 1/4" Pan Head
3	31-98851	Base Frame, Welded Assembly
4	32-50065	Motion Control Assembly (see Figure 7)
-	4080624	Cabinet Mounting Screw, 8-32 x 5/8" Pan Head
5	31-98850	Recessed Panel, AC Input
-	4080624	Mounting Screw, 8-32 x 5/8" Pan Head
6	31-13391	Plug, Chassis-Mount, (4) Pin
-	4088007	Mounting Nut, 8-32
7	3161015	Rocker Switch Circuit Breaker (2 req'd.)
8	31-61126	Cover, Circuit Breaker (2 req'd.)
9	31-30076	Indicator Light, Amber (4 req'd.)
9	31-30062	Indicator Light, Green (2 req'd.)
10	31-61109	Circuit Breaker, 3 Phase Switching
-	4060370	Mounting Screw, 6-32 x 3/8" Pan Head
-	32-70277	Power Inlet Assembly (Items 5-10)
11	62-86006	Xenon Power Supply Assembly (see Figure 13)
-	31-98735	Locking Bar, Power Supply (not shown)

FIGURE 5

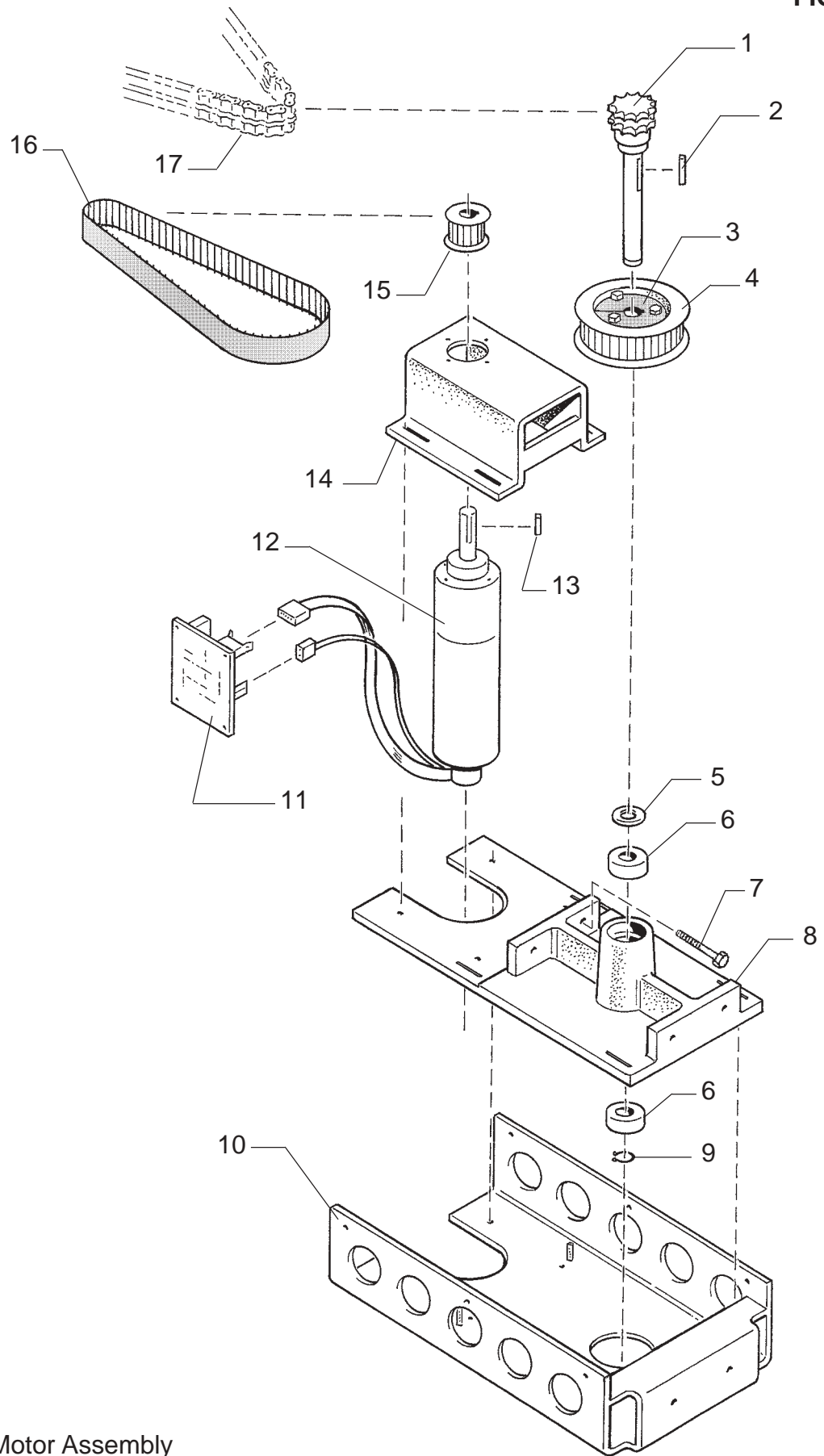

Pan Drive Motor Assembly

PARTS LIST

Figure 5

<u>Item</u>	<u>Part No.</u>	<u>Description</u>
1	31-59022	Sprocket & Shaft, Pan Drive
2	31-60042	Key, 3/16" Square
3	31-07014	Taper Lock Bushing
4	31-43013	Timing Belt Pulley
5	4757100	Thrust Washer
6	31-04020	Ball Bearing
7	4371750	Tensioning Screw, 3/8-16 x 1-3/4" Hex Head
-	4378001	Lock Nut, 3/8-16
8	31-39027	Bracket Casting, Pan Drive
-	4250755	Mounting Screw, 1/4-20 x 3/4" Socket Head
-	4257000	Lockwasher, 1/4"
9	31-48003	Snap Ring
10	32-40330	Casting Mounting Pan
-	4250503	Mounting Screw, 1/4-20 x 1/2" Hex Head
-	4257000	Lockwasher, 1/4"
11	31-72042	Printed Circuit Board, Motor Interface
12	31-33016	Servo Motor Assembly, 48 V.DC
-	410050B	Mounting Screw, 10-32 x 1/2" Pan Head
13	31-60042	Key, 3/16" Square
14	32-40331	Servo Motor Bracket
-	4250503	Mounting Screw, 1/4-20 x 1/2" Hex Head
-	4257000	Lockwasher, 1/4"
-	4257104	Flatwasher, 1/4"
15	31-43013	Timing Belt Pulley
-	4100252	Set Screw, 10-32 x 1/4"
16	31-05015	Timing Belt, 68 Tooth
17	32-00330	Roller Chain, 73"
-	31-98248	Master Link, Roller Chain (incl. with Item 17)

FIGURE 6

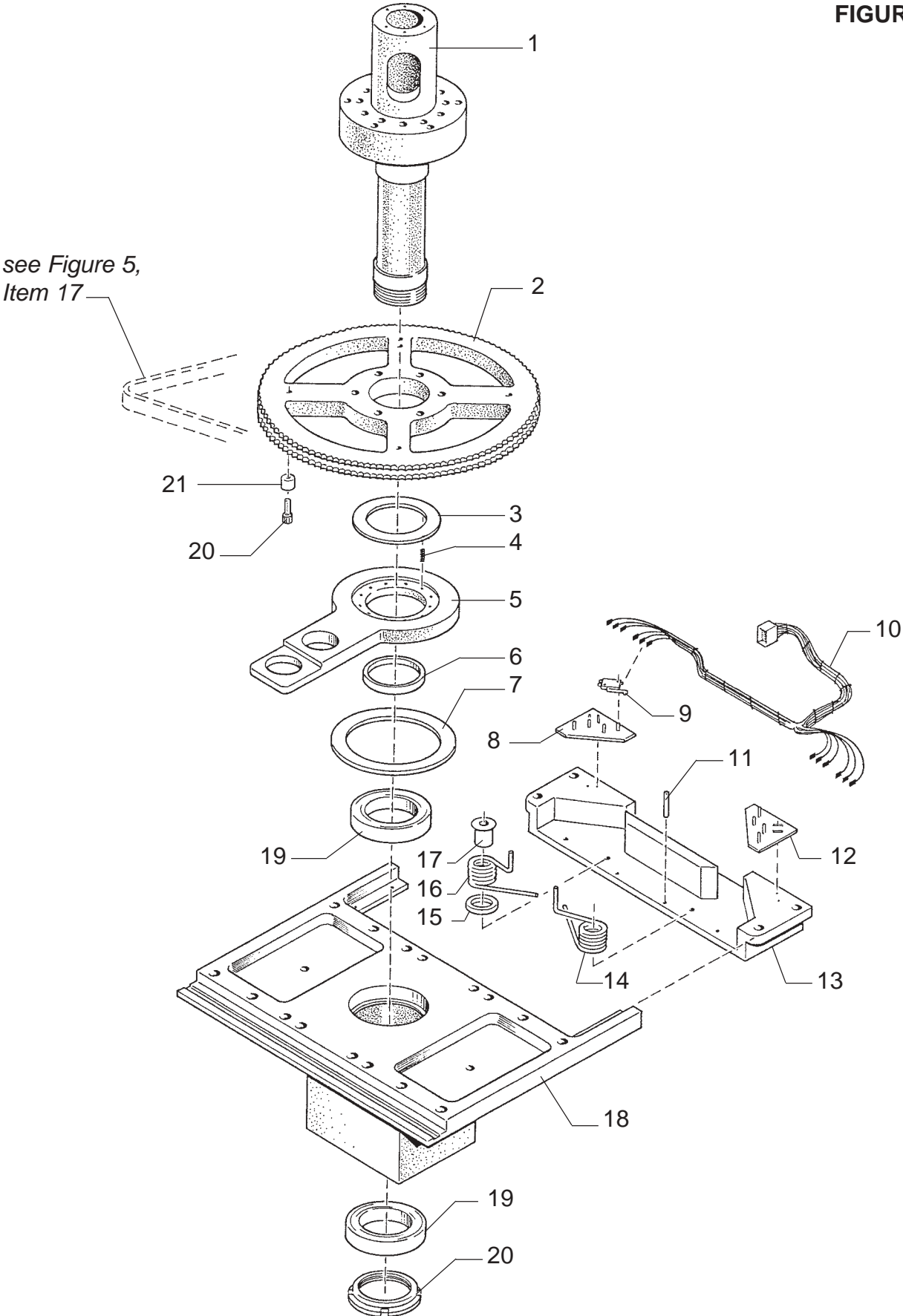

Pan Drive Assembly

PARTS LIST

Figure 6

<u>Item</u>	<u>Part No.</u>	<u>Description</u>
1	32-00290	Pan Axle
2	31-59021	Driven Sprocket
-	4502001	Mounting Screw (to Item 1), 1/2-13 x 2" Hex Head
3	32-00157	Thrust Washer, Small
4	31-58029	Compression Spring (12 req'd.)
5	31-98846	Pan Limit Arm Casting
6	31-56032	Spacer
7	32-00158	Thrust Washer, Large
8	32-40342	Limit Switch Plate, Left
9	31-61005	Limit Switch (4 req'd.)
10	---	Wire Harness
-	81-71043	Wire, AWG 20, Yellow (10 ft.)
-	81-71061	Wire, AWG 20, Grey (10 ft.)
-	81-71081	Wire, AWG 20, Green (10 ft.)
11	31-37007	Pin, 1/4 x 1-1/4"
12	32-40343	Limit Switch Plate, Right
13	31-39089	Base, Pan Limit Switch Assembly
-	4250755	Mounting Screw, 1/4-20 x 3/4" Socket Head
14	31-58036	Torsion Spring, Right
15	32-00284	Spacer, Phenolic (2 req'd.)
16	31-58034	Torsion Spring, Left
17	32-20138	Spring Arbor Bushing (2 req'd.)
-	4371503	Bushing Screw (not shown), 3/8-16 x 1-1/2" Socket Head
18	31-29076	Pan Drive Housing
19	31-04016	Ball Bearing
20	4370752	Screw, 3/8-16 x 3/4" Socket Head
21	32-00283	Pan Stop Bushing

FIGURE 7

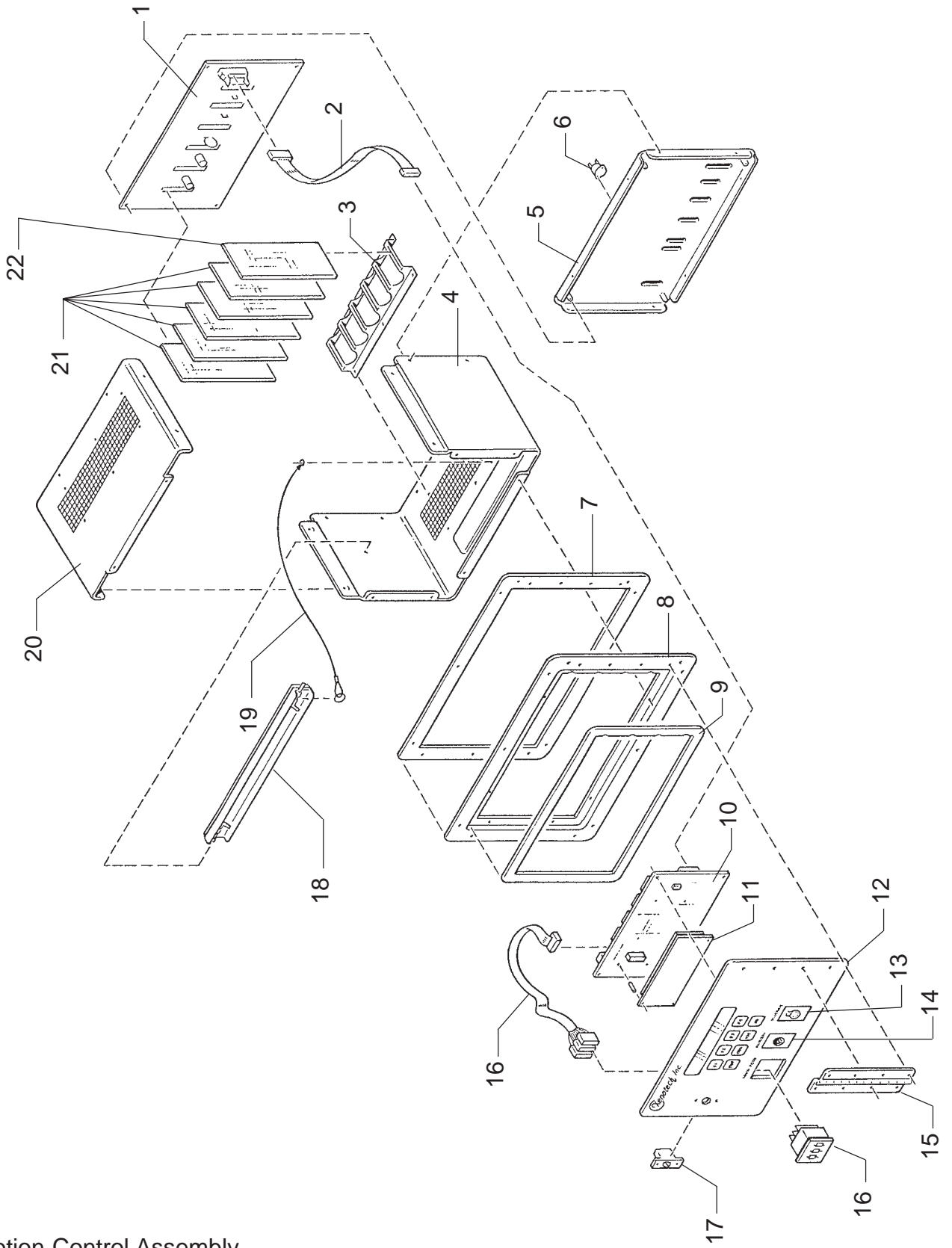

Motion Control Assembly

PARTS LIST

Figure 7

<u>Item</u>	<u>Part No.</u>	<u>Description</u>
1	32-70075	Motherboard Assembly
-	4080181	Mounting Screw, 8-32 x 3/16" Pan Head
2	32-70076	Ribbon Cable Assembly
3	32-40415	PC Board Guide Bracket (2 req'd.)
-	4060375	Mounting Screw, 6-32 x 3/8" Flat Head
4	32-40461	Cabinet Base
5	32-40195	Cabinet Back
-	4060375	Mounting Screw, 6-32 x 3/8" Flat Head
6	31-61007	Thermal Switch, open at 220° F.
-	4048007	Mounting Nut, 4-40 Hex
7	31-22002	Gasket, Self-Adhesive
8	32-00278	Flange
-	4060375	Mounting Screw, 6-32 x 3/8" Flat Head
9	31-22003	Gasket, Self-Adhesive
10	32-70074	Printed Circuit Board Assembly (with Item 11)
-	32-98403	Battery, 3 V. 1/2 A.
-	4080181	Mounting Screw, 8-32 x 3/16" Pan Head
11	32-70139	LCD Screen (incl. with Item 10)
12	32-40194	Front Panel
-	31-61130	Membrane Overlay
13	32-70077	DMX Connector, (5) Pin Female
14	32-70078	DMX Connector, (5) Pin Male
15	32-40346	Hinge
-	4060375	Mounting Screw, 6-32 x 3/8" Flat Head
16	32-70296	DMX Address Display & Cable Assembly
17	31-28019	Latch
18	32-40410	Retaining Bar, PC Boards
19	31-98178	Lanyard, 3/64" x 12"
-	31-48002	Ring (to Item 18)
-	85201A00	Ring Terminal (to Item 4)
-	4088007	Hexnut, 8-32, Self-Lock (to Item 4)
-	32-50057	Retainer Assembly (Items 17 & 18, Complete)
20	32-40422	Top Cover
-	4060375	Mounting Screw, 6-32 x 3/8" Flat Head
21	32-70229	Printed Circuit Board Assembly, "MOT-3"
22	32-70073	Printed Circuit Board Assembly, "Supervisory"
		NOT SHOWN (mounted below Item 4)
-	32-70266	Blower Assembly, 24 V.DC
-	32-70259	Heater Element, 150 Watt, 230 V.AC (ref. Figure 8, Item 4)

FIGURE 8

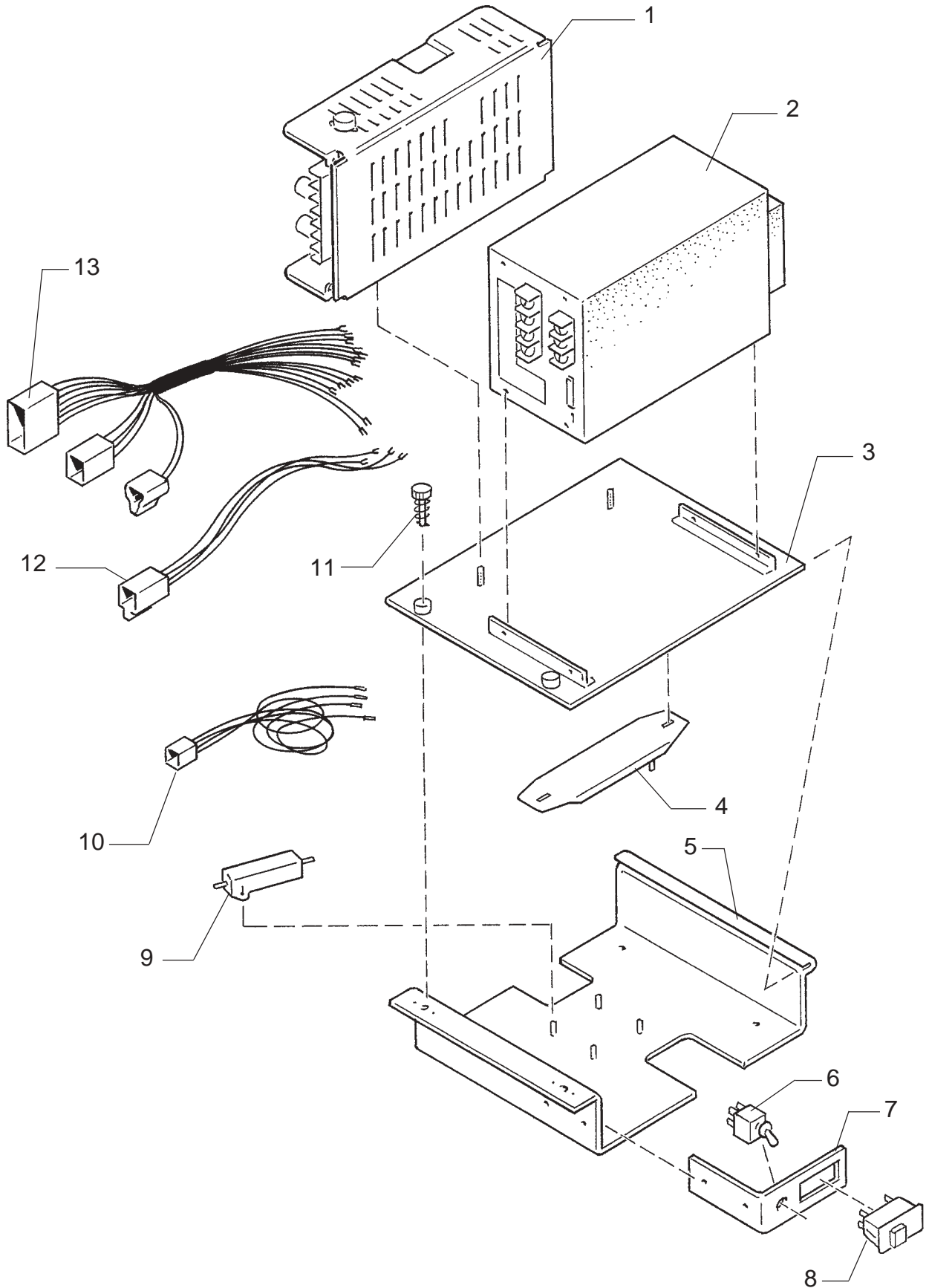

Auxiliary Power Supply Assembly

PARTS LIST

Figure 8

Item	Part No.	Description
1	31-98380	Power Supply Assembly; 150 Watt, 24 Volt
-	4088001	Mounting Nut, 8-32 Hex
2	31-98381	Power Supply Assembly, 500 Watt, 48 Volt
-	4060250	Mounting Screw, 6-32 x 1/4" Pan Head
3	32-40059	Mounting Plate Assembly
4	32-70259	Heater Element, 150 Watt, 230 V.AC
-	4100371	Mounting Screw, 10-32 x 3/8" Pan Head
5	32-40344	Base Bracket
6	31-61048	Toggle Switch, Heater
7	32-40429	Bracket
8	31-61015	Circuit Breaker, Heater; 5 A.
9	31-46060	Bleeder Resistor, 100 Ohm, 50 W. (2 req'd.)
-	4048001	Hexnut, 4-40
10	32-70261	Wire Harness Assembly (incl. 2 ea. Item 9)
11	31-98209	Captive Fastener, Quarter-Turn
12	32-70260	Wire Harness Assembly
13	32-70262	Wire Harness Assembly

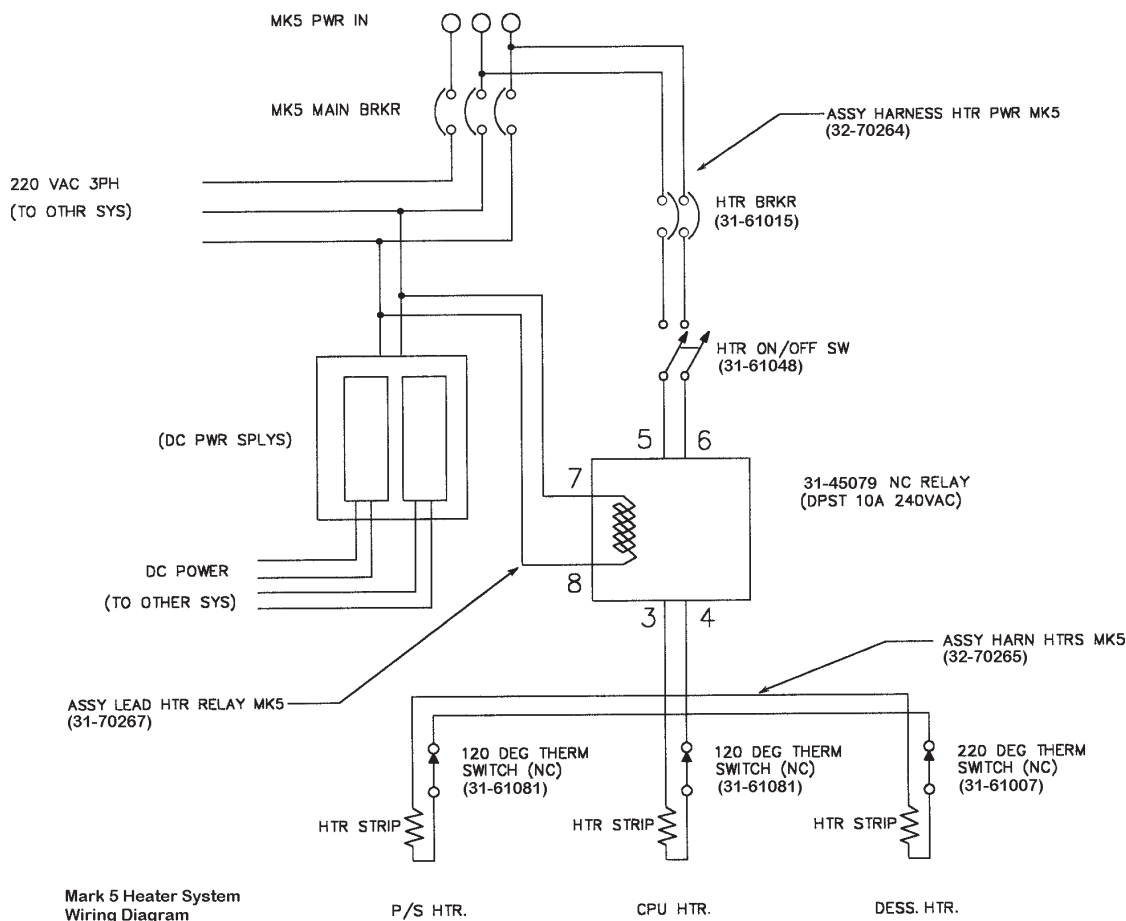
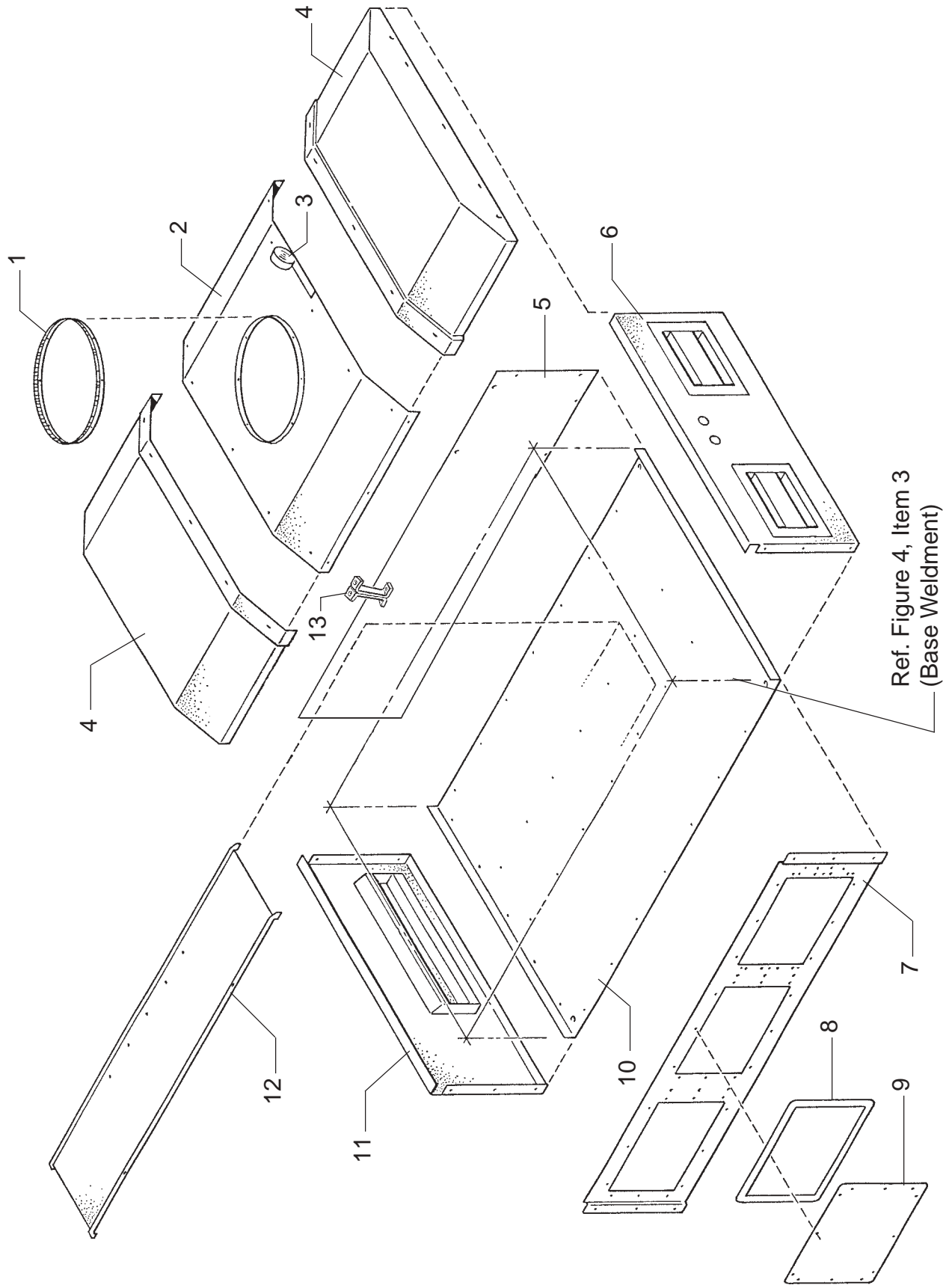

FIGURE 9



Base Frame Housing

PARTS LIST

Figure 9

<u>Item</u>	<u>Part No.</u>	<u>Description</u>
1	31-98867	Ring, WeatherSeal
-	4060370	Mounting Screw, 6-32 x 3/8" Pan Head
2	31-29179	Cover Panel, Top Center
-	4250753	Mounting Screw, 1/4-20 x 3/4" Pan Head
-	4257106	Washer, 1/4" WeatherSeal
3	31-98153	Weatherstripping Tape (order by foot)
4	31-29180	Top Cover Panel, Left & Right
-	4250753	Mounting Screw, 1/4-20 x 3/4" Pan Head
-	4257106	Washer, 1/4" WeatherSeal
5	31-29182	Cover Plate
-	410050B	Mounting Screw, 10-32 x 1/2" Pan Head
6	31-29144	End Cover, Welded Assembly
-	410050B	Mounting Screw, 10-32 x 1/2" Pan Head
7	31-29142	Cover Panel, Control Side
-	410050B	Mounting Screw, 10-32 x 1/2" Pan Head
8	31-22002	Gasket
9	31-18029	Cover Plate, Auxiliary Power Supply Compartment
-	4080624	Mounting Screw, 8-32 x 5/8" Pan Head
10	31-29027	Bottom Cover Plate
-	4250750	Mounting Screw, 1/4-20 x 3/4" Flat Socket Head
11	31-29145	End Cover, Welded Assembly
-	410050B	Mounting Screw, 10-32 x 1/2" Pan Head
12	31-98885	Inner Drip Shield
-	4100371	Mounting Screw, 10-32 x 3/8" Pan Head
13	31-06094	Top Cover Brace (4 req'd.)
-	4250623	Mounting Screw, 1/4-20 x 5/8" Hex Head
-	4257000	Split Lockwasher, 1/4"

FIGURE 10

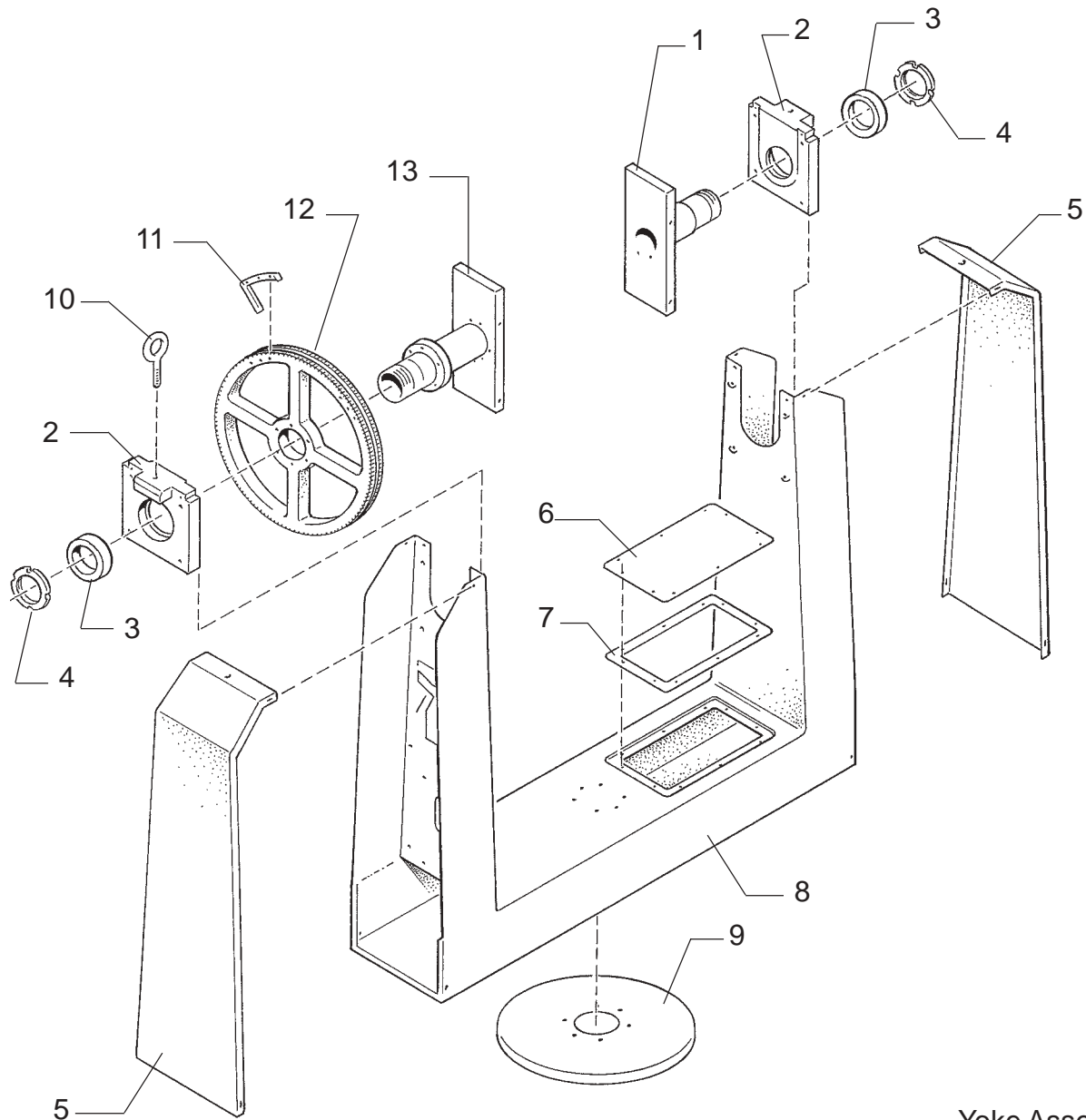

Yoke Assembly

<u>Item</u>	<u>Part No.</u>	<u>Description</u>
1	31-98729*	Tilt Axle, Non-Driven
-	4251120	Mounting Screw, 1/4-20 x 1-1/8" Hex Head
-	4257000	Split Lockwasher, 1/4"
-	4257102	Flatwasher, 1/4" SAE
2	31-29181	Bearing Block
-	4371002	Mounting Screw, 3/8-16 x 1" Socket Head
-	4377001	Split Lockwasher, 3/8"
-	4377103	Flatwasher, 3/8" SAE
3	31-04015	Ball Bearing
4	31-04033	Bearing Nut

* Items 1 & 13 mount to Lamphed Frame (Figure 2, Item 4)

PARTS LIST, Figure 10 (continued)

<u>Item</u>	<u>Part No.</u>	<u>Description</u>
5	31-98864	Yoke Side Cover
-	4080506	Mounting Screw, 8-32 x 1/2" Pan Head
6	32-40348	Cover Plate, Wire Access
-	4080503	Mounting Screw, 8-32 x 1/2" Flat Head
7	31-22008	Gasket
8	31-98863	Yoke, Welded Assembly
9	31-98820	Cover, Pan Axle
10	31-51060	Eyebolt (2 req'd.)
-	4508001	Hexnut, 1/2-13 (not shown)
11	31-59024	Switch Actuator (2 req'd.)
-	4251002	Mounting Screw, 1/4-20 x 1" Socket Head
12	31-59023	Sprocket
-	4251002	Mounting Screw, 1/4-20 x 1" Socket Head
13	31-98727*	Tilt Axle, Driven
-	4251120	Mounting Screw, 1/4-20 x 1-1/8" Hex Head
-	4257000	Split Lockwasher, 1/4"
-	4257102	Flatwasher, 1/4" SAE

* Items 1 & 13 mount to Lamphed Frame (Figure 2, Item 4)

Tilt Drive Assembly

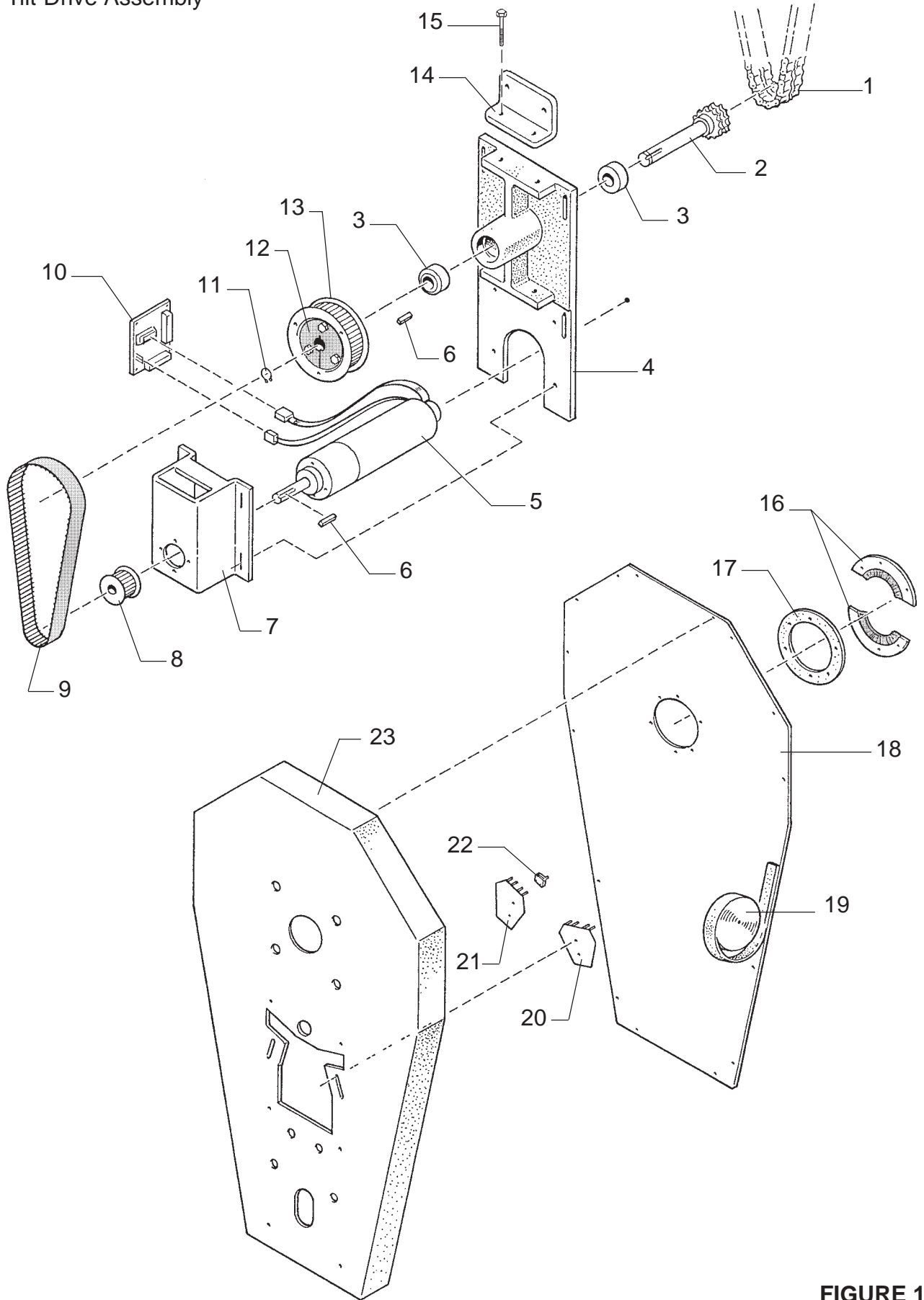

FIGURE 11

PARTS LIST

Figure 11

<u>Item</u>	<u>Part No.</u>	<u>Description</u>
1	32-00331	Roller Chain, 76"
-	31-98248	Master Link, Roller Chain (incl. with Item 1)
2	31-59018	Sprocket & Shaft
3	31-04020	Ball Bearing
4	31-39087	Bracket Casting
-	4250505	Mounting Screw, 1/4-20 x 1/2" Socket Head
-	4257104	Flatwasher, 1/4"
5	31-33016	Servo Motor, 12 V.DC
-	41-51254	Mounting Screw, Metric
6	31-60042	Key, 3/16" Square
7	31-40331	Motor Mounting Bracket
-	4250503	Mounting Screw, 1/4-20 x 1/2" Hex Head
-	4257000	Split Lockwasher, 1/4"
-	4257102	Flatwasher, 1/4" SAE
8	31-43019	Timing Belt Pulley
9	31-05015	Timing Belt, 68 Tooth
10	32-70141	Printed Circuit Board, Motor Interface
-	4060250	Mounting Screw, 6-32 x 1/4" Pan Head
11	31-48003	Snap Ring
12	31-07014	Taper Lock Bushing
13	31-43013	Timing Belt Pulley
14	31-06058	Tensioning Bracket
-	4370750	Mounting Screw, 3/8-16 x 3/4" Hex Head
-	4377001	Split Lockwasher, 3/8"
-	4377102	Flatwasher, 3/8"
15	4371503	Tensioning Screw, 3/8-16 x 1-1/2" Socket Head
16	31-98866	WeatherSeal
-	4080375	Mounting Screw, 8-32 x 3/8" Pan Head
17	31-22007	Gasket
18	31-29184	Cover Plate, Chain Guard
-	4100371	Mounting Screw, 10-32 x 3/8" Pan Head
19	31-98153	Weatherstripping Tape (order by foot)
20	32-40423	Limit Switch Bracket, Right
21	32-40421	Limit Switch Bracket, Left
-	4100620	Bracket Mounting Screw, 10-32 x 5/8" Socket Head
-	4107000	Split Lockwasher, #10
-	4107104	Flatwasher, #10
22	31-61005	Limit Switch
-	4048001	Switch Mounting Nut, 4-40 Hex
23	31-98852	Chain Guard
-	4080250	Mounting Screw, 8-32 x 1/4" Pan Head

FIGURE 12

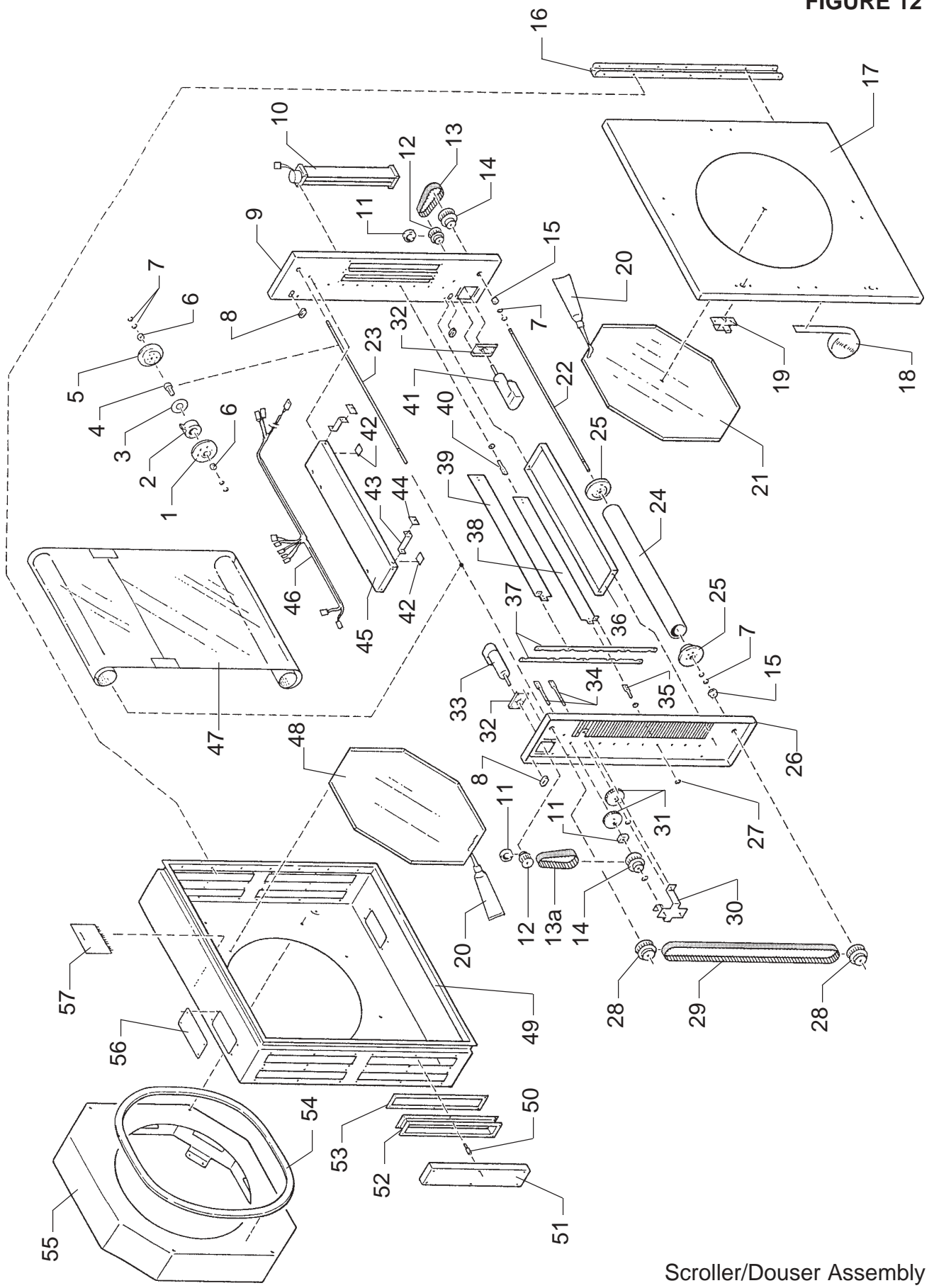

Scroller/Douser Assembly

PARTS LIST

Figure 12

<u>Item</u>	<u>Part No.</u>	<u>Description</u>
1	31-04038	Flange, Driven (Racheting) Scroller Spool
2	31-58022	Coil Spring, Spool Ratchet
3	4627101	Washer, 5/8"
4	31-01004	Ratchet Pawl
5	31-04038	Flange, Driven Spool
-	32-20132	Scroller Spool (ref. Item 24)
6	31-04013	Ball Bearing
7	31-98075	Snap Ring, 1/4"
8	51-98026	Grommet, Black Rubber
9	31-98660	End Panel, Scroller Drive
10	32-70157	Blower, 24 V.DC (2 req'd.)
-	4060250	Mounting Screw, 6-32 x 1/4" Pan Head
11	31-10023	Hub Clamp
12	32-20128	Timing Belt Pulley
13	31-05006	Timing Belt, 45 Tooth
13a	31-05004	Timing Belt, 35 Tooth
14	31-23023	Timing Belt Pulley
15	31-04022	Ball Bearing
16	31-18014	Hinge
17	32-00293	Cover
18	31-22004	Weatherstripping Tape, Self-Adhesive (order by foot)
19	31-28013	Latch
20	11-98069	Silicone Sealant, RTV 736 (3 oz. Tube)
21	31-98291	Cover Glass, Tempered
22	32-20118	Shaft, Drive Spool
23	32-20115	Shaft, Driven Spool
24	32-20132	Scroller Spool (2 req'd.)
-	4040374	Fastening Screw, 4-40 x 3/8" Flat Head
25	32-00296	Flange, Driven Spool
-	4100379	Set Screw, 10-32 x 3/8"
26	32-40327	End Panel, Douser Drive
27	31-98075	Snap Ring, 1/4"
28	32-20131	Timing Belt Pulley
29	31-05003	Timing Belt, 284 Tooth, Metric
30	32-00295	Bracket, Douser Blade Shafts
31	31-23023	Douser Blade Drive Gear
32	32-40318	Motor Mounting Plate (incl. with Items 33 & 41)
33	32-70202	Douser Blade Drive Motor Assembly, 24 V.DC, 19:1
34	32-20105	Douser Blade Drive Shaft, Long (2 req'd.)
-	4060180	Mounting Screw, 6-32 x 3/16" Pan Head
35	32-20106	Douser Blade Drive Shaft, Short (16 req'd.)
-	4060180	Mounting Screw, 6-32 x 3/16" Pan Head

PARTS LIST, Figure 12 (continued)

<u>Item</u>	<u>Part No.</u>	<u>Description</u>
36	31-98658	End Bracket
-	4100371	Mounting Screw, 10-32 x 3/8" Pan Head
37	32-50437	Torque Transfer Arm
38	32-40341	Douser Blade, Odd (5 req'd.)
-	32-00335	Pivot Shaft (see Item 40)
39	32-40340	Douser Blade, Even (5 req'd.)
40	32-00335	Douser Blade Pivot Shaft (10 req'd.)
-	4060180	Mounting Screw, 6-32 x 3/16" Pan Head
41	32-70268	Scroller Drive Motor Assembly, 24 V.DC, 5.2:1
42	32-70245	PC Board, Gel Detector Opto Sensor (with Item 44)
43	31-06055	Mounting Bracket, PC Board (2 req'd.)
-	4060250	Mounting Screw, 6-32 x 1/4" Pan Head
44	32-70245	PC Board, Gel Detector Opto Sensor (with Item 42)
45	31-98658	End Bracket
-	4100371	Mounting Screw, 10-32 x 3/8" Pan Head
46	---	Wire Harness (see ASSEMBLIES below)
47	---	Color Scroll (by Customer)
48	31-98305	Hot Mirror, Tempered
49	31-29117	Housing, Welded Assembly
50	41-98090	Spacer, 3/8" Threaded 8-32 (48 req'd.)
51	32-40401	Cover, Intake
52	31-98871	Intake Channel
53	31-22009	Gasket
54	31-98874	Weather Seal (order by foot)
55	32-50460*	Cowl, Welded Assembly
-	31-98209	Captive Fastener, Quarter-Turn (8 req'd.)
56	32-00294	Cover, Access
-	31-98686	Gasket (not shown)
57	32-70253	PC Board, DMX Interface
-	32-70275	Cable Assembly to Lamphead (Figure 2, Item 7)

* Not included with 32-50461; order separately

ASSEMBLIES

32-50438	Scroller Spool & Shaft, Driven (Items 1-7 , 23 & 24)
32-50439	Scroller Spool & Shaft, Drive (Items 7, 22, 24, 25)
32-70250	Wire Harness, Douser
32-70251	Wire Harness, Scroller Fan
32-70252	Wire Harness, Opto Sensors
32-70447	Wire Harness, Scroller

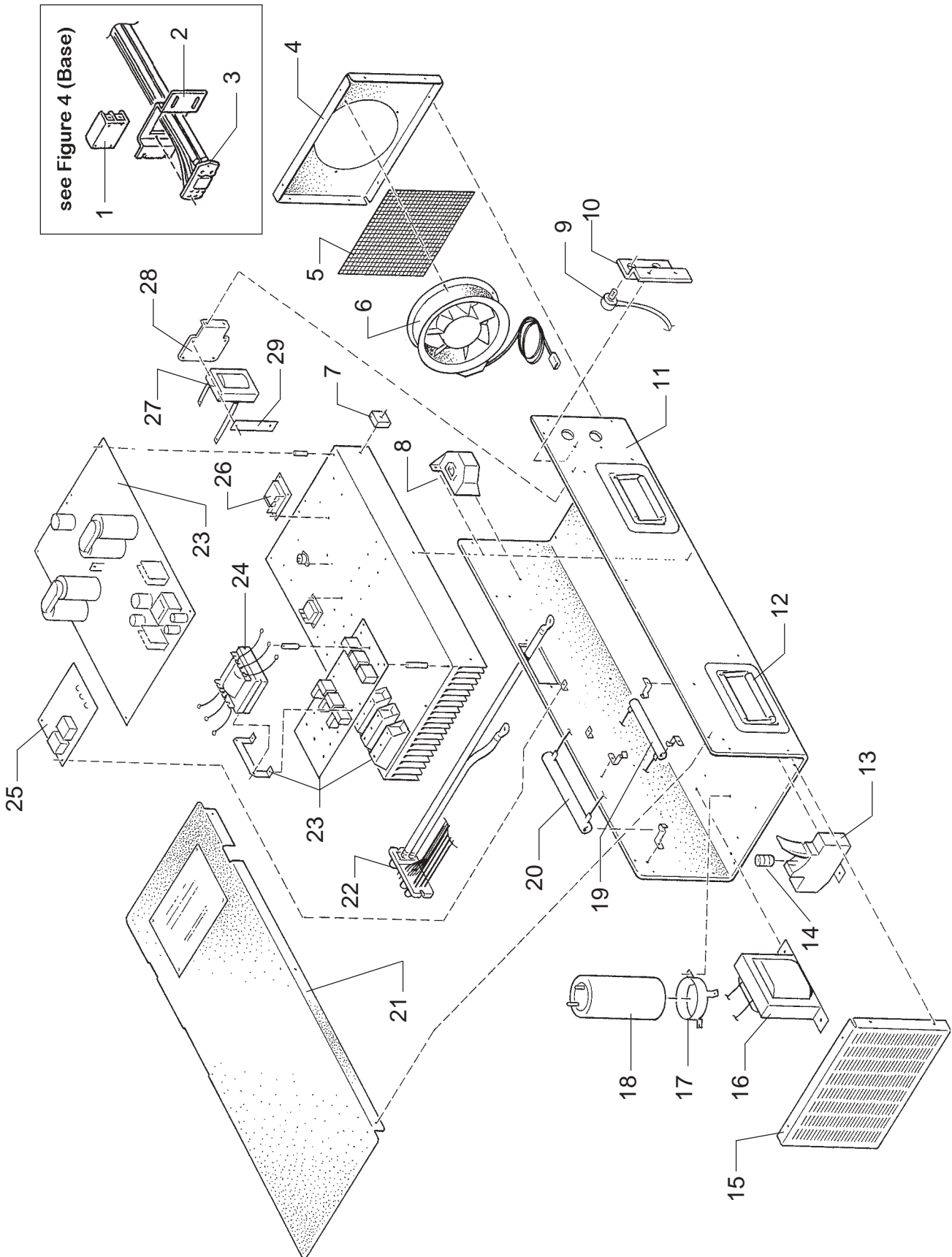

FIGURE 13

PARTS LIST

Figure 13

<u>Item</u>	<u>Part No.</u>	<u>Description</u>
1	31-62025	Barrier Strip, (2) Terminal
-	410050B	Mounting Screw, 10-32 x 1/2" Pan Head
2	31-06061	Receptacle Mounting Bracket
-	4250503	Mounting Screw, 1/4-20 x 1/2" Hex Head
-	4257000	Split Lockwasher, 1/4"
-	4257102	Flatwasher, 1/4"
3	31-13063	Power Supply Receptacle, Molded
-	31-13064	DC Socket, Brass (2 req'd.)
-	32-70289	Wire Harness, Power Supply Control
-	31-51001	Receptacle Mounting Screw
4	62-84010	Blower Panel
-	4080313	Mounting Screw, 8-32 x 5/16" Flat Head
5	62-40048	Blower Grille
6	61-98020	Blower, 230 V.AC, 50/60 Hz.
-	4060500	Mounting Screw, 6-32 x 1/2" Pan Head
-	4068001	Hexnut, 6-32
7	61-98021	Spacer (6 req'd.)
8	31-72056	LEM Module
-	4080503	Mounting Screw, 8-32 x 1/2" Flat Head
-	4088001	Hexnut, 8-32
9	61-69004	Potentiometer, 5k Ohm, Current Control (2 req'd.)
10	62-40023	Potentiometer Mounting Bracket
-	4080313	Mounting Screw, 8-32 x 5/16" Flat Head
11	62-40086	Cabinet Base
12	77271000	Folding Handle (2 req'd.)
13	61-21004	Fuse Holder
-	4080313	Mounting Screw, 8-32 x 5/16" Flat Head
14	61-21006	Fuse, 440 V, 40 Amp.
15	62-40085	End Panel
-	4080313	Mounting Screw, 8-32 x 5/16" Flat Head
16	61-64010	Inductor
-	4080622	Mounting Screw, 8-32 x 5/8" Flat Head
17	61-06001	Capacitor Clamp (2 req'd.)
-	4080313	Mounting Screw, 8-32 x 5/16" Flat Head
-	4088001	Hexnut, 8-32
18	61-08025	Capacitor (2 req'd.)
19	61-46067	Resistor
-	31-06001	Mounting Clip (2 req'd.)
-	4080313	Clip Mounting Screw, 8-32 x 5/16" Flat Head
-	4088001	Hexnut, 8-32

PARTS LIST, Figure 13 (continued)

<u>Item</u>	<u>Part No.</u>	<u>Description</u>
20	61-46066	Resistor
-	21-06038	Mounting Clip (2 req'd.)
-	4080313	Clip Mounting Screw, 8-32 x 5/16" Flat Head
-	4088001	Hexnut, 8-32
21	62-40084	Top Cover
-	4080313	Mounting Screw, 8-32 x 5/16" Flat Head
22	32-70024	Power Supply Interface Jack, Wired Assembly
-	31-51001	Shoulder Screw
23	62-80067	Main Power Module (sold as <i>Assembly only</i>)
24	61-64016	Transformer, RFI Input
-	4060370	Mounting Screw, 6-32 x 3/8" Pan Head
-	4068001	Hexnut, 6-32
25	61-17009	Switching Diode
26	32-70154	PC Board, Ballast Sense
-	31-06001	Mounting Bracket (2 req'd.)
-	4063000	Mounting Screw, 6-32 x 3" Pan Head (1 req'd.)
-	4060370	Mounting Screw, 6-32 x 3/8" Pan Head (2 req'd.)
-	4068001	Hexnut, 6-32 (2 req'd.)
27	62-40077	Choke
28	62-40050	Choke Mounting Bracket
-	4100623	Mounting Screw, 10-32 x 5/8" Flat Head
-	4108001	Hexnut, 10-32
29	62-40052	Retaining Bar (2 req'd.)
-	4082750	Mounting Screw, 8-32 x 2-3/4" Pan Head
-	4088001	Hexnut, 8-32

WARRANTY STATEMENT

Strong Entertainment Lighting agrees that its products shall be free from defects in materials and workmanship over a period of one year from the date of shipment from its factory. This warranty is nontransferable and applies to the original purchaser only. Said warranty will not apply if equipment is used in condition of service for which it is not specifically intended. The manufacturer is not responsible for damage to its apparatus through improper installation, physical damage or poor operating practice.

If any device is found to be defective under the warranty, the buyer should notify the manufacturer in writing. Such equipment will be repaired or replaced, at manufacturer's option, free of all charges except transportation, F.O.B. its factory, such repair or replacement by the manufacturer shall constitute fulfillment of all obligations to the purchaser. This warranty does not include troubleshooting expense, labor charges associated with service calls, disassembly or reassembly of the lamp system. Should such repair or replacement require an on-site service call, the Purchaser shall bear the responsibility for all costs and associated expenses. Manufacturer does not assume responsibility for unauthorized repairs to its products, even though defective, and any unauthorized parts or repairs shall void this warranty.

This warranty is the only warranty given with respect to manufacturer's products, and there are no warranties of merchantability or fitness for a particular purpose or other warranties or representations of any kind, express or implied, which are made with respect to these products.

The remedies of the Owner set forth in this warranty are exclusive. In no event shall the buyer be entitled to recover for incidental, special or consequential damages, arising from the sale or use of these products, including but not limited to loss of profits or revenue, other commercial losses, inconvenience, delay, labor, repairs or other cost of rental or replacement equipment.

This warranty excludes any and all incidental damage that may be caused by lamp explosions. The lamps used in manufacturer's products are not included in this warranty, however are covered in lamp manufacturer's warranty.

