



FOLLOW SPOTLIGHT INSTRUCTION MANUAL

Equipment Type 7201111 • Rev. July 2006



a division of Ballantyne of Omaha, Inc.

4350 McKinley Street • Omaha, Nebraska 68112 USA
Tel (402) 453-4444 • Fax (402) 453-7238 • www.strong-lighting.com

PREFACE

THE STRONG RADIANCE SPOTLIGHT is an AC follow spot complete with lamphouse, igniter, power supply, optical system, and color boomerang. The light source is a 850 watt DC double-ended EmArc® metal halide lamp. Lamps are not supplied with the unit, but are readily available from theatrical supply distributors.

AN ELLIPTICAL REFLECTOR is designed to operate in a fixed position with the lamp mounted horizontally in the lamphouse. The lamp socket is adjustable in relation to the optics to permit positioning the arc to the optical center line of the reflector. The igniter is contained within the lamphouse enclosure.

THE POWER SUPPLY mounts below the lamphouse and comes equipped with a three-wire AC line cord that connects to a 115 volt, single phase 60 Hertz AC line. A 230 volt, 50 Hertz export model is also available. The power supply is protected by a 15 ampere fuse, and operation of the power supply is controlled by the ON/OFF toggle switch on the lamphouse. An elapsed hour meter records lamp usage.

ADJUSTMENT CONTROLS for positioning the metal halide lamp are located below a cover at the rear of the lamphouse. This control mechanism permits concise positioning of the lamp in relation to the reflector and also allows the lamp to be centered both vertically and horizontally on the optical center of the reflector.

AN INTERNALLY WIRED FAN is used in the followspot lamphouse and operates from the AC control circuit. This blower is wired through a time delay relay to permit the lamp to reach full intensity more quickly. A thermal switch will interrupt operation of the spotlight if the fan fails to move enough air to adequately cool the lamphouse.

NOTICE

The metal halide lamp contains **mercury** and expired lamps should not be discarded in an ordinary refuse container. Conform to local Hazardous Materials ordinances or refer to www.lamprecycle.org.

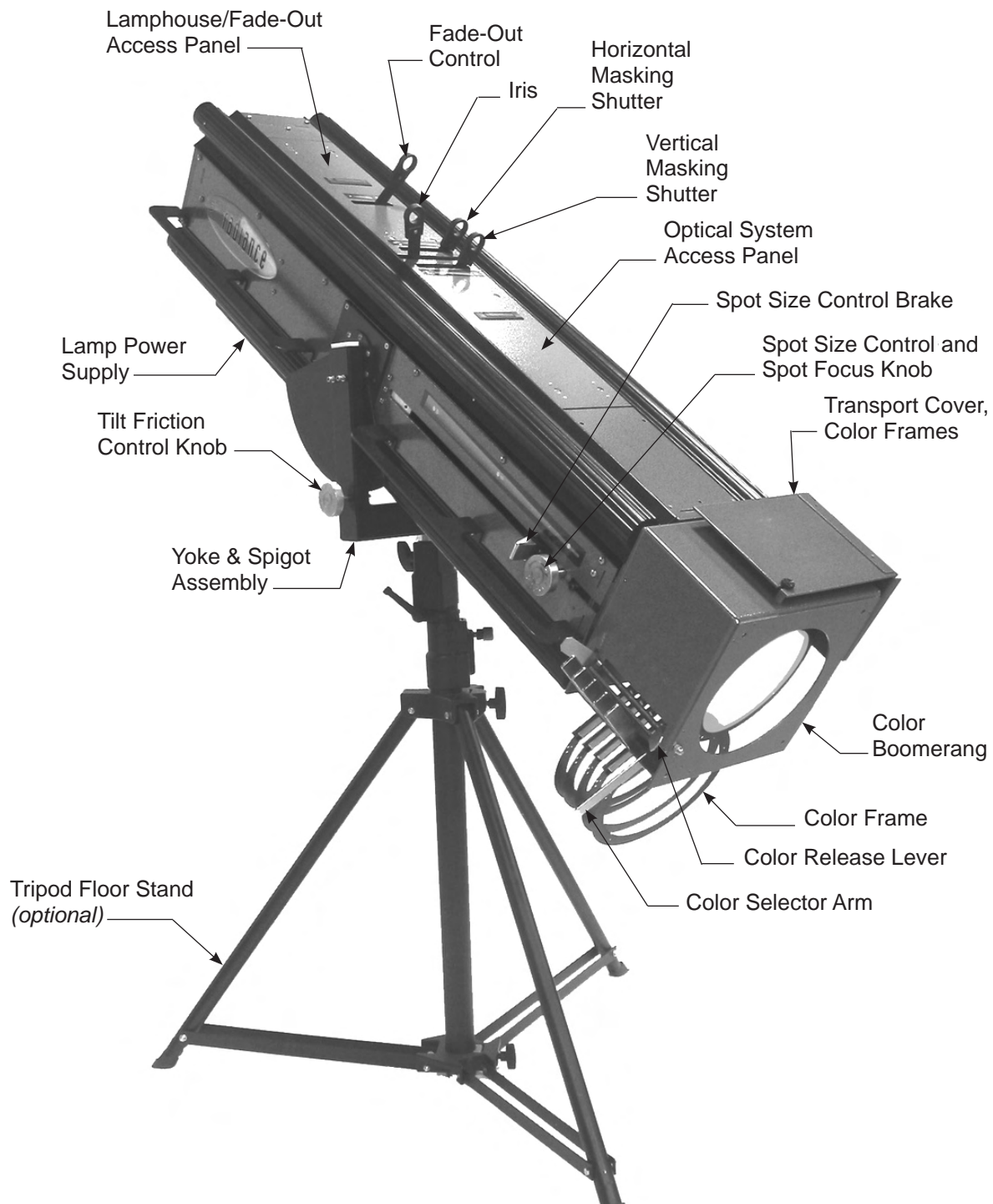

SETTING UP FOLLOW SPOT

THE RADIANCE FOLLOW SPOT is shipped in sections which must be assembled. The yoke and spigot (truss pin) are included with the head assembly; the tripod floor stand is a factory-supplied option.

THE SPIGOT is a standard 28mm (1-1/8 inch) diameter for truss mounting. The spigot will also seat into the top of the optional tripod base stand. Height of the unit may be determined by the user, but when adjusting the tripod base, make certain the unit remains stable. Setting the tripod base to an extreme operating height contributes to making the spotlight assembly topheavy and unsteady.

THE RADIANCE COLOR BOOMERANG mounts to the front of the unit on two studs (see Figure 6, Item 15) aligning to keyhole slots at the top of the housing, and is attached to the spotlight at the bottom of the housing by a thumbscrew. Make certain the thumbscrew is secured.

PROVISION IS MADE for “stowing” color frames for shipment. When stowed, the color frames are protected from breakage or other damage caused by transporting the spotlight. To enable operation of the color boomerang, detach the lower thumbscrew securing the hinged portion of the boomerang housing and fold the panels upward. This allows the color frames to drop into a “deployed” position for normal operation. An upper thumbscrew allows locking the hinged panels in the upper position. To again stow the color frames for transport, raise all six color frames to their engaged position, loosen the upper lockscrew, unfold the boomerang housing, and secure in the lower position.

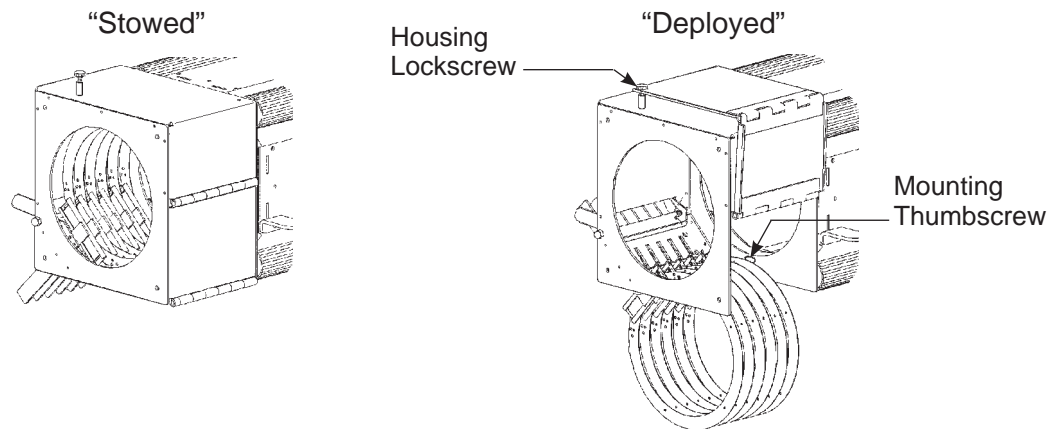

CHECK THE EQUIPMENT DATA PLATE to determine voltage and current requirements; verify correct plug and receptacle configuration. DO NOT connect the power cord to the AC line until completing the installation of the metal halide lamp.

LAMP INSTALLATION AND OPERATION

REMOVE THE REAR TOP COVER PLATE by releasing the four chromed captive quarter-turn screws and lifting the plate from the top of the lamphouse enclosure. Loosen the two thumbscrews (A) and dismount the stainless steel heat shield plate to expose the lamp socket (B & C).

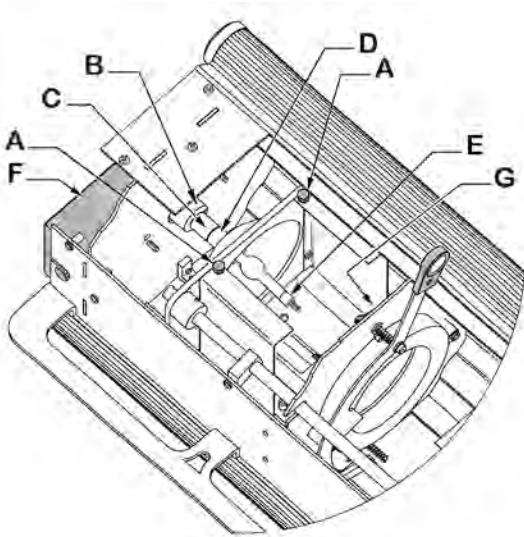

DO NOT TOUCH the quartz portion of the metal halide lamp with bare fingers! Any fingermarks accidentally placed on the lamp envelope must be removed with alcohol before lighting the bulb; skin oils will rapidly burn into the envelope material and shorten lamp life. Wear clean cloth gloves or grasp the envelope using a clean cloth towel when handling the lamp. Make certain that the threaded brass adapter (C) and the longer of the two igniter leads are firmly seated into the lamp support collet (B).

THE METAL HALIDE LAMP is polarized (positive & negative) and the larger cathode (-) end cap (D) screws into the adapter (C). Different thread sizes insure that the lamp cannot be reversed. The anode (+) end cap (E) includes a lead and thumb nut.

SECURE THE LAMP by grasping the cathode end cap by the knurled surface and turning clockwise. Tighten firmly, but use no hand tools (pliers, etc.).

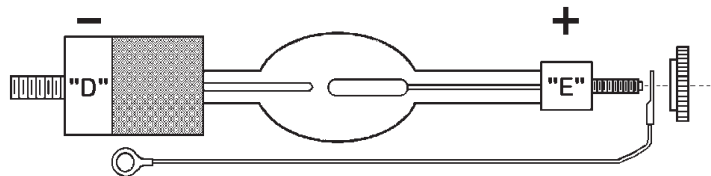

INSTALL THE RING TERMINAL at the end of the lamp lead to its connection terminal (G) and secure using the wing nut supplied. Tighten both ends of the lead securely, but do not use hand tools or apply excessive force; overtightening can damage the connection of the end caps to the quartz envelope of the lamp. Replace the upper stainless steel heat shield and the lamphouse top cover plate; secure all fasteners.

CHECK THE SPOTLIGHT DATA PLATE for the required input voltage. Plug the AC cord from the spotlight into an appropriate AC outlet. Place the POWER switch in the "ON" position and the lamp will ignite. The cooling fans in the power supply will start immediately, and the lamp cooling fan will start after a 30 second delay. The delay will allow the lamp to reach its normal operating temperature and intensity more rapidly.

LAMP INSTALLATION AND OPERATION(continued)

ONCE THE LAMP has reached full brightness, project a spot on a wall or similar vertical surface opposite the spotlight position. Loosen the two thumbscrews and remove the adjustment mechanism cover (F) from the back of the lamphouse to expose the lamp positioning controls.

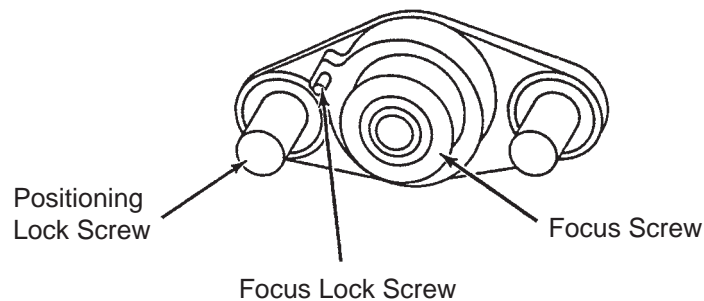

LOOSEN THE TWO positioning lock screws to permit moving the entire mechanism on the back of the lamphouse. Look at the projected spot and observe the movement of the brightest point of light inside the spot as the mechanism is moved. If no distinct bright spot is visible, rotate the focus screw in the center of the mechanism until a clearly defined “hot” spot is seen. Move the mechanism until the “hot” spot is centered in the spot. Tighten the two positioning lock screws. Rotate the focus screw to diminish the “hot” spot and create a uniform “flat” pattern of light in the projected spot.

THE 850 WATT EMARC LAMP has an expected life of 1,000 hours but may require replacement earlier if color quality degrades. To maintain a history of lamp usage, record the date and the hour meter setting whenever the lamp is replaced.

WHEN TRANSPORTING THE FOLLOW SPOT, or if the lamp may be subjected to a hard shock when moving to another location, remove the metal halide lamp from the lamphouse by reversing the installation procedures. If the positioning control section of the lamp adjustment is not changed, the lamp should be able to be replaced without repeating the aligning procedure.

OPERATION OF OPTICAL SYSTEM

THE SPOT SIZE CONTROL (ZOOM) is located on the right side of the optical system protruding from a slot in the spotlight housing. A variation of spot sizes from full flood to a small spot can be obtained by moving the zoom control from one extreme to the other. Beam intensity is increased by this optical system when reducing from flood to spot, and maximum intensity is reached when the zoom is in the extreme forward position. Depressing a thumb lever adjacent to the control permits free movement forward and back, and releasing the thumb lever locks the control in position.

ROTATING THE ZOOM KNOB operates the spot focus control. When making an adjustment, rotate the focus control until the sharpest edge is obtained on the projected spot. Moving the large lens to its center of travel and then adjusting for a sharp edge should give satisfactory results for the full movement of the lens system.

THE THREE BEAM-SHAPING CONTROL LEVERS are located immediately in front of the fade-out lever and project through the top of the optical system housing. The iris control is the center lever. When this lever is to the left (viewing the spotlight from the rear), the largest aperture is provided. Smaller apertures are obtained as the lever is moved to the right. The iris can be readily removed from the spotlight for service or replacement by pulling the lever upward and lifting the iris assembly out of the unit.

THE MAXIMUM FLOOD SPOT is obtained with the iris control lever to the left (away from operating side) for the large aperture and with the zoom control moved as far as possible toward the rear. Smaller sized spots are projected as the zoom control is moved forward. Most of the spot sizes needed will be produced with the iris in its maximum open position.

FOR A "HEAD SPOT," or any spot size smaller than can be obtained with the zoom control in its extreme forward position, shift the iris control lever to the right (toward operating side) for a smaller aperture. The iris control lever should always be returned to its extreme left position before the zoom control is again moved to obtain larger spots.

THE HORIZONTAL MASKING SHUTTER LEVER is the second (from the rear) lever projecting through the top of the optical system housing. The horizontal masking shutter blades are operated by this lever to shape the projected spot to a rectangle, strip spot, or for dousing.

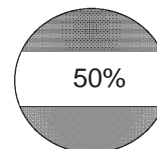

THE VERTICAL MASKING SHUTTER LEVER is the lever in front of the iris control. The vertical masking shutter blades are operated by this lever to narrow the projected spot from full width to complete douse.

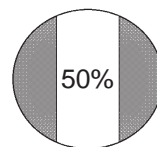

OPERATION OF OPTICAL SYSTEM (continued)

THE DISENGAGED, or fully *open* position of both masking shutter levers is to the extreme left (away from operating side). Varying degrees of masking, from fully open to complete cutoff, are obtained by moving the levers to the right (toward operating side).

THE ANGLE OF THE MASKING SHUTTER BLADES can be adjusted to compensate for the horizontal and vertical projection angle. If the spotlight is installed at an extreme house-right or house-left position, the projected edges of the masking blades may not align horizontally with the apron, or vertically with the proscenium. Remove the top access covers to expose the horizontal (rear) and vertical (front) masking blade assemblies. When the blades are in their full “open” positions, adjusting tabs are accessible above and below the horizontal blades, and to the left and right of the vertical blades. Move these tabs to position the masking blades at the desired angle.

THE FADE-OUT MECHANISM AND DOUSER CONTROL is the single lever projecting through the top of the optical system housing near the back of the unit. This lever controls the amount of light from full intensity when the lever is to the left, to complete fadeout and douse when the lever is to the extreme right.

CAUTION



ULTRAVIOLET RADIATION is emitted when the metal halide lamp is operating. Wear protective clothing and goggles or glasses when adjusting the shutter blades or performing any service with the lamphouse or optical system covers removed.



HANDLING THE FOLLOW SPOT

GENERALLY THE BEST POSITION for the operator to stand is near the center of the follow spot, on the right hand side, although the angle of tilt and the size of porthole may alter the position for the most convenient operation.

EACH OPERATOR will, after a few minutes of operation, generally develop his or her own system and preferred position for operating the follow spot.

THE VERTICAL TILT TENSION KNOB is located on the side of the housing adjacent to the fade-out lever. Counterclockwise rotation of the knob frees the tilt tension, and clockwise rotation applies tension. The individual operator can set his or her desired degree of tension.

OPERATION OF COLOR BOOMERANG

SEE THE “SETTING UP SPOTLIGHT” SECTION in the preceding pages of this manual for details of the “Stowed” and “Deployed” configurations of the Radiance boomerang. It is recommended to “stow” the color frames whenever transporting the spotlight.

THE COLOR BOOMERANG is supplied with six color holders and a “starter” set of color gels: (1) Amber, (2) Flesh Pink, (3) Daylight Blue, (4) Light Sky Blue, (5) Primary Blue, (6) Light Red. To prolong gel life, keep the darkest or most dense colors (red, green, dark blue) to the *front* of the boomerang, farthest from the bulb.

THE SIX COLOR ARMS are mounted to the side of the boomerang. To insert a color disc in the light beam, move the proper color arm downward until the latch engages. To release a color disc, raise the color release lever, or engage another color, thereby canceling the previous color.

TO REMOVE A COLOR DISC ASSEMBLY, release the arm and lift the color holder ring from the arm bracket. Install a nine-inch square section of color gel between the ring with the slide channel and the cover plate and secure using the brass fasteners supplied. Trim the excess gel material and install the assembled color frame into the boomerang. Only the six above-noted colors are supplied with the boomerang; additional colors, and color temperature reduction filters, are available from theatrical supply dealers. Specify RoscoLux® (or equivalent) high-temperature gels.

MAINTENANCE

REMOVABLE COVERS, secured with quarter-turn fasteners, are located above the lamphouse and optical system. To clean the lenses, remove the two front optical system top covers. The center lens, the back surface of the large lens, and the heat filter glass can be cleaned easily through this opening. Using a good grade of alcohol and piece of lens tissue (facial tissue can be used as a substitute), gently wipe both sides of each lens until the surfaces are clean. To clean the front surface of the large lens, slide the lens carriage to the full forward position. The front surface is then readily accessible through the front of the housing.

THE REFLECTOR should be cleaned periodically with a clean, soft lint-free cloth to remove any dust from the reflecting surface. USE NO ABRASIVES. Clean the envelope of the lamp in the same manner before replacing the lamphouse cover.

THE INSIDE of the lamphouse, lens mechanism and the fan should be cleaned periodically, depending on the dust conditions at each installation. The fan impeller blades and inlet grilles need cleaning to remove the dust buildup that accumulates over a period of time.

THE FRAMING SHUTTER DRIVE DISCS (see Figure 3, Items 12 & 13) and the roller bearings (Item 11) are lubricated with white lithium-base grease. If replacing the grease, use a similar type (typical drop point 380° F/190° C). Do not overlubricate since excessive grease will attract dust and other contaminants.

LAMPHOUSE SCHEMATIC DIAGRAM

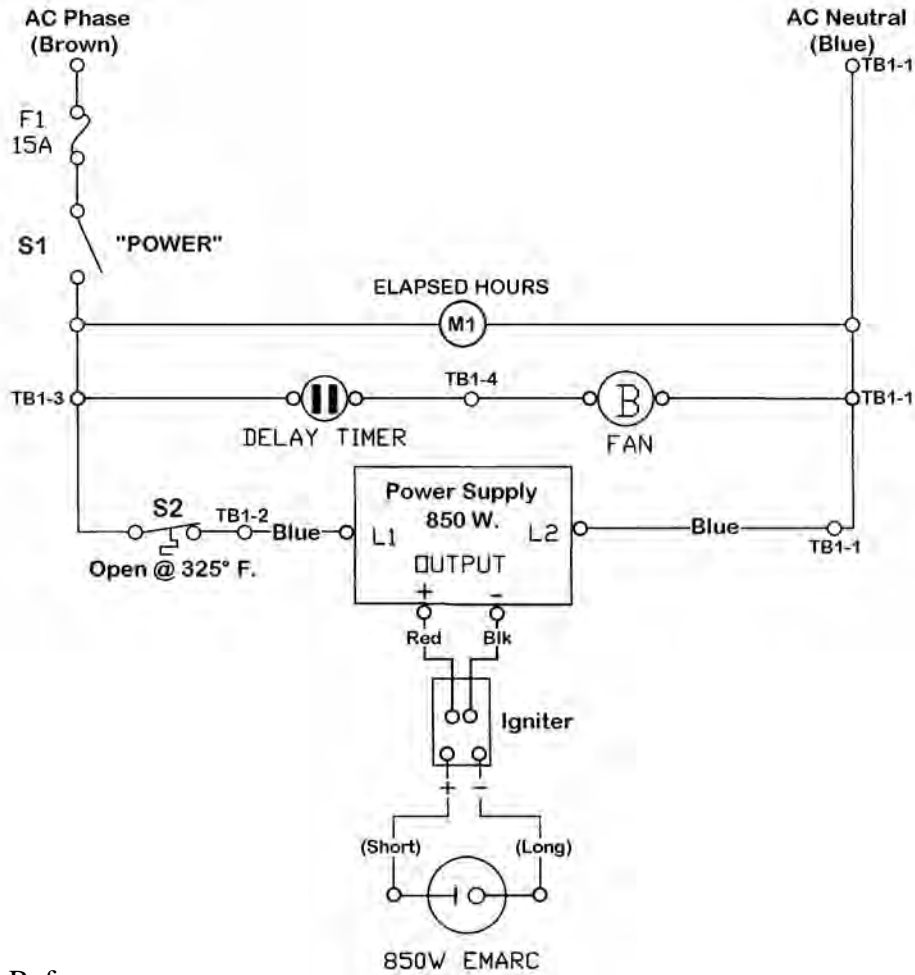

Ref.

<u>Desig.</u>	<u>Part No.</u>	<u>Description</u>
B1	72424000	Lamp Blower, 115 V.AC, 50/60 Hz.
-	7145000	Delay Timer, 115 V.AC
B1	7102002	Lamp Blower, 230 V.AC, 50/60 Hz. (Export)
-	7145001	Delay Timer, 230 V.AC
F1	8121001	Fuse, 15 A. Standard
-	2468721	Fuseholder
M1	7132003	Hour Meter
S1	1161023	Toggle Switch, ON/OFF
S2	3161134	Thermal Switch
TB1	2162003	Barrier Strip, (4) Terminal
-	7175000	Igniter
-	7201176	Negative Lead to Bulb
-	7201177	Positive Lead to Bulb
-	7198023	Power Supply

FIGURE 1

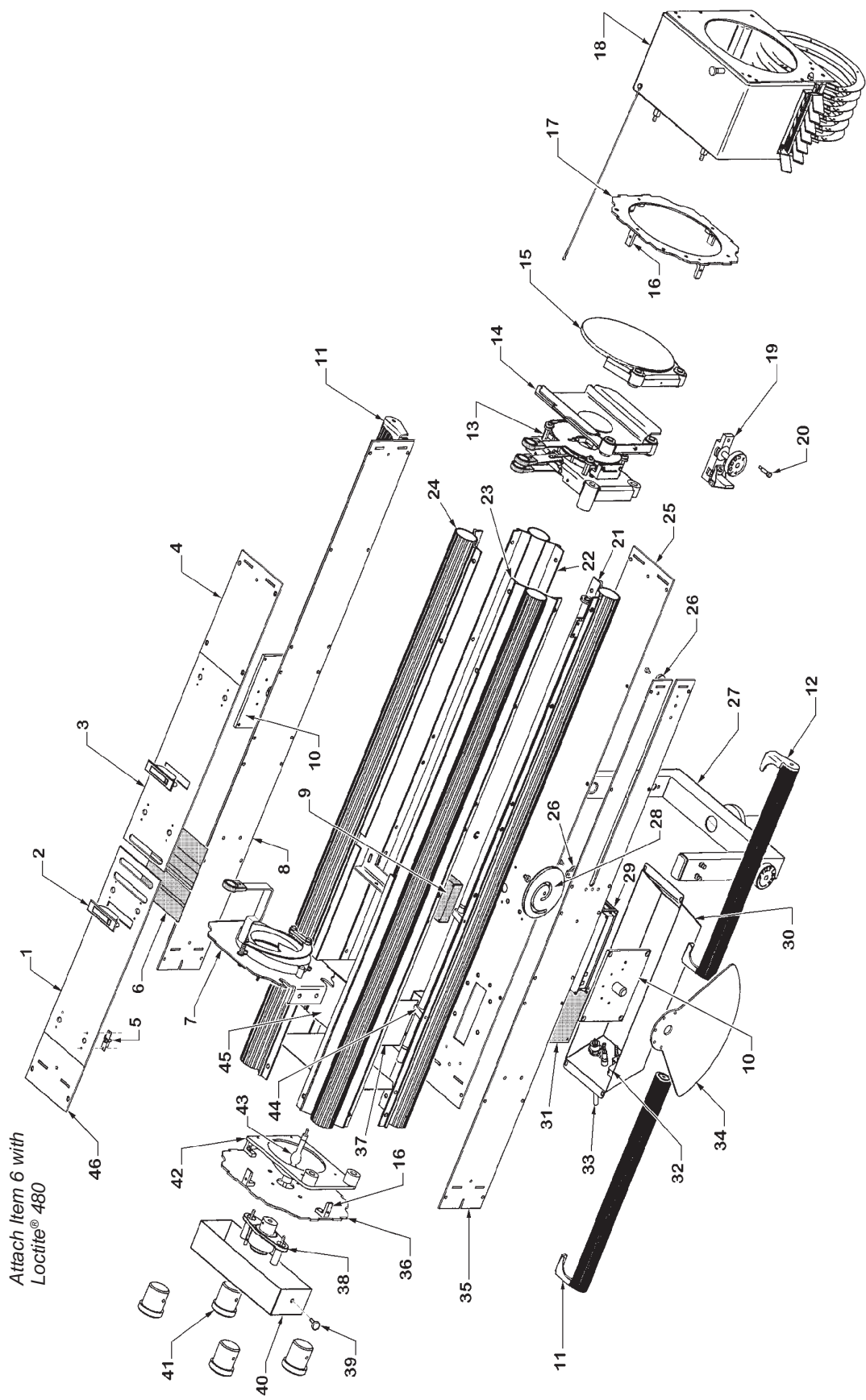

Attach Item 6 with
Loctite® 480

PARTS LIST

Figure 1

<u>Item</u>	<u>Part No.</u>	<u>Description</u>
1	7201095	Lamphouse Top Cover Plate
-	4100621	Mounting Screw, 10-32 x 5/8" Pan Head
2	23833000	Concealed Pull (2 req'd.)
3	7201096	Optical System Top Cover Plate
4	7201097	Front Top Cover Plate
5	5198423	Spring Cam Latch (8 req'd.)
6	51371000	Light Baffle, Black Rubber (6 req'd.)
7	7201108	Fade-Out/Douser Assembly (see Figure 2)
8	7201099	Cover Panel, Off-Operator Side
-	4100621	Mounting Screw, 10-32 x 5/8" Pan Head
9	7175000	Igniter Assembly
10	7201102	Yoke Pivot Bracket (2 req'd.)
11	7201198	Handle Bracket, Left
12	7201199	Handle Bracket, Right
-	7201200	Handle Shaft
-	7198025	Handle Grip, Black Rubber (order 5.25 feet)
13	7201109	Beam Shape Control Assembly (see Figure 3)
14	7201103	Rear Lens Assembly (see Figure 4)
15	7201104	Front Lens Assembly (see Figure 5)
16	7200799	End Cover Bracket (8 req'd.)
17	7201086	Front Cover Plate
18	7201110	Color Boomerang Assembly (see Figure 6)
19	7201106	Zoom/Focus Control Assembly (see Figure 7)
20	5151011	Shoulder Screw, 1/4" x 3/4" Thrd. 10-24
21	7201092	Extrusion, Operator Side, Bottom
22	7201093	Extrusion, Off-Operator Side, Bottom
23	7201091	Extrusion, Operator Side, Top
24	7201090	Extrusion, Off-Operator Side, Top
25	7201100	Bottom Cover Panel
26	25062000	Pulley (2 req'd.)
-	5220506	Shoulder Screw, Pulley Axle
-	7201181	Focus Cable & Spring Assembly (see Page 23)
27	7201105	Yoke Assembly (see Figure 8)
28	7201088	Focus Cam
-	7201170	Cam Spacer Mount (Axle)
29	7198023	Metal Halide Power Supply, 850 Watt; 115/230 V.AC, 50/60 Hz.
30	7201144	Power Supply Housing, Welded Assembly
-	7201178	Power Supply Housing, Wired Assembly (Items 30,32,33)

PARTS LIST, Figure 1 (continued)

<u>Item</u>	<u>Part No.</u>	<u>Description</u>
31	72424000	Blower (B1), 115 V.AC, 50/60 Hz.
-	7145000	Delay Timer, 115 V.AC
31	7102002	Blower (B1), 230 V.AC, 50/60 Hz. (Export)
-	7145001	Delay Timer, 230 V.AC
-	7201068	Blower Mounting Bracket
-	88253000	Blower Power Cord
32	1161023	Toggle Switch, "POWER" (S1)
33	4110041	Cord Grip
-	3140007	Power Cord, 115 V.AC, 15 A. (Domestic)
34	7201087	Tilt Lock Quadrant
-	4100629	Mounting Screw, 10-32 x 5/8" Button Head
35	7201098	Cover Panel, Operator Side
-	4100621	Mounting Screw, 10-32 x 5/8" Pan Head
36	7201085	Rear Cover Plate
37	7201067	Lamp Heat Shield, Right
-	3161134	Thermal Switch (S2; not shown)
-	7201066	Lamp Heat Shield, Left (not shown)
38	7201107	Lamp Positioning Control Assembly (see Detail below)
39	31875000	Thumbscrew (2 req'd.)
40	7201078	Lamp Adjust Cover
41	7201071	Counterweight (4 req'd.)
42	7201122	Reflector Mounting Plate
-	7201157	Reflector, 5" Diameter
43	7130000	Metal Halide Lamp, 850 Watt EmArc®
44	7200797	Slide Rod Mounting Bracket (4 req'd.)
-	7201084	Slide Rod (2 req'd.)
45	7201083	Lamp Heat Shield, Top
-	4151425	Knob, Thumbscrew
-	4100750	Screw, 10-32 x 3/4" Socket Head
46	7201094	Rear Top Cover Plate
-	4100621	Mounting Screw, 10-32 x 5/8" Pan Head

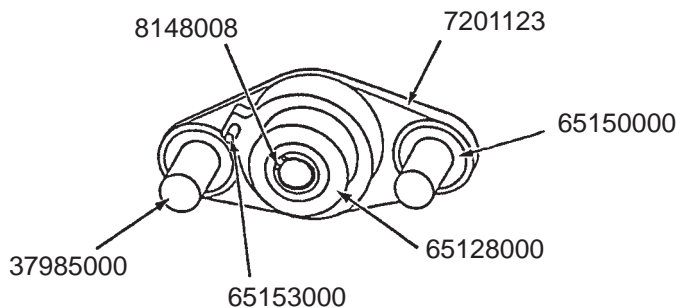

<u>Part No.</u>	<u>Description</u>
37985000	Thumb Screw (2 req'd.)
15010000	Compression Spring (2 req'd.)
65128000	Focus Screw
65150000	Fender Washer (2 req'd.)
65153000	Focus Lockscrew
65154000	Nylon Locking Ball
7201123	Casting, Adjustment Mechanism
8148008	Snap Ring, Collet Retaining

FIGURE 2

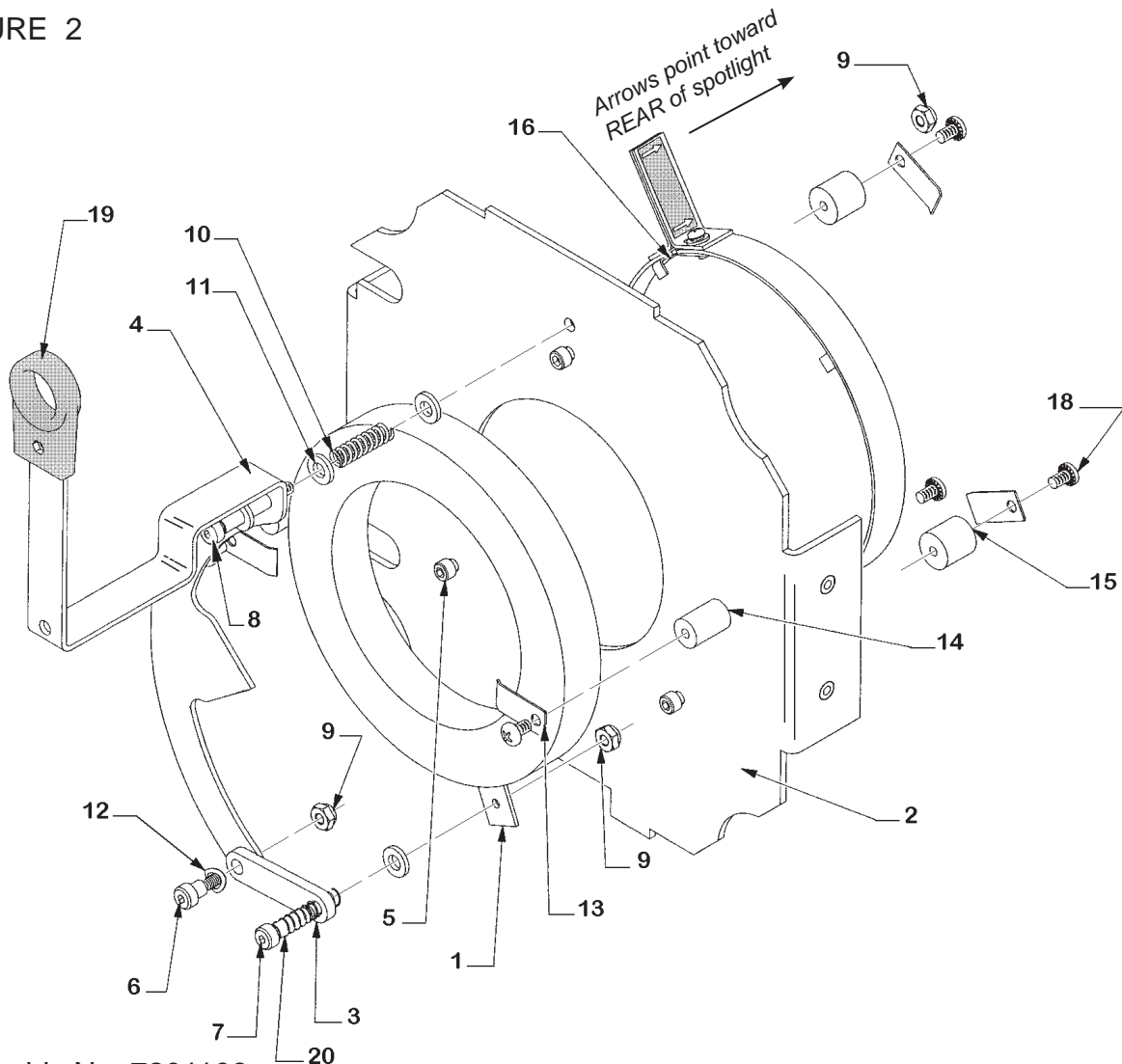

Assembly No. 7201108

<u>Item</u>	<u>Part No.</u>	<u>Description</u>	<u>Item</u>	<u>Part No.</u>	<u>Description</u>
1	7200969	Dimming Iris	11	4257104	Flatwasher, 1/4" (4 req'd.)
2	7201077	Dimmer Support Plate	12	5158041	Spring Washer, 1/4"
3	7200972	Linkage Arm	13	5240137	Spring Clip (5 req'd.)
4	7201076	Operating Lever	14	7201074	Standoff, .5" x .75" (2 req'd.)
5	4100500	Screw, 10-32 x 1/2" (3 req'd.)	15	7201075	Standoff, .625" x .625" (3 req'd.)
6	2151032	Shoulder Screw, 1/4"	16	7200504	Heat Filter & Ring Assembly
7	5151011	Shoulder Screw, 3/4"	17	3135012	Nutsert, 10-32 (4 req'd.)
8	18194000	Shoulder Screw, 1-1/4"	18	4100310	Screw, 10-32 x 5/16" (7 req'd.)
9	4118002	Hexnut, 10-24 NyLoc	19	7128001	Handle Grip
10	10260000	Compression Spring, 1-1/8"	20	5158029	Compression Spring

FIGURE 3

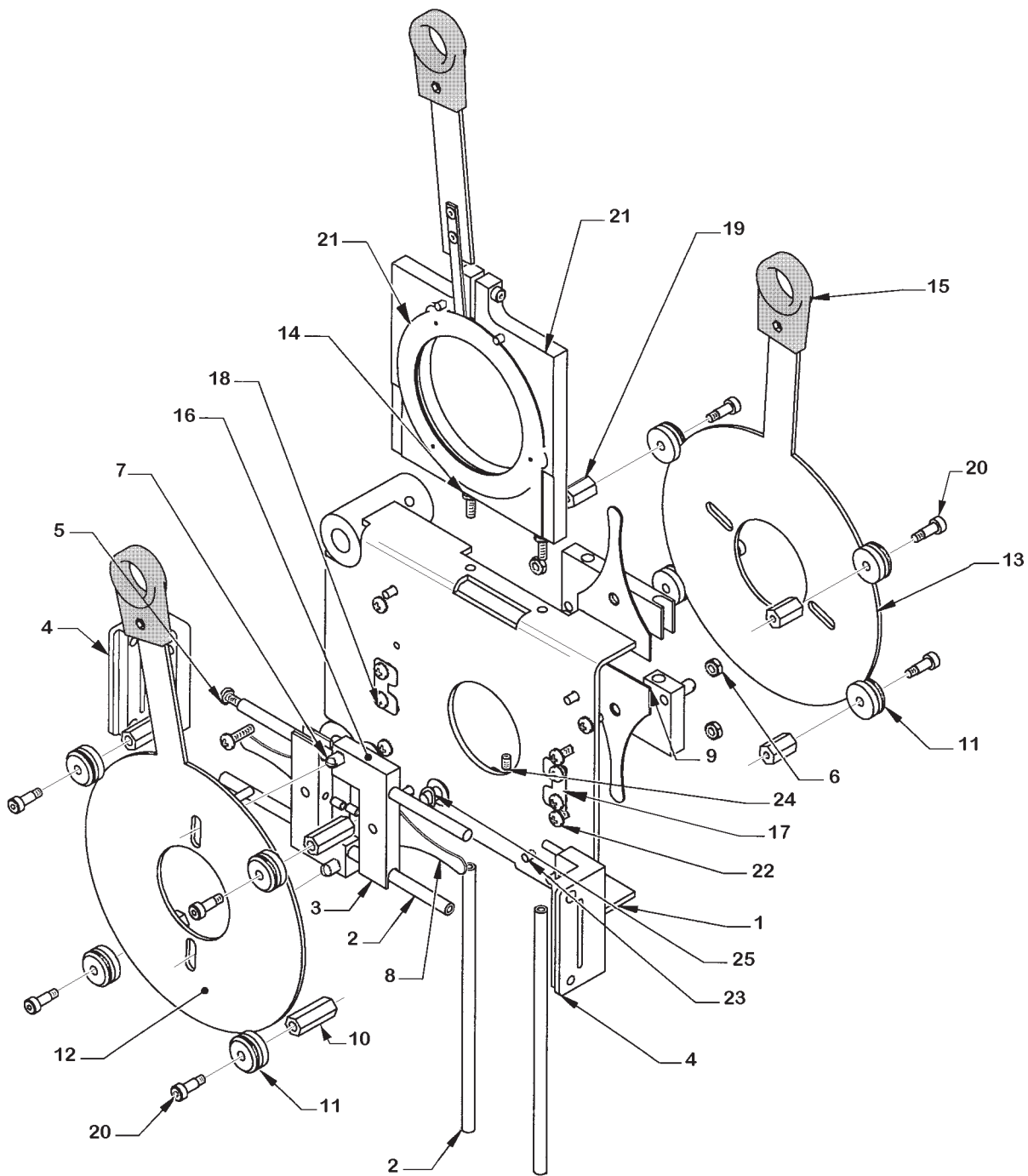

Assembly No. 7201109

PARTS LIST

Figure 3

<u>Item</u>	<u>Part No.</u>	<u>Description</u>
1	7201130	Mounting Bracket, Welded Assembly
2	7201131	Chopper Slide Rod (4 req'd.)
3	7201132	Framer Slide Block (4 req'd.)
4	7201133	Framer Shaft Bracket (2 req'd.)
5	4080624	Screw, 8-32 x 5/8" Pan Head (4 req'd.)
6	4088007	Hexnut, 8-32 K-Lock (4 req'd.)
7	7201112	Threaded Pin, 1/4" Dia. (4 req'd.)
8	7201135	Chopper Blade, Vertical (2 req'd.)
9	7201136	Chopper Blade, Horizontal (2 req'd.)
10	7198905	Standoff, 1-3/8" Long, Thrd. 8-32 (4 req'd.)
11	7201142	Roller Bearing (8 req'd.)
12	7201137	Framer Disc, Vertical
13	7201138	Framer Disc, Horizontal
14	4080506	Screw, 8-32 x 1/2" (2 req'd.)
15	7128001	Handle Grip (2 req'd.)
16	4250374	Screw, 1/4-20 x 3/8" Pan Head (4 req'd.)
17	5110004	Retaining Clamp (2 req'd.)
18	4080181	Screw, 8-32 x 3/16" Pan Head, Self-Tapping (4 req'd.)
19	7198904	Standoff, 5/8" Long, Thrd. 8-32 (4 req'd.)
20	7151007	Shoulder Screw, 3/16" x 3/8" Thrd. 8-32 (8 req'd.)
21	7201169	Iris & Mounting Plate Assembly
-	7200548	Iris (only)
22	4080754	Screw, 8-32 x 3/4" Pan Head (2 req'd.)
23	4080375	Screw, 8-32 x 3/8" Pan Head (10 req'd.)
24	4080316	Set Screw, 8-32 x 3/16" (4 req'd.)
25	5158041	Spring Washer, 1/4" (4 req'd.)

FIGURE 4

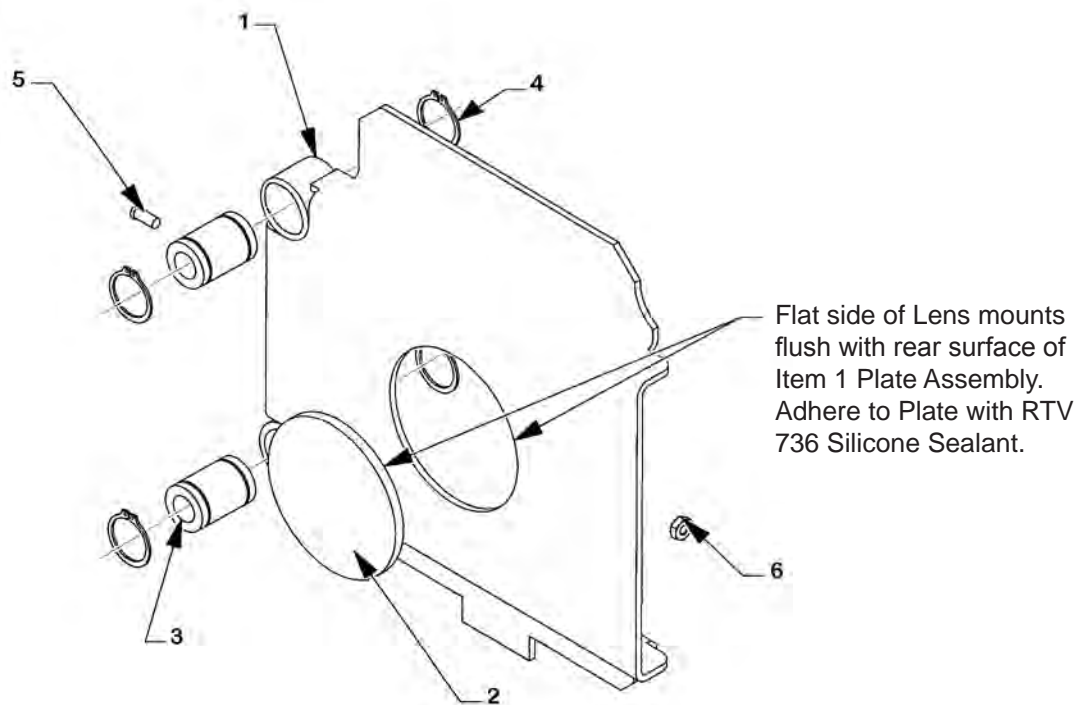

Assembly No. 7201103

<u>Item</u>	<u>Part No.</u>	<u>Description</u>
1	7201113	Plate, Welded Assembly
2	7200774	Small Lens
3	24059000	Linear Bearing (2 req'd.)
4	8148008	Retaining Ring (4 req'd.)
5	7201179	Cam Pin
6	4108007	Hexnut, 10-32 K-Lock

FIGURE 5

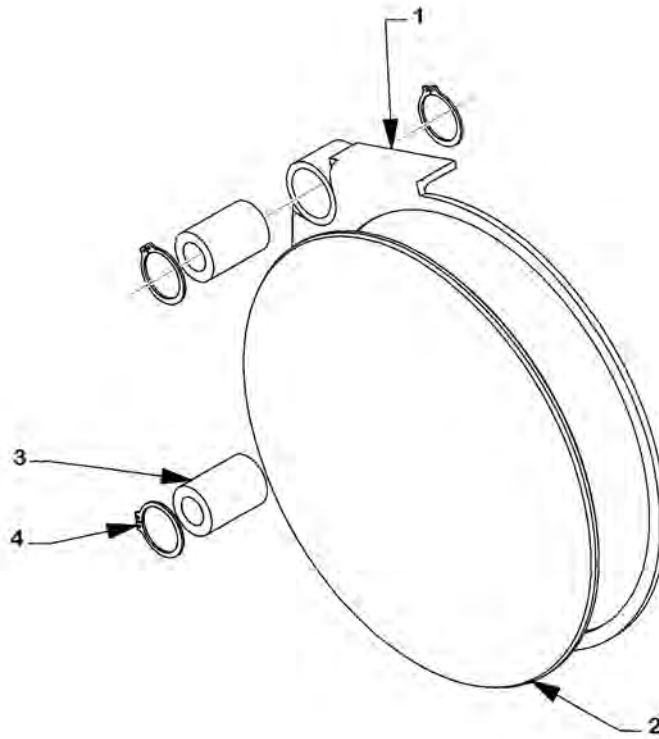

Assembly No. 7201104

<u>Item</u>	<u>Part No.</u>	<u>Description</u>
1*	7201115	Flange, Welded Assembly
2*	41305000	Large Lens
3	5104004	Linear Bearing (2 req'd.)
4	8148008	Retaining Ring (4 req'd.)

* Order 7201104 Assembly

FIGURE 6

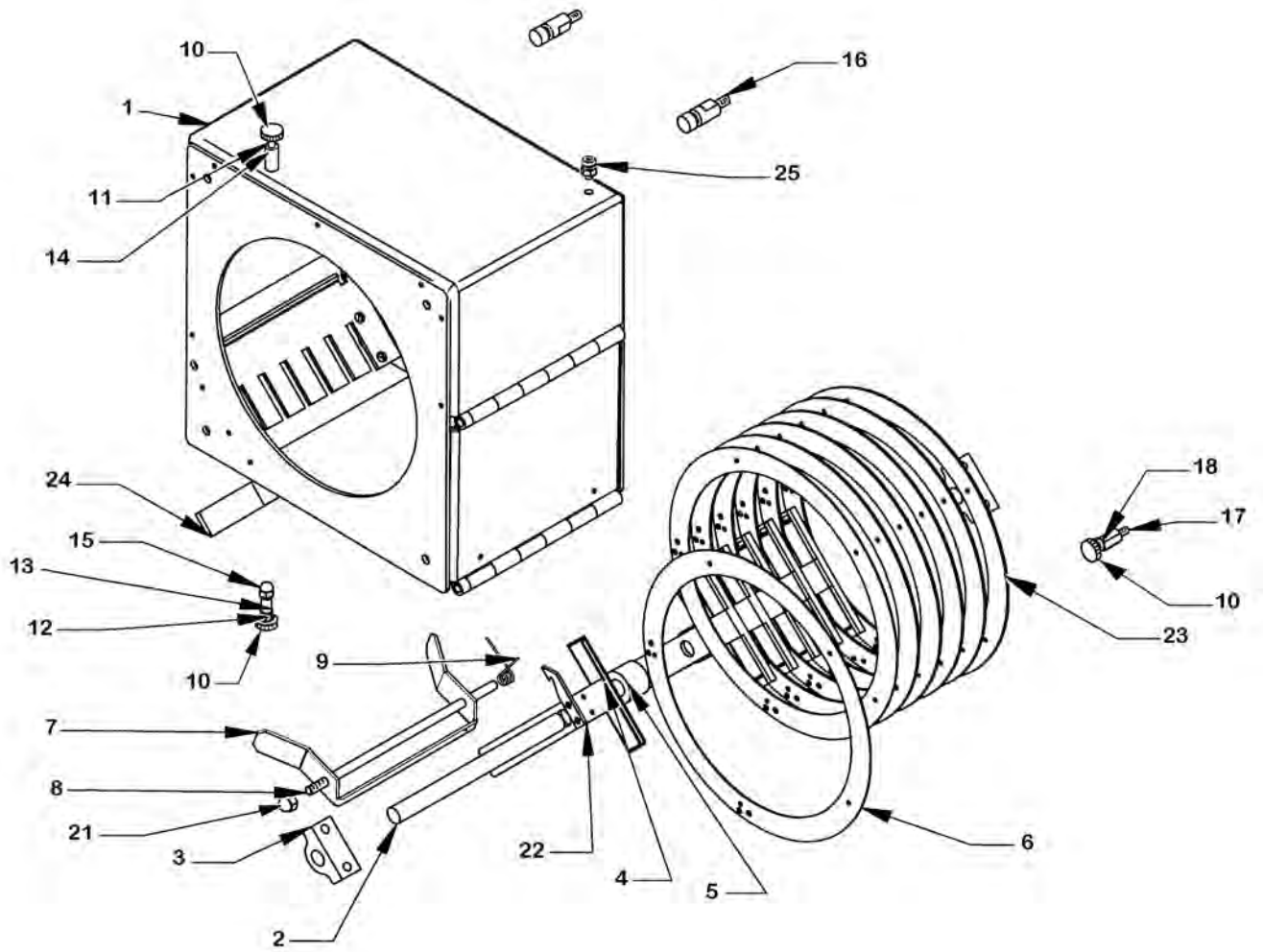

Safety Cable not shown; see Parts List

Assembly No. 7201110

PARTS LIST

Figure 6

<u>Item</u>	<u>Part No.</u>	<u>Description</u>
1	7201058	Boomerang Housing Assembly
2	7201062	Color Arm Pivot Shaft
3	7200713	Bearing Block (2 req'd.)
4	7201061	Color Arm (6 req'd.)
5	7200911	Spacer (5 req'd.)
6	51376000	Color Disc Cover Plate (6 req'd.)
-	01456000	Brass Fastener (30 req'd.)
7	7200905	Color Release Lever
8	7200930	Release Lever Pivot Shaft
9	7158004	Torsion Spring
10	4151425	Thumb Screw Knob (3 req'd.)
11	4101501	Screw, 10-32 x 1-1/2" Socket Head
12	4101000	Screw, 10-32 x 1" Socket Head
13	3135012	Nutsert, 10-32 (2 req'd.)
14	7156001	Spacer, 3/8" Dia. x 3/4" Long
15	4088008	Acorn Nut, 10-32 (3 req'd.)
16	7201060	Keyhole Standoff, 1/2" Dia. (2 req'd.)
17	4198096	Standoff, 3/4" Thrd. 10-32
18	4107106	Bolt Retainer Push Nut
19	4100374	Screw, 10-32 x 3/8" Socket Head
20	3135014	Nutsert, 1/4-20
21	4258008	Acorn Nut, 1/4-20
22	51396000	Color Arm Catch Hook (6 req'd.)
-	4080250	Mounting Screw, 8-32 x 1/4" Pan Head (12 req'd.)
23	51928000	Color Disc Slide Channel (6 req'd.)
24	51505000	Rocker Pad (2 req'd.)
25	4100371	Screw, 10-32 x 3/8" Pan Head
26	4250508	Screw, 1/4-20 x 1/2" Pan Head (4 req'd.)

NOT SHOWN

3198178	Safety Cable (see Figure 1, Item 18)
3198643	Carabiner Clip, Safety Cable

FIGURE 7

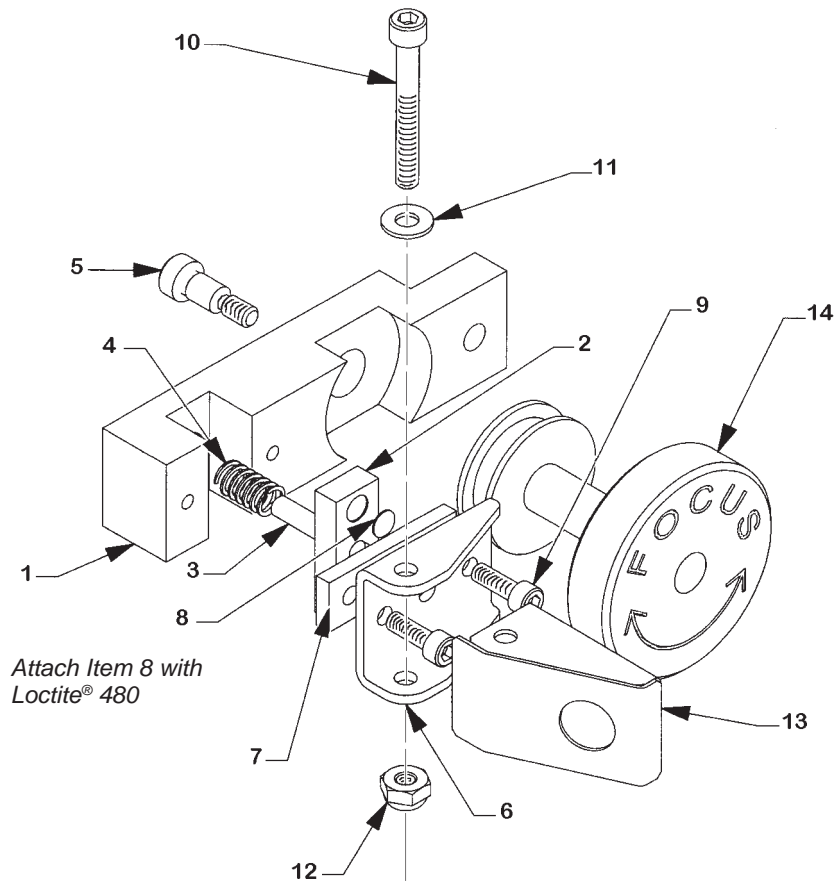

Assembly No. 7201106

<u>Item</u>	<u>Part No.</u>	<u>Description</u>	<u>Item</u>	<u>Part No.</u>	<u>Description</u>
1	7201116	Lock Carriage	8	4198128	Bumpon (2 req'd.)
2	7200857	Brake Block	9	4080502	Screw, 8-32 x 1/2" (2 req'd.)
3	2137014	Dowel Pin, 1-1/4" x 3/16" Dia.	10	4102500	Lock Release Pivot Bolt
4	2158040	Compression Spring	11	4107100	Flatwasher, #10 SAE
5	4151755	Shoulder Screw, 3/8"	12	4108002	Hexnut, 10-32 NyLoc
6	7200854	Lens Lock Bracket	13	7200962	Release Lever Assembly
7	7200963	Spacer	14	7201117	Focus Knob

FIGURE 7

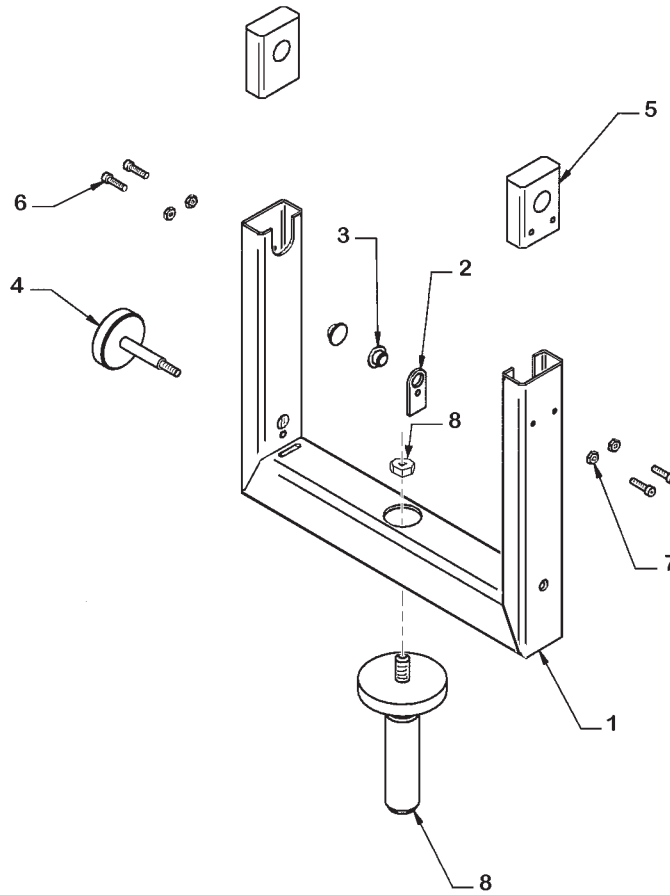

Assembly No. 7201105

<u>Item</u>	<u>Part No.</u>	<u>Description</u>
1	7201158	Yoke, Welded Assembly
2	7201162	Brake Shoe
3	7201163	Brake Plug (2 req'd.)
4	7201164	Locking Knob Assembly
5	4151755	Shoulder Screw, 3/8"
6	7200854	Lens Lock Bracket
7	7200963	Spacer
8	7201161	Spigot & Hexnut

REPLACEMENT OF FOCUS CABLE ASSEMBLY

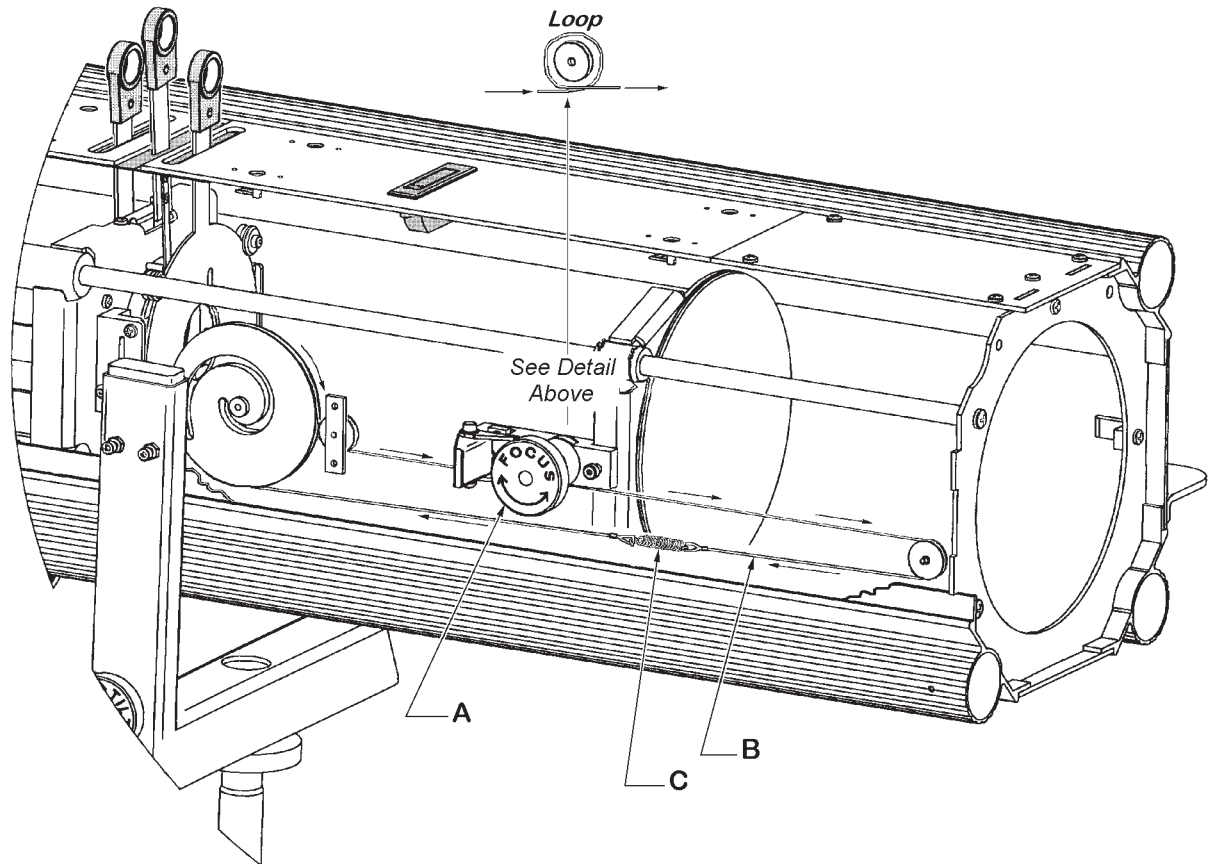

The Focus Cable Assembly 7201181 consists of the wire rope (B) cut to length and terminated with loops, and the expansion spring (C).

1. Dismount the knob and pulley assembly (A) from 7201106 Zoom/Focus Assembly (see Figure 7). Loop the wire rope (B) around the pulley as shown, and replace the knob and pulley.
2. Route the wire rope as shown. Connect loops using the expansion spring (C) and pull wire rope over front pulley. Position the spring near center of loop to prevent its riding over pulley or cam.

