

SEL10

Lamphead & Base Assembly

for Equipment Type MLS210

Rev. July 2001

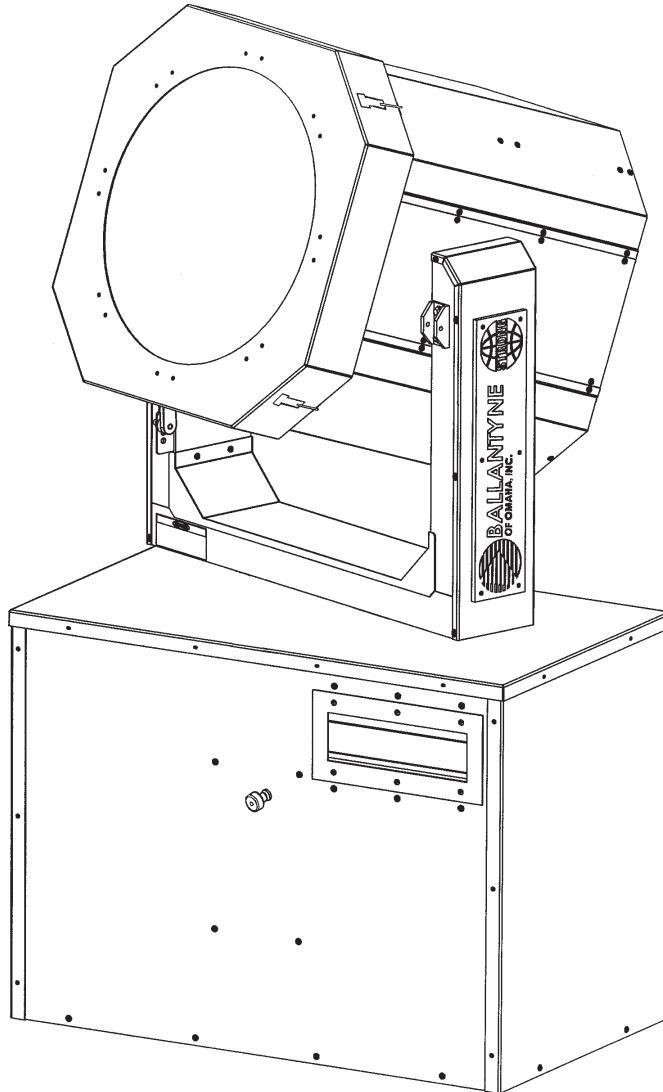

Operator's Manual & Parts List



a division of Ballantyne of Omaha, Inc.
4350 McKinley Street • Omaha, Nebraska 68112 USA
Tel 402/453-4444 • Fax 402/453-7238

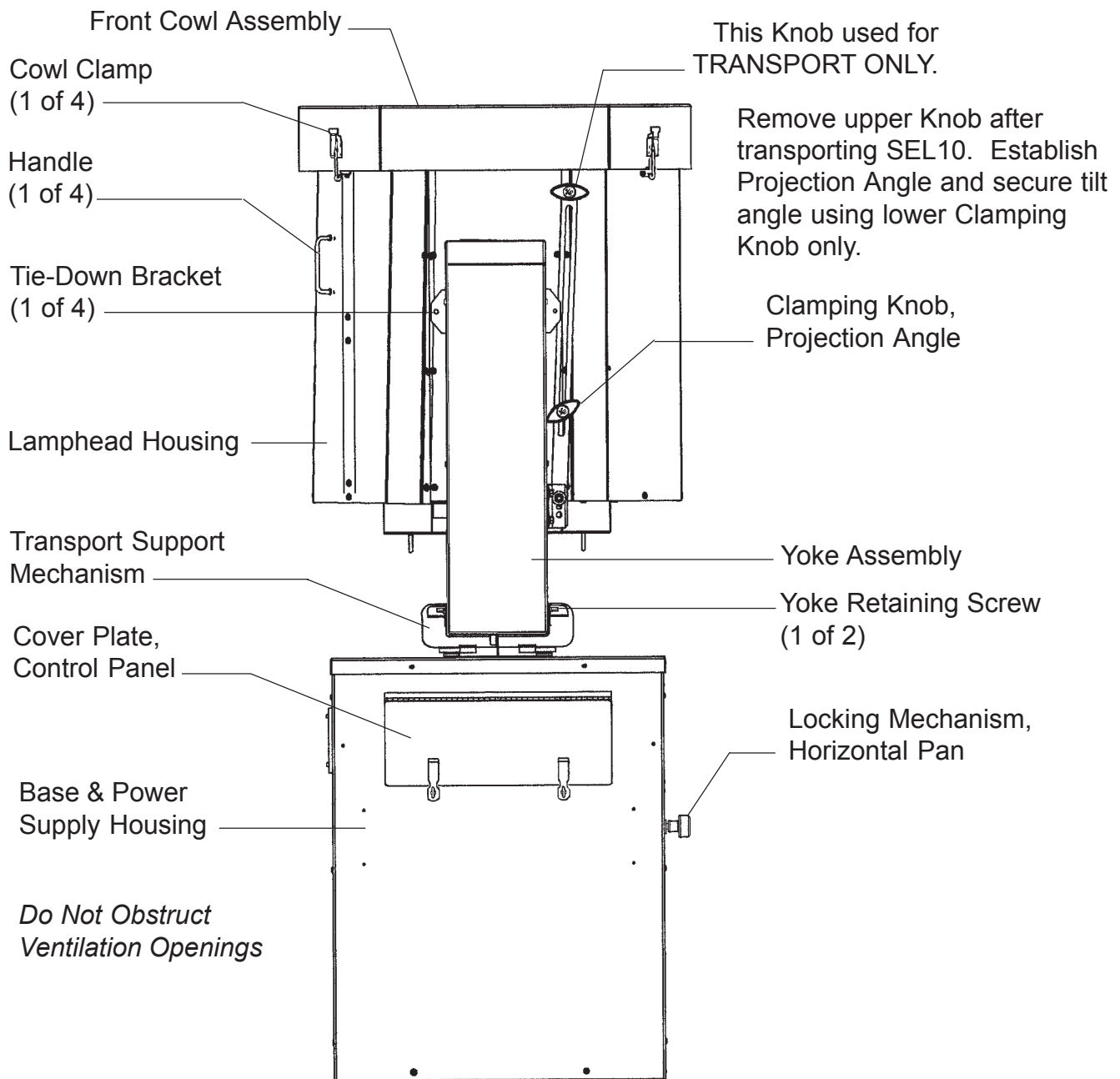

SEL10 LAMPHEAD & BASE ASSEMBLY
Secured for Transport

PREFACE

The **SEL10** is a 10,000 watt xenon searchlight mounted on a rotating yoke. The angle and direction of light projection are independently adjustable on a 360° horizontal arc and through 90° of vertical tilt, and locks in the desired position. The base assembly is a weathertight enclosure containing the xenon power supplies. The unit is mounted on a trailer and powered by a diesel engine-generator unit.

Continuous high output performance is assured by means of a coated, 30 inch precision electroformed, parabolic nickel reflector. The reflector is carefully positioned at the factory and requires no operator adjustment. The light source is a 10,000 watt xenon bulb which can operate in any position (vertical to horizontal) and maintains a constant color temperature of 5600° Kelvin. A squirrelcage blower is mounted in the lamphead to provide continuous forced-air cooling while the bulb is in operation. The bulb is warranted for 500 hours. It is recommended to replace the bulb upon expiration of the warranty.

Operator controls mounted to the instrument panel include a SYSTEM ON/OFF switch and a STRIKE (“emergency ignite”) switch to bypass the autostrike circuit. A FOCUS switch controls an AC motor inside the lamphead which moves the bulb inside the reflector to adjust focus. An hour meter, located adjacent to the switches, records the elapsed time of xenon bulb operation. A volt meter and ammeter monitor xenon bulb operation.

Direct current for the xenon bulb is derived from two high reactance xenon power supplies mounted in the base of the unit. All models are designed for 50/60 Hertz operation, and are available in varying AC input types, depending upon the configuration of the main power transformer. Check the Equipment Data Plate to determine the exact AC requirement prior to installation.

Coarse and fine taps are easily set to regulate the DC current to the xenon lamphead. Some models of these power supplies have the capability of overdriving the xenon bulb; carefully check the power requirements specified by the bulb manufacturer and do not exceed the maximum current stated.

The two power supplies, wired in parallel, produce the high open circuit (“no load”) voltage required for bulb ignition, and, after ignition, the filtered low voltage current to sustain operation. The bridge rectifiers utilize silicon diodes as the power conversion elements. The diodes are mounted to oversized heat sinks to disperse the heat generated by normal operation. Internally wired squirrelcage blowers provide additional forced-air cooling of each power supply. Thermal switches act as safety interlocks to shut down the power supplies and protect the rectifier diodes in case temperatures reach excessive levels.

INSTALLATION

Check all equipment Data Plates and make certain that the generator unit conforms to the input requirements of the main transformers of the xenon power supplies. Refer to the instructions furnished separately for generator start-up procedures. Set generator output to 208/230 V.AC, 60 Hz. All output connections to the xenon power supplies and lampheads are factory prewired.

Remove the (2) end panels from the base assembly to gain access to the tap terminal boards of the xenon power supplies. Remove the upper clamping knob (“TRANSPORT ONLY”) from the projection angle locking arm. Loosen the (2) set screws securing the yoke position and fold the hinged plate of the transport support mechanism down. Loosen the projection angle clamping knob and lower the lamphead to a horizontal position. Retighten the clamping knob to secure the lamphead. Release the (4) cowl clamps and remove the front cowl assembly.

OPERATOR'S CONTROL PANEL

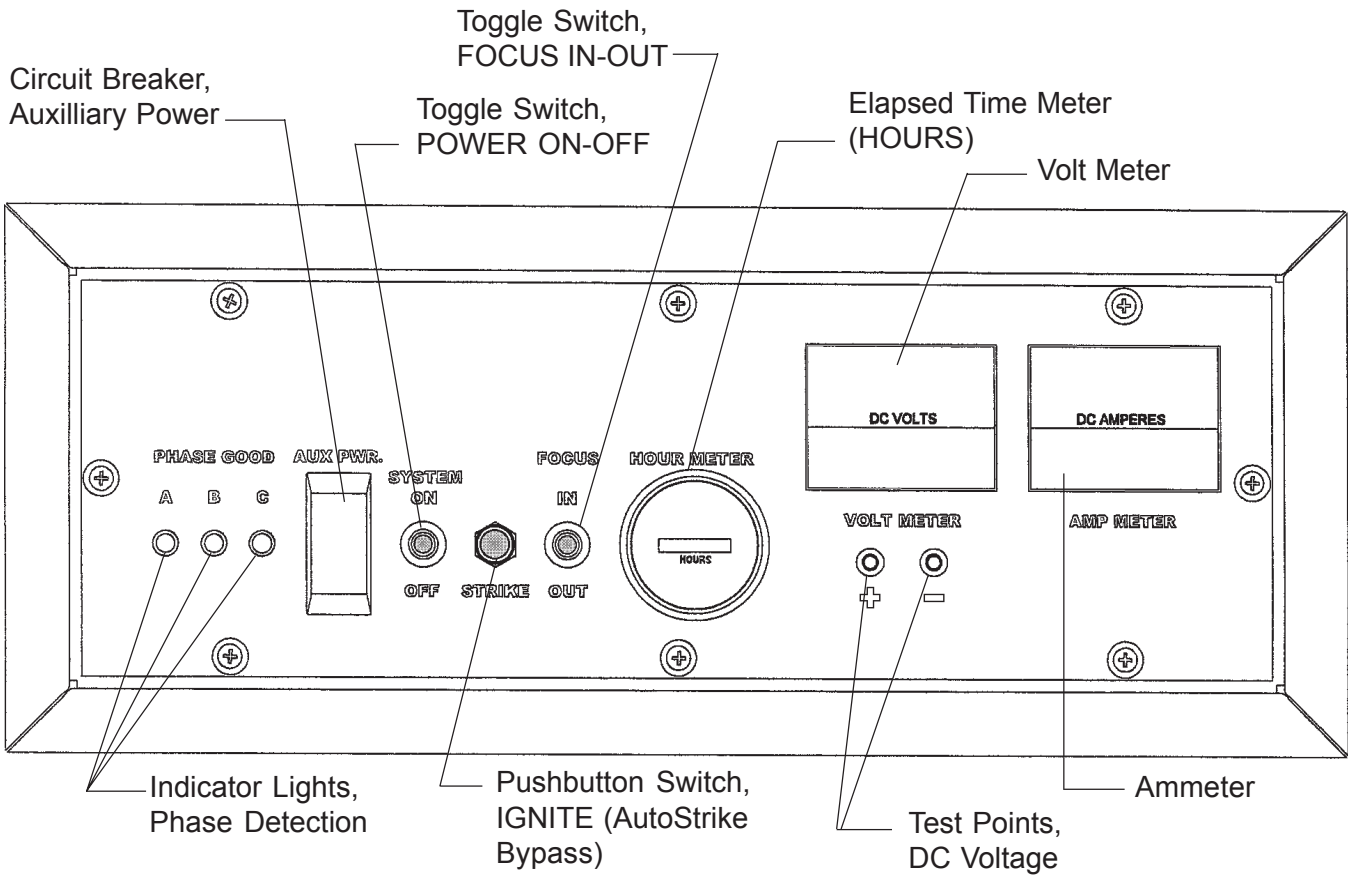

INSTRUCTIONS FOR REMOVING AND INSTALLING A TYPE "XT" XENON BULB IN A SEL10 FIXTURE

NOTE

FAMILIARIZE YOURSELF WITH THE LOCATION AND IDENTIFICATION OF THE COMPONENTS OF THIS SYSTEM AND ALSO THE NORMAL OPERATION OF THE SYSTEM BEFORE ATTEMPTING ANY ADJUSTMENT OR SERVICE.

NOTE

COMPLETELY READ THROUGH AND HAVE A GOOD UNDERSTANDING OF THE PROCEDURES BEFORE ATTEMPTING TO SERVICE THIS SYSTEM. FAILURE TO DO SO MAY RESULT IN FATAL INJURY OR EQUIPMENT DAMAGE.

NOTE

THE LAMPHEAD SHOULD BE LOCKED IN THE HORIZONTAL POSITION DURING ANY SERVICE PROCEDURES.

WARNING

DISCONNECT POWER SOURCE BEFORE SERVICING THIS EQUIPMENT.

WARNING

A PROTECTIVE JACKET, FULL FACE SHIELD, AND PROTECTIVE GLOVES MUST BE WORN AT ALL TIMES WHEN THE LAMPHEAD IS OPENED WITH A BULB INSTALLED, OR WHEN HANDLING THE XENON BULBS. SERIOUS INJURY MAY OCCUR IF PROPER SAFETY PRECAUTIONS ARE NOT OBSERVED. READ ALL ENCLOSED INSTRUCTIONS AND INFORMATION SHEETS BEFORE HANDLING THE BULB.

WARNING

NEVER OPERATE A FIXTURE WITH AN EXPOSED BULB! THERE IS AN EXTREME DANGER OF SEVERE BURNS TO EXPOSED SKIN AND EYES FROM THE ULTRAVIOLET LIGHT EMITTED FROM THE EXPOSED BULB. DAMAGE CAN OCCUR IN AS LITTLE AS 30 SECONDS OF EXPOSURE. THERE IS ALSO AN ADDITIONAL DANGER FROM FLYING QUARTZ IF AN EXPOSED BULB EXPLODES!

EQUIPMENT REQUIRED

- 1. PROTECTIVE SAFETY EQUIPMENT KIT**
- 2. 7/16" END WRENCH OR SOCKET**
- 3. ALLEN WRENCH 5/32"**

DISASSEMBLY PROCEDURE

PRIOR TO BULB INSTALLATION:

1. RELEASE THE (4) FASTENERS LOCATED AT THE SMALL SIDES OF THE COWL. PULL FORWARD TO REMOVE THE COWL ASSEMBLY.
2. REMOVE THE (2) BRASS BOLTS CONNECTING THE SHORT LEADS TO THE FRONT BULB HOLDER USING A 7/16" WRENCH.
3. REMOVE THE CENTER MOUNTING SCREW, WASHER, AND SPRING FROM THE SPIDER (SEE FIGURE 4, ITEMS 2, 3, 4) USING A 5/32" ALLEN WRENCH WHILE SUPPORTING THE FRONT BULB HOLDER SO THAT IT DOES NOT FALL WHEN THE SCREW IS REMOVED.
4. REMOVE THE BULB HOLDER FROM THE FIXTURE.
5. TO DISASSEMBLE THE FRONT BULB HOLDER, REMOVE THE (2) CLAMP RETAINING SCREWS LOCATED ON THE SIDE OF THE LAMP SWIVEL HUB USING A 5/32" ALLEN WRENCH, AND REMOVE THE CLAMP.

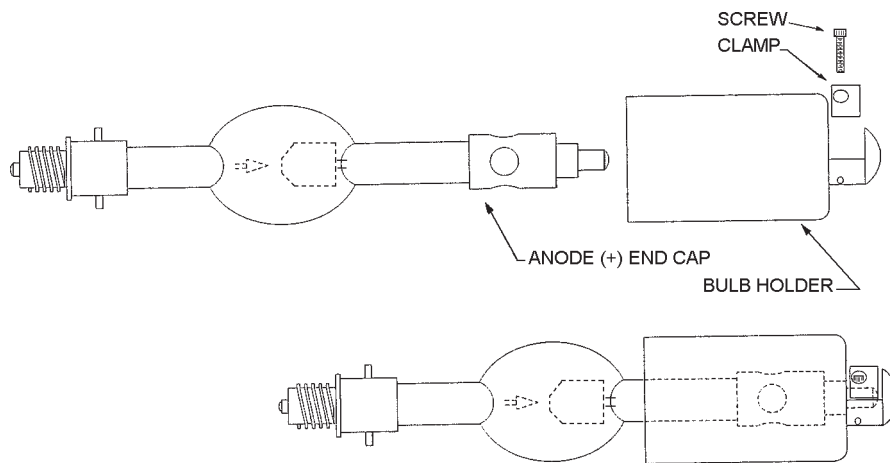

ASSEMBLY PROCEDURE

WARNING

DO NOT REMOVE THE PROTECTIVE COVER FROM THE BULB UNTIL INSTRUCTED TO DO SO!

WARNING

DO EXERT ANY FORCE ON THE QUARTZ PORTION OF THE BULB AT ANY TIME!

NOTE

IF THE FRONT BULB HOLDER HAS NOT BEEN DISASSEMBLED, SEE THE LAST STEPS IN THE APPROPRIATE DISASSEMBLY INSTRUCTIONS.

1. UNTIE THE CORD ON THE ANODE (+) END OF THE PROTECTIVE COVER. DO NOT REMOVE THE COVER AT THIS TIME!
2. FASTEN FRONT BULB HOLDER TO THE BULB BY PLACING THE ANODE END (LARGE ELECTRODE) OF THE BULB IN THE BULB HOLDER AND ALIGNING THE STUD ON THE END OF THE BULB FERRULE WITH THE CHANNEL IN THE NOSE OF THE BULB HOLDER BODY. SLIDE THE BULB COMPLETELY DOWN THE CHANNEL AS FAR AS IT WILL GO.

WARNING

DO NOT APPLY ANY PRESSURE ON THE BULB WHILE REASSEMBLING THE FRONT BULB HOLDER!

3. REPLACE THE CLAMP AND REINSTALL THE (2) CLAMP RETAINING SCREWS LOCATED ON THE SIDE OF THE BULB SWIVEL HUB USING A 5/32" ALLEN WRENCH.
4. INSTALL THE BULB INTO THE FIXTURE BY CAREFULLY INSERTING THE CATHODE (-) END OF THE BULB THROUGH THE OPENING IN THE REFLECTOR. DO NOT STRIKE THE SURFACE OF THE REFLECTOR.
5. INSERT THE END OF THE BULB FERRULE INTO THE OPENING IN THE BULB LAMP HOLDER RECEIVER BLOCK AND ALIGN THE THREADS BY TURNING THE BULB COUNTERCLOCKWISE UNTIL THE BULB THREADS DROP INTO THE RECEIVER THREADS.

CAUTION

DO NOT OVERTIGHTEN THE BULB IN THE RECEIVER BLOCK AS THIS MAY CAUSE THE BULB TO "FREEZE" IN THE RECEIVER BLOCK, MAKING IT DIFFICULT TO REMOVE. TIGHTEN THE BULB JUST ENOUGH TO APPLY SPRING PRESSURE TO THE THREADS BUT NOT SO MUCH AS TO BOTTOM OUT THE LAMP FERRULE COMPLETELY AGAINST THE RECEIVER BLOCK.

6. GENTLY ROTATE THE BULB CLOCKWISE UNTIL RESISTANCE IS FELT.
7. AT THIS POINT, THE BULB SHOULD BE IN CONTACT WITH THE SPRING PLUNGER ASSEMBLIES. GENTLY TURN THE BULB AN ADDITIONAL 1/16 - 1/8 OF A TURN TO LOAD THE THREADS WITH THE SPRING PLUNGERS.
8. SECURE THE FRONT BULB HOLDER TO THE SPIDER WITH THE SHOULDER BOLT, SPRING, AND WASHER THAT WAS REMOVED DURING DISASSEMBLY.
9. CONNECT THE (2) SHORT LEADS FROM THE SPIDER TO THE FRONT BULB HOLDER USING THE TWO BRASS BOLTS AND WASHERS THAT WERE REMOVED DURING DISASSEMBLY.

NOTE

ANY TYPE OF ALCOHOL IS SUITABLE FOR CLEANING THE BULB EXCEPT FOR ALCOHOL THAT HAS BEEN DENATURED USING PETROLEUM PRODUCTS SINCE THE DENATURING AGENT WILL LEAVE A RESIDUE ON THE QUARTZ ENVELOPE.

10. REMOVE THE PROTECTIVE COVER FROM THE BULB AND CLEAN THE QUARTZ PORTION OF THE BULB COMPLETELY WITH ALCOHOL.
11. THE INSTALLATION IS NOW COMPLETE. REPLACE THE FRONT COWL AND TEST THE BULB.
12. LOG THE HOUR METER READING AT INSTALLATION.
13. PERFORM THE OUTPUT POWER ADJUSTMENT PROCEDURES. THE 10000W-XT BULB IS DESIGNED FOR OPERATION WITHIN THE FOLLOWING RANGE:

**165-210 AMPERES
50-54 VOLTS DC**

NOTE: OPERATION *BELOW* 165 AMPERES WILL *NOT* PROLONG BULB LIFE, BUT RATHER WILL DEGRADE BULB IGNITION BY DAMAGING THE CATHODE TIP.

14. PERFORM THE FOCUS AND X-Y PROCEDURES.

DISASSEMBLY PROCEDURE

IF THERE IS A LAMP IS INSTALLED IN THE FIXTURE:

1. RELEASE THE (4) FASTENERS LOCATED AT THE SMALL SIDES OF THE COWL. PULL FORWARD TO REMOVE THE COWLING.

CAUTION

DO NOT PLACE ANY FORCE ON THE LAMP WHILE REPLACING THE PROTECTIVE WRAPPER!

2. WRAP THE BULB SECURELY IN THE PROTECTIVE WRAPPER THAT THE BULB WAS ORIGINALLY SHIPPED WITH.
3. REMOVE THE (2) BRASS BOLTS CONNECTING THE SHORT LEADS TO THE FRONT BULB HOLDER USING A 7/16" WRENCH.
4. REMOVE THE CENTER MOUNTING SCREW, WASHER, AND SPRING (SEE FIGURE 4, ITEMS 2, 3, 4) FROM THE SPIDER USING A 5/32" ALLEN WRENCH WHILE SUPPORTING THE FRONT BULB HOLDER SO THAT THE BULB DOES NOT DROP WHEN THE MOUNTING SCREW IS REMOVED.

WARNING

DO NOT EXERT EXCESSIVE FORCE ON THE BULB WHILE UNSCREWING IT FROM THE REAR BULB HOLDER! THE BULB SHOULD RELEASE FROM THE REAR BULB HOLDER WITH A VERY LIGHT COUNTERCLOCKWISE ROTATION. IF THIS DOES NOT HAPPEN, SEE THE PROCEDURE FOR REMOVING A "FROZEN" BULB.

5. REMOVE THE BULB BY LIGHTLY PUSHING BACK ON THE BULB TO MOVE THE REAR BULB HOLDER TO ITS REAR MOST POSITION WHILE LIGHTLY TURNING THE BULB IN A COUNTERCLOCKWISE ROTATION. THE BULB WILL RELEASE FROM THE REAR BULB HOLDER IN APPROXIMATELY 1½ COMPLETE TURNS.
6. REMOVE THE BULB WITH THE FRONT BULB HOLDER ATTACHED FROM THE FIXTURE. PLACE IT ON A STABLE WORKING SURFACE FOR THE REMOVAL OF THE FRONT BULB HOLDER.
7. TO REMOVE THE FRONT BULB HOLDER FROM THE BULB, REMOVE THE (2) CLAMP RETAINING SCREWS LOCATED ON THE SIDE OF THE BULB SWIVEL HUB USING A 5/32" ALLEN WRENCH AND REMOVE THE CLAMP.
8. REMOVE THE BULB HOLDER FROM THE BULB AND PLACE THE BULB INTO ITS SHIPPING CONTAINER FOR SAFEKEEPING. RESECURE THE PROTECTIVE WRAPPER IF NECESSARY.

REMOVING A "FROZEN" BULB

1. REPLACE THE FRONT BULB HOLDER RETAINING BOLT TO SUPPORT THE FRONT OF THE BULB WHILE FREEING THE BULB FROM THE REAR BULB HOLDER.

DO EXERT ANY FORCE ON THE QUARTZ PORTIONS OF THE BULB WHILE ATTEMPTING TO FREE IT FROM THE REAR LAMP HOLDER!

2. REACH THROUGH THE OPENING IN THE REAR OF THE REFLECTOR AND GRASP THE BULB'S END CAP (THE REAR METAL FERRULE). WHILE LIGHTLY PUSHING THE BULB BACK INTO THE RECEIVER BLOCK, TURN THE BULB IN A COUNTERCLOCKWISE DIRECTION UNTIL THE BULB BEGINS TO ROTATE FREELY.

REMOVING A "FROZEN" BULB (CONTINUED)

- ONCE THE BULB IS FREE, DO NOT YET REMOVE IT FROM THE REAR LAMP HOLDER.
- RETURN TO STEP 5 OF THE PRECEDING SECTION.

OUTPUT POWER ADJUSTMENT PROCEDURES

NOTE

FAMILIARIZE YOURSELF WITH THE LOCATION AND IDENTIFICATION OF THE COMPONENTS OF THIS SYSTEM AND ALSO THE NORMAL OPERATION OF THE SYSTEM BEFORE ATTEMPTING ANY ADJUSTMENT OR SERVICE.

NOTE

COMPLETELY READ THROUGH AND HAVE A GOOD UNDERSTANDING OF THE PROCEDURES BEFORE ATTEMPTING TO SERVICE THIS SYSTEM. FAILURE TO DO SO MAY RESULT IN FATAL INJURY OR EQUIPMENT DAMAGE.

WARNING

DISCONNECT POWER SOURCE BEFORE SERVICING THIS EQUIPMENT.

EQUIPMENT REQUIRED

- SCREWDRIVER, Flat Blade, Large
- SCREWDRIVER, #2 Phillips

ADJUSTMENT INSTRUCTIONS

- Remove lower access covers from the ends of the base enclosure by removing the (6) screws along the sides of each panel with a Phillips screwdriver.
- Note the location and settings of the power supply adjustment taps.

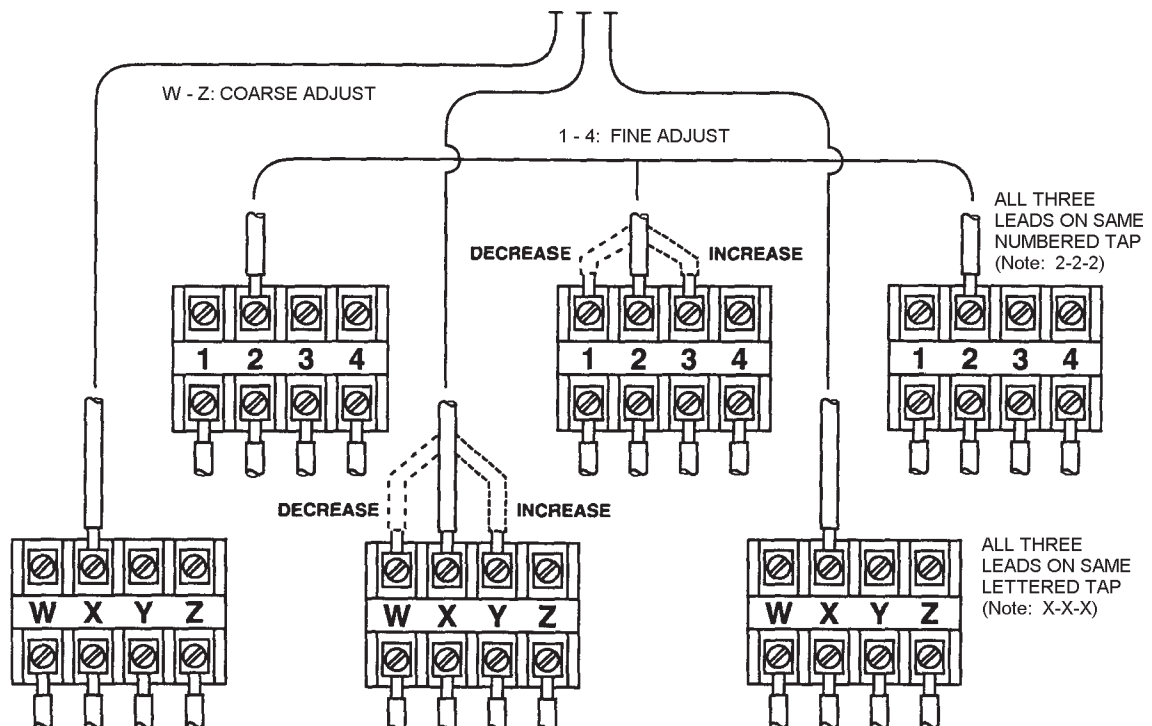

ADJUSTMENT INSTRUCTIONS (continued)

3. Ignite the xenon bulb and check the current. Allow (30) seconds for the current to stabilize and provide an accurate reading. A new 10000W-XT bulb should be first operated at the nominal current level of **180-185** amperes. If the current is *not* within the desired range, extinguish the bulb. It will be necessary to increase or decrease the DC output.
4. *Fine adjustment* of the DC current is made to the *NUMBERED* taps found on the upper three terminal blocks (TB4, TB5, TB6). Fine taps are numbered 1-2-3-4, with "1" providing the **lowest** output, increasing to "4," yielding the **highest** output. A "fine" tap adjustment raises or lowers the current approximately four amperes. The three fine tap terminal blocks are interconnected by means of a three-lead jumper wire assembly attached to like-numbered terminals.
 - To *increase* the DC output, move the jumper wire assembly to tap the next (3) *higher* numbered terminals, for example, move from terminals "2" to terminals "3." ALL TAPS MUST BE ON THE SAME NUMBERED POSITION (1-1-1, 2-2-2, 3-3-3, or 4-4-4). If the DC output is still too low when terminals "4" are interconnected, see the following instructions for adjusting "coarse" taps.
 - To *decrease* the DC output, move the jumper wire assembly to tap the next (3) *lower* numbered terminals, for example, move from terminals "3" to terminals "2." ALL TAPS MUST BE ON THE SAME NUMBERED POSITION (1-1-1, 2-2-2, 3-3-3, or 4-4-4). If the DC output is still too high when terminals "1" are interconnected, see the following instructions for adjusting "coarse" taps.
5. *Coarse adjustment* of the DC current is made to the *LETTERED* taps found on the lower three terminal blocks (TB1, TB2, TB3). Coarse taps are lettered W-X-Y-Z, with "W" providing the **lowest** output, increasing to "Z" at the **highest** output. The coarse tap terminals connect to contactor terminals T1, T2, and T3. The (3) contactor leads must connect to the same lettered step (W-W-W, etc.). A "coarse" tap adjustment raises or lowers the current approximately twelve amperes.
 - To *increase* the coarse DC output, move each of the contactor leads to tap the next *higher* lettered terminals, for example, move from terminals "W" to terminals "X." ALL TAPS MUST BE ON THE SAME LETTERED POSITION (W-W-W, X-X-X, Y-Y-Y, or Z-Z-Z). Place the fine tap jumper on 1-1-1. Ignite the lamp, check the output, and increase the fine tap setting as required.
 - To *decrease* the coarse DC output, move each of the contactor leads to tap the next *lower* lettered terminals, for example, move from terminals "Y" to terminals "X." ALL TAPS MUST BE ON THE SAME LETTERED POSITION (W-W-W, X-X-X, Y-Y-Y, or Z-Z-Z). Place the fine tap jumper on 1-1-1. Ignite the lamp, check the output, and increase the fine tap setting as required.

NOTE: Balance power supply output; set power supplies *at or near* the same output setting, i.e.:

Power Supply "A" X-X-X, 4-4-4 (or as required)

Power Supply "B" Y-Y-Y, 1-1-1 (or as required)

6. Check the voltmeter and read the arc voltage. The voltage should read between 50 and 54 volts DC. If the actual measured voltage is *not* in this range, consult your bulb supplier immediately.
7. Inspect tap connections to verify that the terminal is clamping the copper conductor, not the insulation. Make certain all terminal clamping screws are tight.
8. Whenever making a coarse adjustment, again check the output current and make certain the current is within the desired range. A fine tap re-adjustment is frequently required after changing coarse taps.
9. After prolonged operation, the light output of the xenon bulb will decrease. This is a normal factor of bulb aging, and can be compensated by raising the DC output of the xenon power supplies. If the bulb was first operated at "nominal" current, the power supply output can gradually be increased to, but *not in excess of*, the maximum current specified by the bulb manufacturer (210 A.). Increase the current as instructed above. Decrease the power supply output to its former "nominal" current level (180 A.) upon the installation of a new replacement bulb.

FOCUS AND X-Y ADJUSTMENT INSTRUCTIONS FOR SYSTEMS w/ ELECTRIC FOCUS

NOTE

FAMILIARIZE YOURSELF WITH THE LOCATION AND IDENTIFICATION OF THE COMPONENTS OF THIS SYSTEM AND ALSO THE NORMAL OPERATION OF THE SYSTEM BEFORE ATTEMPTING ANY ADJUSTMENT OR SERVICE.

NOTE

COMPLETELY READ THROUGH AND HAVE A GOOD UNDERSTANDING OF THE PROCEDURES BEFORE ATTEMPTING TO SERVICE THIS SYSTEM. FAILURE TO DO SO MAY RESULT IN FATAL INJURY OR EQUIPMENT DAMAGE.

EQUIPMENT REQUIRED

1. ALLEN WRENCH 5/32"
2. #5 WELDERS GLASSES OR VERY DARK SUNGLASSES

WARNING

THE SEL10 SYSTEMS PROJECT A VERY INTENSE BEAM OF FULL-SPECTRUM LIGHT. THE USE OF DARK GLASSES WHILE ADJUSTING THE BEAM PARAMETERS ON A LIGHT-COLORED REFLECTIVE SURFACE AT A CLOSE DISTANCE IS MANDATORY.

WARNING

NEVER LOOK DIRECTLY INTO A LIGHTED FIXTURE'S LIGHT SOURCE.

ADJUSTMENT INSTRUCTIONS

1. Loosen the positioning fasteners and point the lamphead toward a wall, ceiling, or other flat surface at least 10 feet away.
2. Locate the focus switch located on the control panel on the back of the lamphead housing.
3. Remove the front cowl and locate the X & Y adjustment holes located on the lower small sides of the fixture at the ends of the front spider arms.

WARNING

SEL10 SYSTEMS PROJECT A VERY INTENSE BEAM OF FULL-SPECTRUM LIGHT. CAUTION MUST BE TAKEN WHEN POINTING THE BEAM AT AN OBJECT AT A DISTANCE OF LESS THAN 100 FEET WITH THE FOCUS SET FOR A CONVERGING BEAM. COMBUSTIBLE OBJECTS AND OBJECTS WITH A DARK COLOR MAY UNEXPECTEDLY IGNITE IF CARE IS NOT TAKEN IN THE FOCUSING AND POSITIONING OF THE BEAM.

4. Energize the fixture and ignite the lamp. A new xenon bulb should be drawing 180-185 amperes.
5. Adjust the focus by moving the focus switch up or down to produce a diverging beam pattern with 2 or 3 clearly defined rings of light with or without an off-center "hot" spot.
6. Adjust the X & Y adjustment screws using a 5/32" allen wrench to move the inner rings of light to create concentric rings with the "hot" spot at the center of the light field. Turning the adjustment screw clockwise will move the rings toward that adjustment axis and turning the screw counterclockwise will move the rings away from that adjustment axis.

FOCUS AND X-Y ADJUSTMENT INSTRUCTIONS (continued)

7. Readjust the focus switch to set the desired beam spread.
8. Replace the front cowl; reposition the lamphead and resecure the position locking fasteners.

XENON BULB MAINTENANCE

Allow the blowers to operate for at least (15) minutes after extinguishing the arc. This measure is *required* by the bulb manufacturer to comply with bulb warranty conditions.

In order to insure maximum bulb life, the following procedures should be followed every 75-100 hours of operation.

BULB ROTATION

If the fixture is used in a position other than pointed within 15% of vertical, the bulb should be rotated 1/3 of a turn to insure even deposition of the vaporized tungsten generated by the arc inside the bulb.

ADJUSTMENT PROCEDURES

1. Refer to the instructions for removal and installation of the bulb, noting all warnings.
2. Follow the disassembly procedure for a fixture with the bulb installed steps 1 thru 5.
3. When rotating the bulb for removal, continue LIGHTLY pressing rearward on the bulb. The threads of the bulb will ride out of their current leads and drop into the next set of threads in the receiver block. When this happens, you will feel the bulb drop down into the receiver block.
4. Immediately stop turning the bulb and reverse direction to screw the bulb in at the new orientation.
5. Complete reinstalling the bulb per the bulb installation procedure.

POWER LEVEL ADJUSTMENT

Check the output power level of the system and readjust as necessary. A temporary current increase, not exceeding 210 amperes, may enhance bulb ignition at its new position following rotation. After ten to twelve hours of operation at the increased current, the arc will re-establish, and current may be returned to the previous level.

Output may be increased to maintain light output as the bulb ages, but output must remain below 210 amperes. SEE POWER ADJUSTMENT PROCEDURES preceding.

TRANSPORTING THE SEL 10

It is recommended to remove the xenon bulbs before moving the SEL10. While there is little explosion danger in moving the units with properly cooled bulbs and all lamphead covers in place, the bulb manufacturer may not honor warranty claims on bulbs broken during transport. Under no circumstances should the units be moved until the bulbs have cooled to ambient temperatures.

See the illustration facing Page 1 for the recommended method of securing the SEL10 for transport. Raise the lamphead to the full vertical position and replace the upper clamping knob as shown. Rotate the lamphead to align the yoke with the transport support mechanism and raise the hinged plate. Secure the yoke in position using the (2) headless set screws. Tie-down brackets mounted to the upright members of the yoke provide additional points to secure the lamphead if desired.

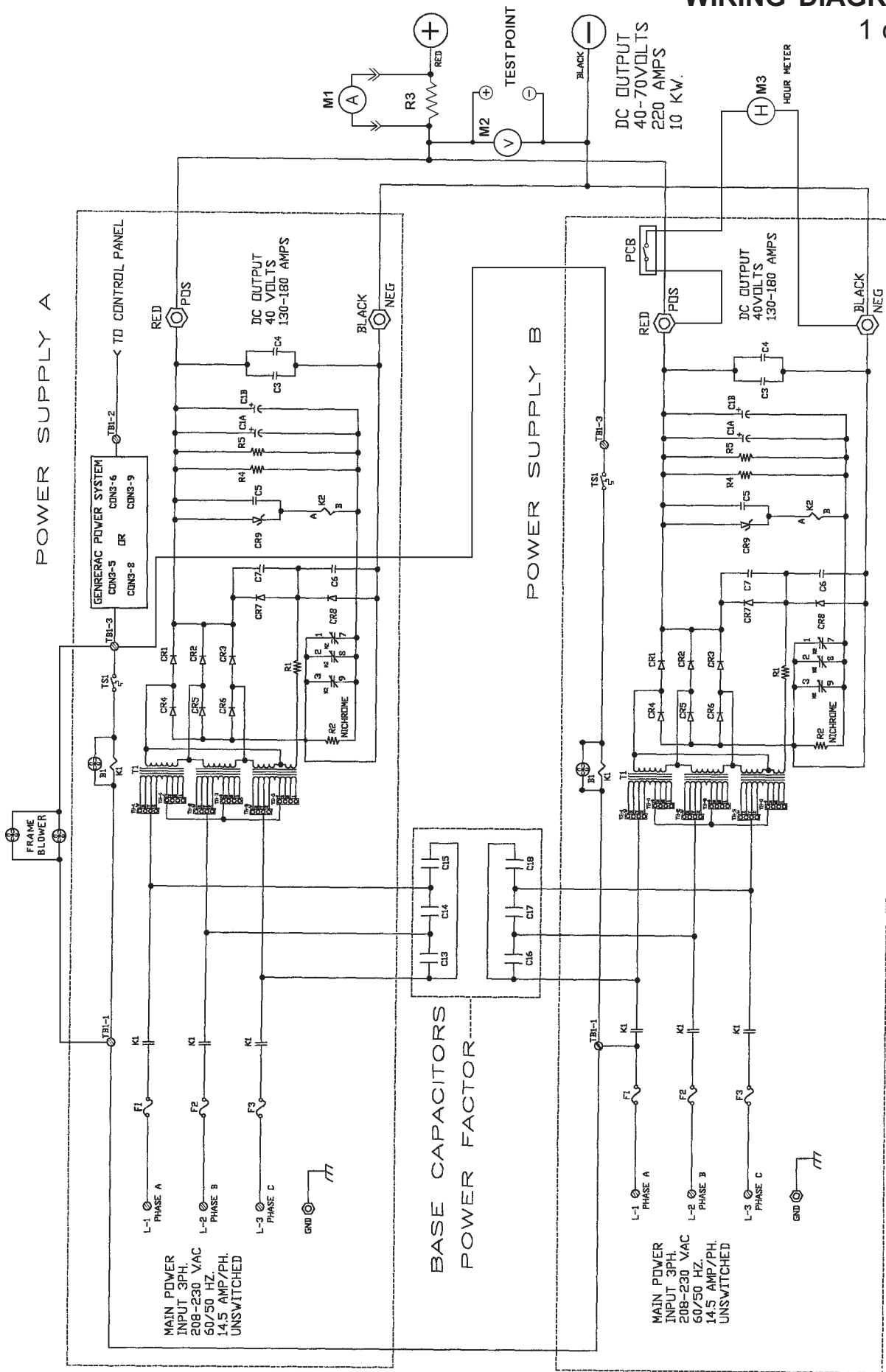

WIRING DIAGRAM

2 of 3

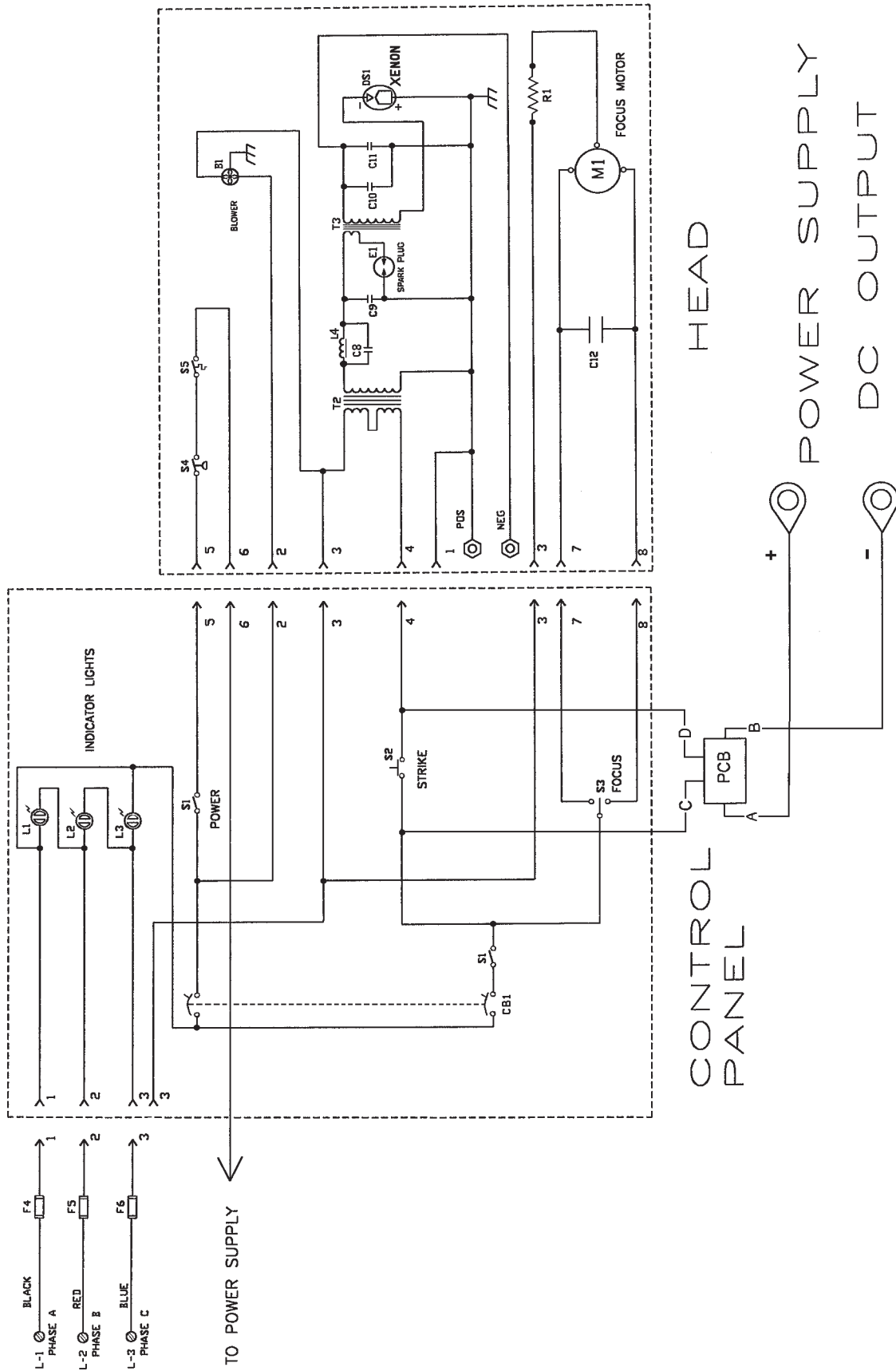

PARTS LIST, CONTROL PANEL and POWER SUPPLIES A & B (Diagram 1 of 2)

Ref.		
<u>Desig.</u>	<u>Part No.</u>	<u>Description</u>
B1	81-33026	Blower
C1A,B	61-08027	Capacitor, 5400 μ f, 200 V.
C3,4	81-08005	Capacitor, .33 μ f
C5	81-08029	Capacitor,.01 μ f, 600 V.
C6,7	81-08025	Capacitor, .005 μ f, 800 V.
C13-18	31-08134	Capacitor, 4 μ f, 370 V.AC
CR1-3	81-47004	Forward Diode, Rectifier; 100 A. 300 V.
CR4-6	81-47001	Reverse Diode, Rectifier; 100 A. 300 V.
CR7,8	81-47006	Boost Diode, 3 A. 600 V.
CR9	81-17002	Zener Diode, 36 V. 5 W. (1N5365B)
F1-3	31-21038	Fuse, 30 A. 250 V.
K1	81-14001	Contactora
K2	81-45016	Relay, 120 V.AC Coil
M1	31-32006	Ammeter, 0-300 A.DC
M2	31-32007	Volt Meter, 0-100 V.DC
-	31-98160	Test Point Socket, Black
-	31-98162	Test Point Socket, Red
M3	31-32004	Elapsed Time Meter*
PCB	32-70140	Printed Circuit Board, Current Detector for M3
R1	81-46026	Resistor, 100 Ohm, 100 W.
R2	92-70026	Nichrome Resistor
R3	81538000	Shunt, 300 A. 50 mV.
R4,5	81-46006	Bleeder Resistor, 2500 Ohm, 10 W.
T1	91-64011	Power Transformer
TS1	81-61010	Thermal Switch, Open at 210° F. (100° C.)

* Elapsed Time Meter may connect to either Power Supply A or B

PARTS LIST, CONTROL PANEL and LAMPHEAD (Diagram 2 of 2)

Ref.		
<u>Desig.</u>	<u>Part No.</u>	<u>Description</u>
B1	32-70228	Squirrelcage Blower, 230 V.AC, 50/60 Hz.
C8	31-08009	Capacitor, .0047 μ f
C9	31-08012	Capacitor, 2400 pf, 20 kV.
C10	79127000	Capacitor, .01 μ f, 500 V.
C11	31-08011	Capacitor, .47 μ f
C12	31-08134	Capacitor, 4 μ f, 370 V.AC
CB1	32-61015	Circuit Breaker
DS1	31-30244	Xenon Bulb, 10 kW Type "XT"
E1	31-61009	Spark Plug (Air Gap)
F4-6	21-21002	Fuse, Type 3AG, 5 A.
L1-3	32-30076	Indicator Light, Amber (3 req'd.)
L4	31-71042	Choke, 16 AWG Magnet Wire
M1	32-70328	Bulb Focus Motor, 115 V.AC, 50/60 Hz. (with R1)
R1	11-46110	Resistor, 100 Ohm, 50 W. (incl. with M1)
PCB	32-00009	Igniter Printed Circuit Board Assembly (see Diagram 3 of 3)
S1	31-61048	Switch
S2	31-61011	Pushbutton Switch
S3	31-61049	Switch
S4	31-61078	Pressure Switch
S5	31-61134	Thermal Switch, Open at 325° F. (163° C.)
T2	31-64004	Transformer, High Voltage
T3	32-50230	Transformer, RF

WIRING DIAGRAM

3 of 3

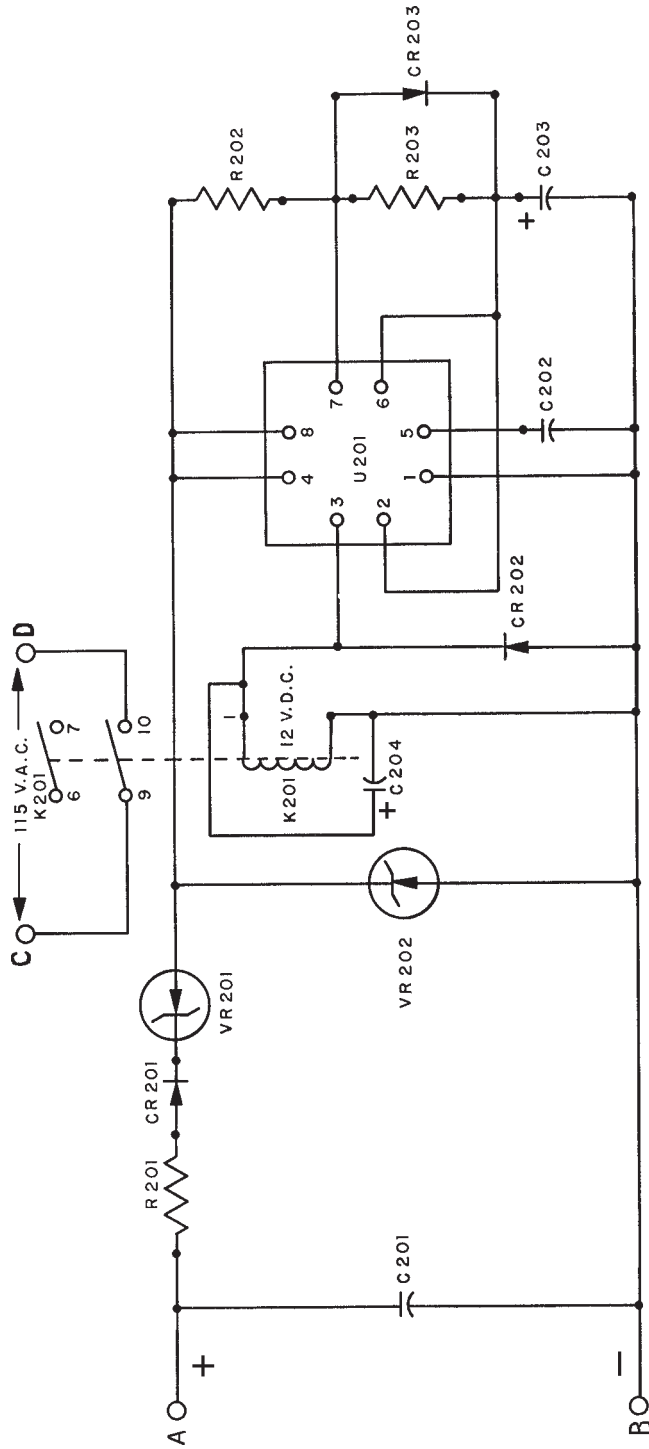

Ref.	Design.	Description	Part No.	Description
C201	R201	Capacitor, .05 µf, 600 WVDC	39157	Resistor, 1k Ohm, 12 Watt
C202	R202	Capacitor, .01 µf, 600 WVDC	39158	Resistor, 100k Ohm, ½ Watt
C203	R203	Capacitor, 15 µf, 30/35 WVDC	39159	Resistor, 200k Ohm, ½ Watt
C204	U201	Capacitor, .1 µf, 600 WVDC	72185	Timer IC, Motorola MC11455P1
CR201	-	Diode, 2.5 A, 1000 PRV	39164	IC Socket, (6) Pin
CR202	VR201	Diode, 2.5 A, 1000 PRV	39211	Zener Diode, 1N5377A
CR203	VR202	Diode, 2.5 A, 1000 PRV	39162	Zener Diode, 1N4742
K201	-	Relay, P&B R10-E1-W2S800	39145	PC Board (less Components)
-	*	Relay Socket	32-00009	PCB Assembly, Complete
-	-	Relay Hold-Down Spring		

Igniter Printed Circuit Board Assembly

POWER SUPPLY MAINTENANCE

VERY LITTLE MAINTENANCE is required to keep this power supply in good operating condition. Like most lighting equipment, cleaning is the most important element.

WARNING

Turn off ALL primary AC power before making any adjustments or performing service procedures. Allow several minutes for the capacitors to drain stored energy. Allow the power supply to cool to ambient temperature.

1. Remove all accumulated dust and dirt from the rectifier. Vacuum the heat sinks. Make certain all air inlets and outlets are unobstructed.
2. Check all electrical connections for tightness. Clean, retighten, or replace any discolored connections or terminals.
3. Apply a drop or two of SAE 20-weight oil to the squirrelcage blower motor bearings. It is necessary to dismount the blowers from the chassis plate to access the oil holes.

POWER SUPPLY TROUBLESHOOTING

WARNING: Exercise extreme caution when taking voltage measurements in a power "ON" condition. Allow the capacitors (2) minutes to discharge.

POWER LINE PROBLEMS

PRIMARY POWER (AC source) problems are most commonly (a) complete loss of AC power, or (b) phase loss, in which one phase loses power.

- a) Check line safety switch ("ON"). Check fuses or breakers in supply line. Using an AC voltmeter, measure input power at contactor terminals L1, L2, L3.
- b) When power is lost on one phase, the current ripple will increase and trip the AC line circuit breaker (where supplied). To detect a lost phase, measure the AC voltage phase-to-phase at contactor input terminals L1, L2, and L3.

PROBLEMS of this nature, once detected, are generally corrected at the power connection, or in the generator unit.

BOOST CIRCUIT PROBLEMS

The boost circuit generates the high open circuit ("no load") DC voltage which, in conjunction with the igniter pulse, will ignite the xenon bulb. The open circuit voltage should measure at least 110 V.DC.

A tertiary winding on the main transformer (T1) supplies the source for the Boost Circuit. Three wires derive from the T1 transformer; two are single conductors, and the third is a soldered pair. The Boost Circuit should be connected only to the (2) single conductors. Filter capacitors C1A & C1B store energy and also contribute to bulb ignition.

CONTROL CIRCUITRY

The main power transformer is energized by contactor K1, which is pulled by manual actuation of the lamphouse "ON" switch. All lamphouse interlock switches (air pressure & thermal overload) must also be closed to complete the contactor circuit.

CONTROL CIRCUITRY (continued)

Any interruption of the control circuit will disable K1 and open the AC circuit to the rectifier. In addition to the above lamphead interlock switches, thermal switch TS1, mounted to the rectifier heat sink, will open and disable K1 if the temperature at the heat sinks exceeds 190° F. (88° C.). The TS1 switch will automatically reset when temperatures fall to safe levels.

POWER CONVERSION PROBLEMS

Rectification (AC to DC) is performed by bridge diodes CR1 - CR6. CR1, CR2, and CR3 are forward diodes, and CR4, CR5, and CR6 are reverse diodes. The two types are *not* interchangeable.

An open diode will cause a pronounced flicker in the light output. Two or more open diodes will disable bulb ignition. A shorted diode will trip the circuit breaker protecting the AC input line. See the following DIODE TESTING & REPLACEMENT section.

Banked can capacitors C1A & C1B filter the rectified DC output. C1A and C1B capacitors also store energy to contribute to the open circuit ignition discharge. A shorted capacitor can trip the AC circuit breaker.

Relay K2, in the presence of high DC open circuit voltage, will pull and place Resistor R2 in series with Capacitors C1 and C2. This resistor limits the inrush surge and prolongs the discharge of C1A & C1B to promote bulb ignition. If K2 relay fails, ignition may become erratic, and R2 may remain in circuit. With R2 in circuit, ripple will increase to a level noticeable in light output, but not necessarily enough to trip the AC line circuit breaker.

DIODE TESTING & REPLACEMENT

1. Disconnect the diode from its circuit. Inspect for discoloration, oxidation, or loose crimp at lead junction.
2. A "shorted" diode will show low resistance in both directions. An "open" diode will have infinite resistance in both directions. An Ohmmeter test is required.
3. a) Analog VOM: Select R x 1 Ohm scale. With meter leads connected in one direction, the reading should be zero (or nearly so); reversing the meter leads should show very high resistance. If the diode does not exhibit these characteristics, replace it. NOTE DIODE TYPE: forward or reverse.
b) Digital VOM: Select "Diode Test." With meter leads connected in one direction, the reading should be "OL" (overload); reversing the meter leads should display approximately .4 volt. If the diode does not exhibit these characteristics, replace it. NOTE DIODE TYPE: forward or reverse.
4. Carefully clean the area of the heat sink in which the diode mounts. Apply heat sink compound (Radio Shack #276-1373 or equivalent) using a wood or plastic spatula or stick. A thin layer is adequate.

WARNING

HEAT SINK COMPOUND IS HIGHLY CAUSTIC.
Do not apply with fingers; keep away from eyes. Carefully follow ALL the instructions printed on the package.

5. Install the new diode and tighten securely for maximum mechanical contact and electrical conduction. Clean and firmly secure the lead terminal to the buss.

POWER SUPPLY TROUBLESHOOTING

Contactor does not energize (no audible “click”).

1. Line safety switch open. Turn “ON.”
2. Circuit breaker or fuse in AC line open. Check AC source.
3. Faulty contactor coil or loose connection at coil terminals. Repair or replace.

Contactor pulls but lamphead igniter does not fire.

1. Faulty contactor contacts. With coil energized, check for continuity across the contacts from the “L” side to the “T” side; repair or replace if defective.
2. Insufficient DC output. See INSTALLATION section; increase taps as required.
3. Faulty igniter.
4. Low open circuit voltage (less than 110 V.DC).
 - a) Check ceramic resistor R1; should be in circuit and measure 100 Ohms.
 - b) Check boost diodes CR7 and CR8. See preceding DIODE TESTING section.
 - c) Check filter capacitors C1A and C1B. Replace if defective.
5. Defective igniter printed circuit board assembly. Press STRIKE switch to override; do not hold STRIKE switch longer than *one second* to prevent damage to high voltage transformer.

Bulb requires multiple ignition pulses to light.

1. Insufficient DC output. See INSTALLATION section; set taps as required.
2. Faulty K2 relay. Replace if defective.
3. Faulty or expired xenon bulb. Check for darkened envelope, worn electrodes; replace if required.
4. One or more faulty bridge diodes. See preceding DIODE TESTING section.

Bulb goes out during operation.

1. Excessive heat at rectifier heat sinks; thermal switch TS1 opening. Check for free air flow, blower(s) operating at full speed. Check for loose connection.
2. Open lamphead thermal interlock switch.
3. Defective bulb. Check for scorched electrodes or discolored envelope.

Excessive flicker in light output.

1. Improper tap setting. All taps must be on same numbered or lettered step.
2. Faulty bridge diode. See preceding DIODE TESTING section.
3. Faulty xenon bulb. Check for cracked or sagging electrode(s).
4. Open filter capacitor C1A or C1B. Replace if defective.

Bridge diodes (CR1-6) fail repeatedly.

1. Insufficient air flow; defective blower. Clean, repair, or replace as required.
2. Incorrect replacement diode. Use only the specified rated diode(s).

LAMPHEAD MAINTENANCE

The SEL10 lamphead requires very little maintenance to keep it in good working order. Cleanliness is the most important element.

The reflector should be cleaned periodically with a soft, clean, lint free cloth to remove any dust from the reflecting surface. If excessively soiled, use of a mild commercial glass cleaner (Windex® or equivalent) is acceptable; USE NO ABRASIVE CLEANERS.

The xenon bulb should be checked occasionally for the presence of foreign material on the envelope. Any dirt or other foreign material should be removed promptly. Use only alcohol and a clean cloth to clean the bulb; rinse with distilled water and dry carefully. DO NOT touch the bulb with bare fingers, and observe all safety procedures when working around the bulb.

The inside of the lamphead and the impeller blades of the blower should be cleaned periodically, depending on the dust conditions at each installation. Although the blower motor may have oil ports, the bearings are factory sealed and require no lubrication.

Check all electrical connections periodically for tightness, especially the DC leads at the xenon bulb and igniter.

Follow the instructions on Page 10 regarding periodic bulb rotation. After rotating a bulb, increase current to the maximum allowable level, and operate the bulb at this level for 10 to 12 hours. This period will re-excite the thorium in the cathode tip and allow the new arc pattern to establish. After the 10 or 12 hours, return the current setting to its previous level.

Always allow the lamphead blower to operate for at least ten minutes after extinguishing the bulb. Failure to do so will shorten bulb life.

LAMPHEAD TROUBLE CHART

ALLOW THE LAMPHEAD to cool, with all blowers operating, for at least (20) minutes before opening.

Normal Operation:

The lamphead blower will start when the generator first supplies power to the SEL10. When the control panel SYSTEM switch S1 is in the "ON" position, the power supply blowers will start, and the AC circuit to the xenon power supply will energize the circuitry necessary to supply DC voltage to the igniter and bulb.

The DC open circuit ("no load") voltage will be detected by the igniter printed circuit board, which in turn will close the circuit to the igniter. There will be an audible high voltage arc ping at the spark gap in the igniter and at the xenon bulb. The bulb should ignite immediately after one or two of these high voltage pulses, and the lamp current will adjust to the sustaining level set at the xenon power supply. The STRIKE switch may be pressed to override a defective igniter PC board.

A reed switch mounted to a printed circuit board tie-wrapped to a DC output cable in the xenon power supply will detect current flow and complete a circuit to the elapsed time meter. The elapsed time meter will record the unit's hours of operation.

Troubleshooting:

If the xenon bulb does not ignite, observe the following operational sequences for assistance in locating and isolating the trouble area.

When the three phase indicator lights are "ON," the AC circuit in the power supply is trouble free up to the terminal block (L1, L2, L3) in the power supply. Check the 230 V.AC control circuit at the blower leads at terminals #2 and #3.

TROUBLESHOOTING (continued)

With the squirrelcage blower operating, the air plenum should compress, completing the circuit to the igniter. The elapsed time meter should start to indicate elapsed time. If this meter does not operate, check for continuity at the SYSTEM switch. Check continuity of the air pressure switch; should read 0 Ohms between "NO" and "COM" when actuated. A defective elapsed time meter will not prevent bulb ignition.

With the SYSTEM switch in the "ON" position, a distinct high voltage arc ping at the igniter spark gap should be heard, and a flash from the xenon bulb should be visible, as DC voltage is applied to the bulb electrodes. If the high voltage ping or the flash at the ammeter is not apparent, check for 110 V.DC "No Load" voltage between the lamphouse and power supply. An adequate level of "no load" voltage will close the relay on the igniter PC board and fire the igniter. Momentarily pressing the STRIKE switch will bypass the igniter PC board.

If the correct voltage for the power supply is not measured, the problem is in the lamphouse/ power supply interconnecting cable(s), or in the power supply. See the preceding troubleshooting guide for additional instructions and tests.

If the high voltage arc is audible at the lamphouse, and the bulb does not flash, replace the bulb and attempt ignition with the new bulb.

Using the new bulb, if the high voltage arc is audible at the lamphouse, the flash of the bulb is visible, and ignition is not sustained, the problem is in the power supply.

If the high voltage arc is not audible or the flash of the bulb visible, the trouble is in the igniter or the igniter printed circuit board assembly.

Bulb fails to ignite.

1. AC power not on to lamphouse. If 230 V.AC not read at 3 & 4, check power supply.
2. Air pressure switch S4 not closing. Check for unobstructed hose; clean if required. Check continuity between "NO" and "COM"; replace if defective.
3. Faulty S1 "SYSTEM" switch. Check for voltage at 5 & 6; check for loose wiring. Replace if defective.

Bulb fails to ignite; ping audible, bulb flash visible.

1. Inadequate DC output from xenon power supply. Set power supply output to correct range required for bulb wattage (165-210 A.).
2. Faulty or expired xenon bulb. Replace as required.

Bulb fails to ignite; ping audible, no bulb flash.

1. Faulty xenon bulb. Check for cracked electrodes or darkened envelope. Replace if defective.
2. Ignition pulse shorting to ground. Inspect DC leads for burned insulation; dress leads away from grounded metal components.

No high voltage ping audible; LAMP switch in "ON."

1. Loss of AC control voltage. Check xenon power supply for open thermal switch.
2. Little or no DC "No Load" voltage. Measure DC "No Load" voltage at rectifier output terminals.
3. Defective igniter PC board. Press STRIKE switch to bypass; do not hold switch for longer than *one second*. Repair or replace PC board.
4. Defective "STRIKE" switch. Check for continuity across terminals.
5. Faulty igniter. Check for 230 V.AC at 3 & 4; adequate DC "No Load" measured. Replace igniter if defective.

TROUBLESHOOTING (continued)

Bulb goes out during operation.

1. Xenon power supply overheated; thermal switch open. Check power supply blower(s), air inlets and outlets unobstructed.
2. Lamphouse blower B1 obstructed or overheated. Blower motor is thermally protected and will shut off if overheated; blower will re-start when temperatures fall to safe levels. Clean dust and dirt from blower squirrelcage.
3. Lamphouse blower B1 failed. Check for 230 V.AC at 2 & 3; replace blower if defective.
4. Lamphouse air pressure switch S4 faulty. Check for correct actuation; replace as required.
5. Defective bulb. Check for scorched electrodes or discolored envelope.

Excessive light flicker.

1. Faulty or aged bulb. Check for cracked or sagging electrodes; replace if defective.
2. Defective rectifier diode(s). Dismount and test diodes (see Page 16); replace defective unit(s).
3. Excessive ripple in DC output. See power supply troubleshooting.

Reduced light output.

1. Normal bulb aging. Increase output current. DO NOT EXCEED MAXIMUM CURRENT SPECIFIED BY BULB MANUFACTURER.
2. Soiled reflector. Clean using commercial glass cleaner. USE NO ABRASIVES.
3. Soiled cowl glass. Clean as required.
4. Leaking bulb. Check for high current and low voltage; white or bluish discoloration of envelope. Replace as required.

Extremely long duration between ignition pulses.

1. Low DC "No Load" from xenon power supply. Check "No Load" voltage; see power supply manual.
2. Defective spark gap E1. A "Ping" sound is normal; excessive "Hissing" is abnormal. Replace if defective.
3. Low AC voltage to lamphouse. Check for 230 V.AC at 3 & 4; if below 190 volts, check generator.
4. Defective timer chip on igniter PC board. Replace as required.

Elapsed Time Meter (M3) Fails to Record Hours.

1. Current Detector PCB not in contact with DC lead. PCB must be tie-wrapped to the insulation of one of the heavy DC output leads from the xenon power supply.
2. Defective component on current detector PCB. Repair or replace. Secure replacement board to DC lead as instructed in Step 1.
3. Defective hour meter, Replace as required.

FIGURE 1
Lamphead Assembly

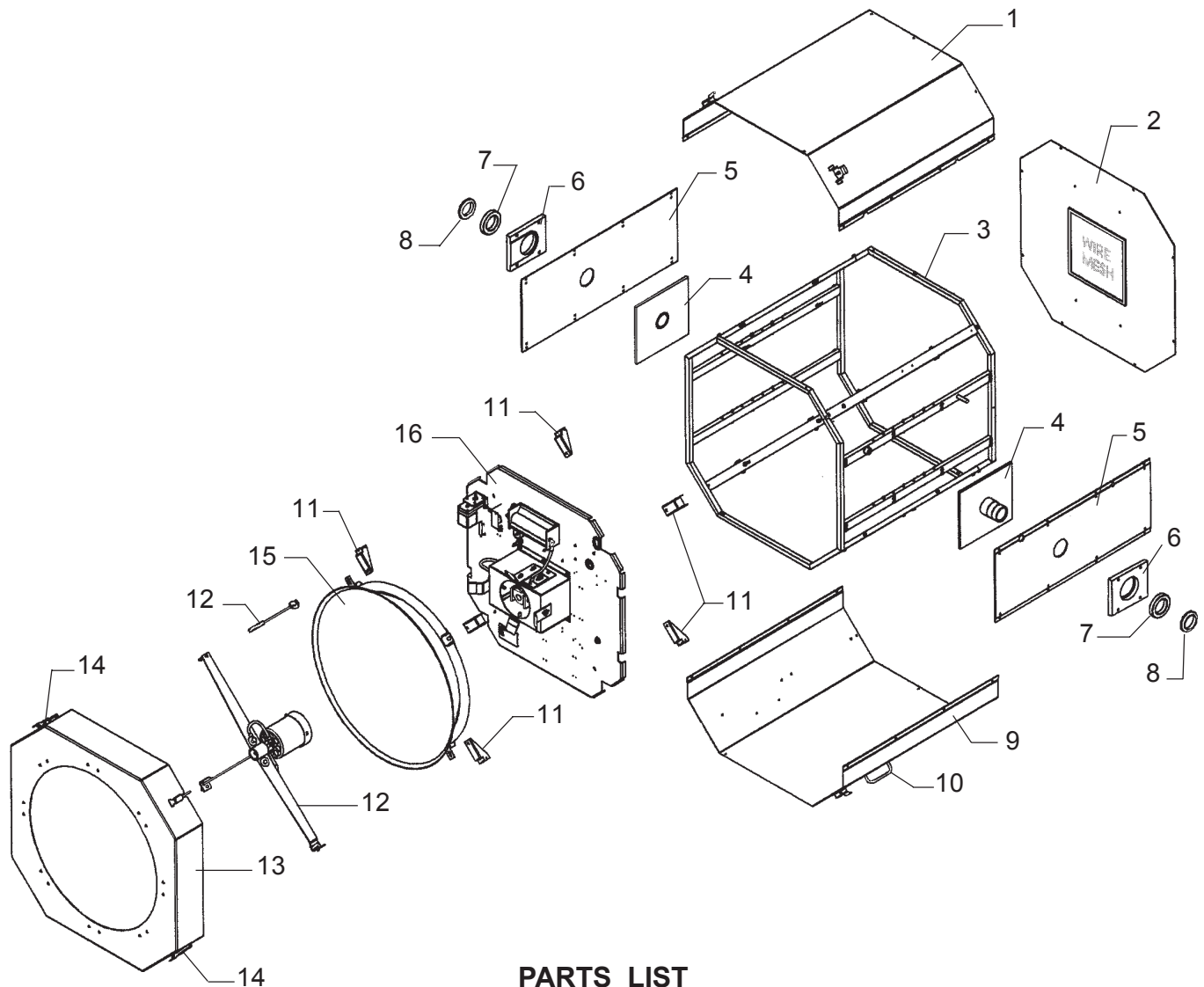

PARTS LIST
Figure 1

Item	Part No.	Description
1	32-00150	Top Cover, Welded Assembly (with Clips)
-	4100503	Mounting Screw, 10-32 x 1/2" Pan Head Philips
2	32-40711	Rear Cover Plate
-	31-98159	Weatherstripping (Order by foot)
-	4100503	Mounting Screw, 10-32 x 1/2" Pan Head Philips
-	32-40667	Air Intake Cover, Welded Assembly
-	4107000	Split Lockwasher, #10
-	4100503	Mounting Screw, 10-32 x 1/2" Pan Head Philips
3	32-40639	Lamphead Frame, Welded Assembly
4	32-40693	Vertical Tilt Axle (2 req'd.)
-	4252001	Mounting Screw, 1/4-20 x 2" Socket Head
-	4257104	Flatwasher, 1/4"
-	4257000	Split Lockwasher, 1/4"
5	32-00122	Side Cover Panel
-	4100503	Mounting Screw, 10-32 x 1/2" Pan Head Philips
6	32-40697	Bearing Housing (2 req'd.)
-	4371250	Mounting Screw, 3/8-16 x 1-1/4" Hex Head
-	4377103	Flatwasher, 3/8"
-	4277001	Split Lockwasher, 3/8"

PARTS LIST, Figure 1 (continued)

<u>Item</u>	<u>Part No.</u>	<u>Description</u>
7	31-04015	Ball Bearing (2 req'd.)
8	31-04037	Nut, Bearing Retaining (2 req'd.)
9	32-00151	Bottom Cover Assembly (with Clips & Handles)
10	32-00098	Handle (2 req'd.)
-	4100503	Mounting Screw, 10-32 x 1/2" Pan Head Philips
11	32-40638	Mounting Bracket (8 req'd.)
-	4100503	Mounting Screw, 10-32 x 1/2" Pan Head Philips
-	4107101	Flatwasher, #10
12	32-50532	Spider & Focus Assembly (see Figure 4)
13	32-00123	Front Cowl Assembly
-	32-40702	Front Cowl, Welded Assembly
-	31-98777	Glass, Front Cowl
-	31-98136	Gasket (not shown)
-	32-20331	Pad, Silicone Rubber (8 req'd.)
-	32-40699	Glass Mounting Bracket (8 req'd.)
-	4080371	Bracket Mounting Screw, 8-32 x 3/8" Flat Head
14	31-18035	Retaining Clamp (4 req'd.)
-	4100371	Mounting Screw, 10-32 x 3/8" Pan Head
15	32-50545	Reflector Assembly, 30" Parabolic
-	4250752	Mounting Screw, 1/4-20 x 3/4" Hex Head
-	4257000	Split Flatwasher, 1/4"
-	4257102	Flatwasher, 1/4"
16	32-50526	Bulkhead Assembly (see Figure 2)
-	4250752	Mounting Screw, 1/4-20 x 3/4" Hex Head
-	4257000	Split Flatwasher, 1/4"
-	4257102	Flatwasher, 1/4"

NOT SHOWN

31-30244 Xenon Bulb, 10 kW Type "XT"

FIGURE 2
Bulkhead Assembly

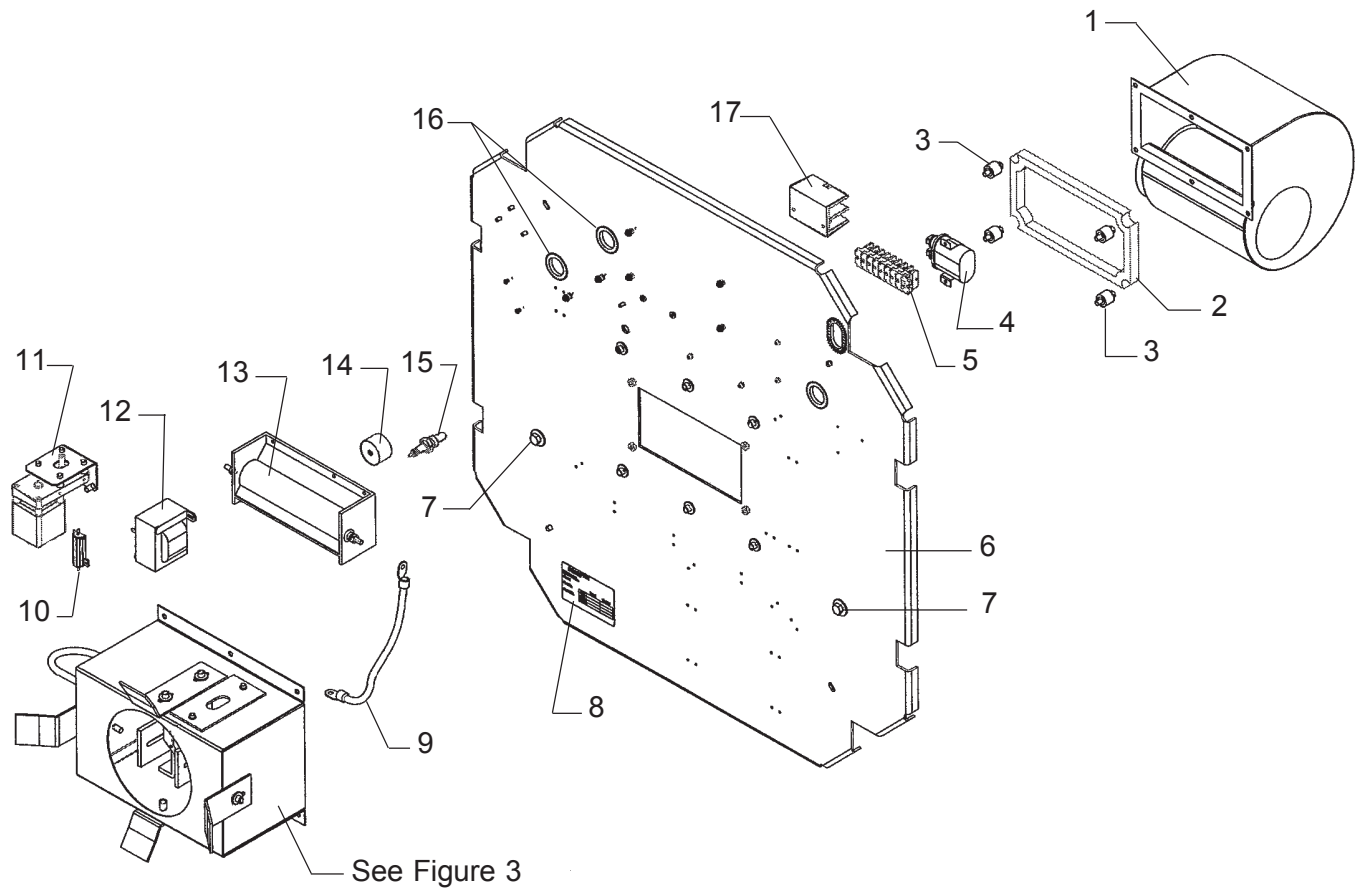

PARTS LIST
Figure 2

Item	Part No.	Description
1	32-70228	Squirrelcage Blower, 220 V.AC, 50/60 Hz.
2	32-00020	Blower Gasket
3	31-98182	Mounting Stud, 10-32 (4 req'd.)
-	4107101	Flatwasher, #10
-	4107000	Split Lockwasher, #10
-	4108001	Hexnut, 10-32
4	31-08134	Capacitor, 4 μ f, 370 V.AC
-	31-10025	Capacitor Clamp
-	4060500	Mounting Screw, 6-32 x 1/2" Pan Head
-	4060700	Split Lockwasher, #6
-	4067101	Flatwasher, #6
5	31-62011	Terminal Block Section (8 req'd.)
-	31-62012	Terminal Block End Plate (2 req'd.)
-	4080624	Mounting Screw, 8-32 x 5/8" Pan Head Philips
-	4087101	Flatwasher, #8
-	4087000	Split Lockwasher, #8
6	32-40643	Bulkhead Plate
-	4251003	Mounting Screw, 1/4-20 x 1" (to Fig. 1 Item 11 Bracket)
-	4257000	Split Lockwasher, 1/4"
-	32-40770	Bulkhead Spacer, 1/4" Aluminum (4 ea. as req'd.)

PARTS LIST, Figure 2 (continued)

<u>Item</u>	<u>Part No.</u>	<u>Description</u>
7	4371004	Contact Screw, Bulkhead; 3/8-16 x 1" Hex Head, Brass
-	4377100	Flatwasher, 3/8" Brass
-	4378003	Hex Nut, 3/8" Brass
-	4377000	Split Lockwasher, 3/8"
-	32-50238	Positive Lead Assembly, Bulkhead to Front Spider (not shown)
8	31-34031	Name & Data Plate, SEL10
9	32-00343	Negative Lead, RF Coil to Bulb Receiver
-	4250502	Contact Screw, 1/4-20 x 1/2" Hex Head Brass
-	4257003	Lockwasher, 1/4" Internal Tooth
-	4257100	Flatwasher, 1/4" Brass
10	11-46001	Fixed Resistor, 100 Ohm, 50 W. (with Item 11)
-	4040500	Mounting Screw, 4-40 x 1/2" Pan Head
-	4047000	Split Lockwasher, #4
11	32-70328	Motor & Bracket Assembly, 115 V.AC, 50/60 Hz. (incl. Item 10)
-	4100500	Mounting Screw, 10-32 x 1/2" Socket Head
-	4107000	Split Lockwasher, #10
12	31-64004	High Voltage Transformer (T2)
-	4080624	Mounting Screw, 8-32 x 5/8" Pan Head
-	4087101	Flatwasher, #8
-	4087000	Split Lockwasher, #8
13	32-50230	RF Coil (T3)
-	4080624	Mounting Screw, 8-32 x 5/8" Pan Head
-	4087101	Flatwasher, #8
-	4087000	Split Lockwasher, #8
14	39110000	Capacitor (C9)
-	4080256	Mounting Screw, 8-32 x 1/4" Pan Head Brass
-	4087103	Flatwasher, #8 Brass
15	31-61009	Spark Plug (E1)
-	4507000	Shakeproof Washer, 1/2"
-	41-35154	Hex Nut, Metric
16	41-98127	Grommet Material, Plastic
17	31-62025	Terminal Block, DC
-	4100503	Mounting Screw, 10-32 x 1/2" Pan Head Philips
-	4107101	Flatwasher, #10

FIGURE 3
Air Plenum Assembly

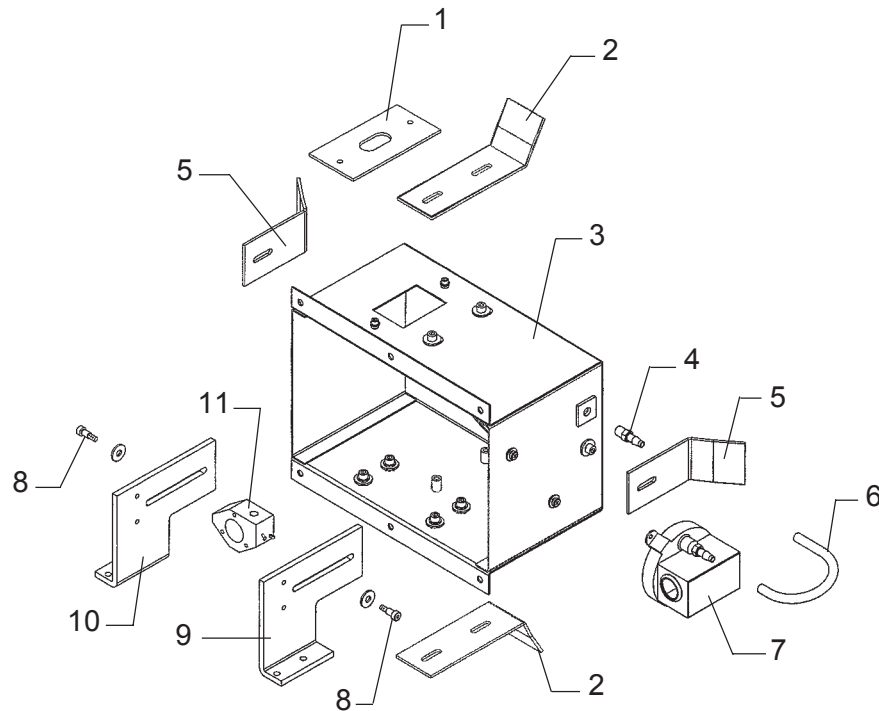

PARTS LIST

Figure 3

<u>Item</u>	<u>Part No.</u>	<u>Description</u>
1	32-40287	Insulator, Negative Lead
-	4080624	Mounting Screw, 8-32 x 5/8" Pan Head
2	32-40666	Bonding Bracket, Large (2 req'd.)
-	4250501	Mounting Screw, 1/4-20 x 1/2" Socket Head
-	4257104	Flatwasher, 1/4"
3	32-40676	Air Plenum, Welded Assembly
-	4250501	Mounting Screw, 1/4-20 x 1/2" Socket Head
-	4257104	Flatwasher, 1/4"
4	31-20001	Hose Fitting (2 req'd.)
5	32-40672	Bonding Bracket, Small (2 req'd.)
-	4250501	Mounting Screw, 1/4-20 x 1/2" Socket Head
-	4257104	Flatwasher, 1/4"
6	32-20324	Hose, Pressure Line
7	31-61078	Pressure Switch (S4)
-	4100503	Mounting Screw, 10-32 x 1/2" Pan Head Phillips
8	41-51755	Shoulder Screw, 10-24 x 3/8" Socket Head, 2 req'd.
-	4257104	Flatwasher, 1/4"
9	31-98770	Insulated Receiver Rail, Right
-	4251002	Mounting Screw, 1/4-20 x 1" Socket Head
-	4257104	Flatwasher, 1/4"
-	4257000	Split Lockwasher, 1/4"
10	31-98769	Insulated Receiver Rail, Left
-	4251002	Mounting Screw, 1/4-20 x 1" Socket Head
-	4257104	Flatwasher, 1/4"
-	4257000	Split Lockwasher, 1/4"
11	32-50050	Rear Bulb Receiver, Threaded
-	32-00343	Negative Lead (see Figure 2, Item 9)

FIGURE 4
Front Spider Assembly

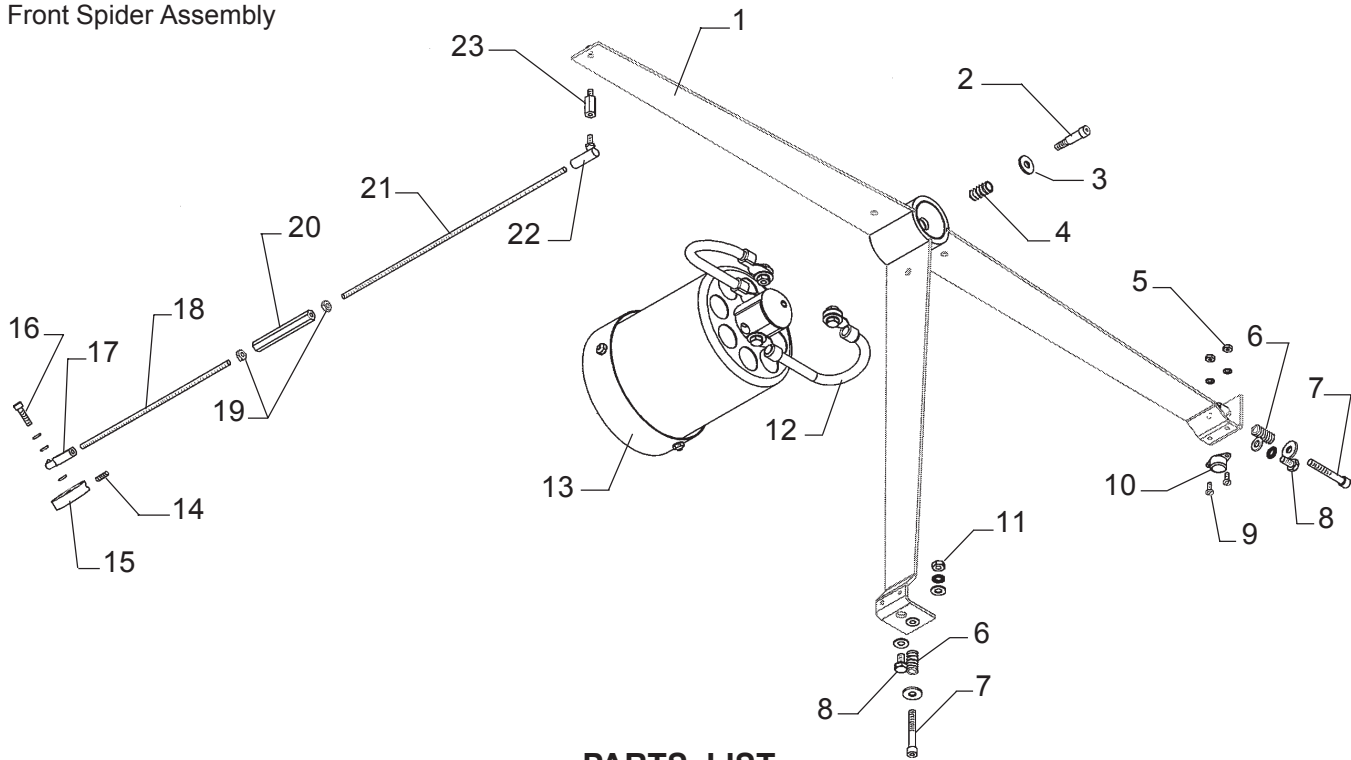

PARTS LIST

Figure 4

<u>Item</u>	<u>Part No.</u>	<u>Description</u>
1	32-40293	Front Spider, Welded Assembly
2	41-51767	Shoulder Screw, 1/4-20 x 3/4"
3	4257102	Spacer, 1/4" Stainless Steel
4	31-58025	Compression Spring
5	4068001	Hexnut, 6-32
-	4067001	Lockwasher, #6
6	31-58024	Compression Spring
7	4251750	Screw, 1/4-20 x 1-3/4" Socket Head
-	4257102	Flatwasher, 1/4"
8	4250502	Contact Screw, Spider; 1/4-20 x 1/2" Hex Head, Brass
-	4257100	Flatwasher, 1/4" Brass
-	4258003	Hex Nut, 1/4-20 Brass (ref. Item 11)
9	4060370	Screw, 6-32 x 3/8" Round Head Phillips
10	81-61010	Thermal Switch (S5)
11	4258003	Hex Nut, 1/4-20 Brass
12	32-50244	Positive Lead, Spider to Bulb Holder (2 req'd.)
-	4250502	Contact Screw, 1/4-20 x 1/2" Hex Head Brass
13	32-00026	Bulb Holder Assembly
-	4100750	Clamping Screw, 10-32 x 3/4" Socket Head (2 req'd.)
14	4080509	Set Screw, 8-32 x 1/2"
15	32-20019	Focus Cam
16	4100500	Screw, 10-32 x 1/2" Socket Head
-	4107000	Split Lockwasher, #10
17	31-98133	Rear Ball Joint
18	31-60089	Threaded Rod, Rear
19	4108001	Locknut, 10-32 Hex
20	31-98753	Turnbuckle, 10-32
21	31-60071	Threaded Rod, Front
22	31-98131	Front Ball Joint
23	41-98096	Standoff, 10-32 x 3/4"
-	4108002	Nut, 10-32 NyLock

FIGURE 5
Yoke Assembly

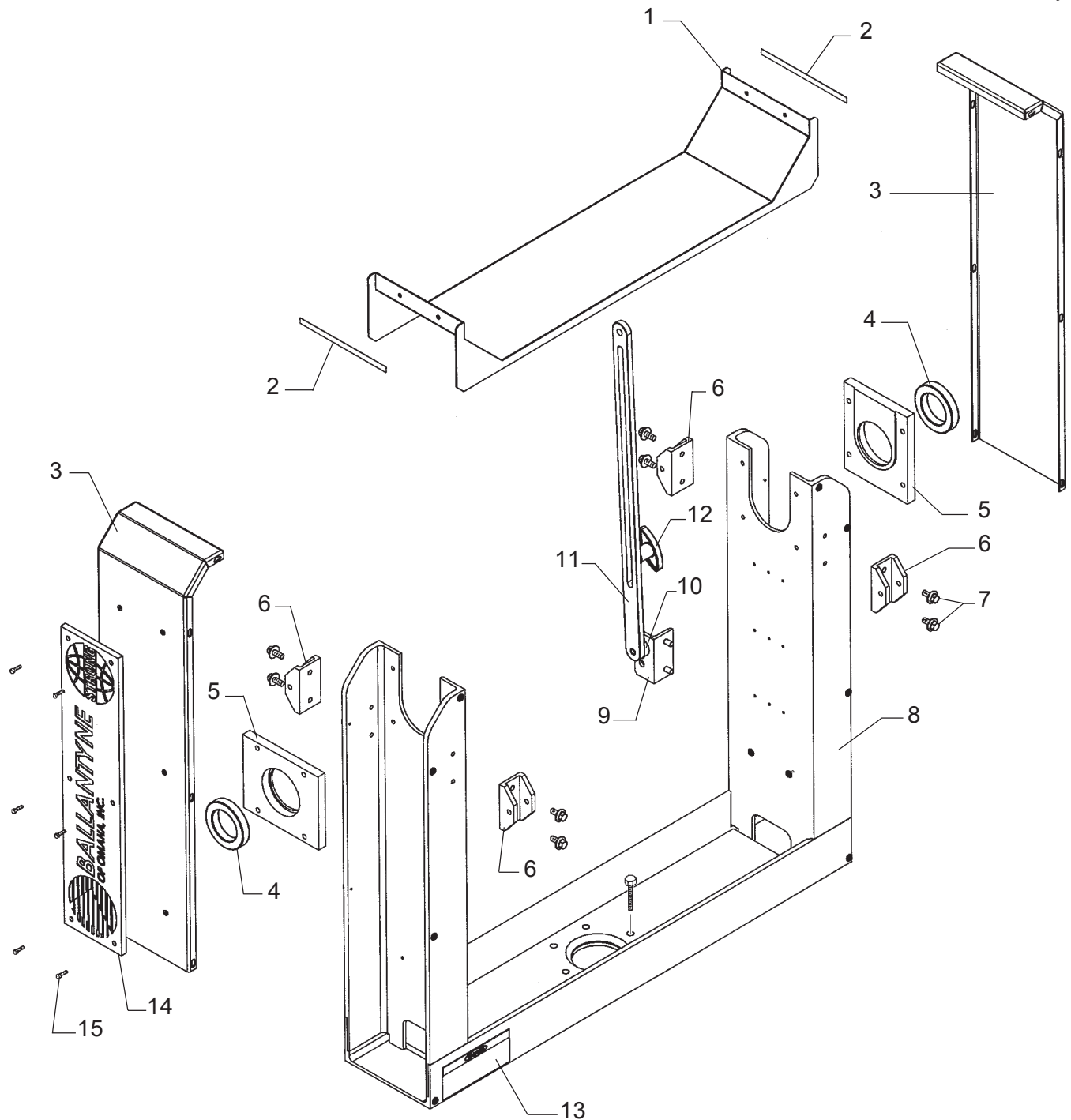

PARTS LIST
Figure 5

<u>Item</u>	<u>Part No.</u>	<u>Description</u>
1	32-40664	Base Cover
-	4100503	Mounting Screw, 10-32 x 1/2" Pan Head Philips
-	4107101	Flatwasher, #10
2	31-60115	Cover Gasket, Weather Seal (2 req'd.)
3	32-40690	Side Cover (2 req'd.)
-	4100503	Mounting Screw, 10-32 x 1/2" Pan Head Philips
-	4107101	Flatwasher, #10
-	4107000	Split Lockwasher, #10

PARTS LIST, Figure 5 (continued)

<u>Item</u>	<u>Part No.</u>	<u>Description</u>
4	31-04015	Ball Bearing (see Figure 1, Item 7)
5	32-40697	Bearing Housing (2 req'd.)
-	4371251	Mounting Screw, 3/8-16 x 1-1/4" Socket Head
-	4377103	Flatwasher, 3/8"
-	4377001	Split Lockwasher, 3/8"
6	32-20302	Tie-Down Bracket (4 req'd.)
7	4371120	Mounting Screw, 3/8-16 x 1" Hex Head
-	4377103	Flatwasher, 3/8"
-	4377001	Lockwasher, 3/8"
8	32-40728	Yoke Frame, Welded Assembly
-	4502001	Mounting Screw (to Fig. 6, Item 2), 1/2-13 x 2" Hex Head
-	4507001	Split Lockwasher, 1/2"
-	4507100	Flatwasher, 1/2"
9	32-20297	Mounting Bracket, Pivot Lock Slide
-	4371120	Mounting Screw, 3/8-16 x 1" Hex Head
-	4377103	Flatwasher, 3/8"
-	4377001	Lockwasher, 3/8"
10	32-20260	Spacer Washer, 1/2" (3 req'd.)
11	32-40716	Slide, Tilt Lock
-	4508001	Hex Nut, 1/2-13
-	4507100	Flatwasher, 1/2"
12	31-28035	Clamping Knob
-	32-20330	Spacer Washer, 1/2"
13	31-34028	DANGER Decal
14	32-20310	Nameplate, BALLANTYNE
15	4100500	Screw, 10-32 x 1/2" Socket Head

FIGURE 6
Base Assembly

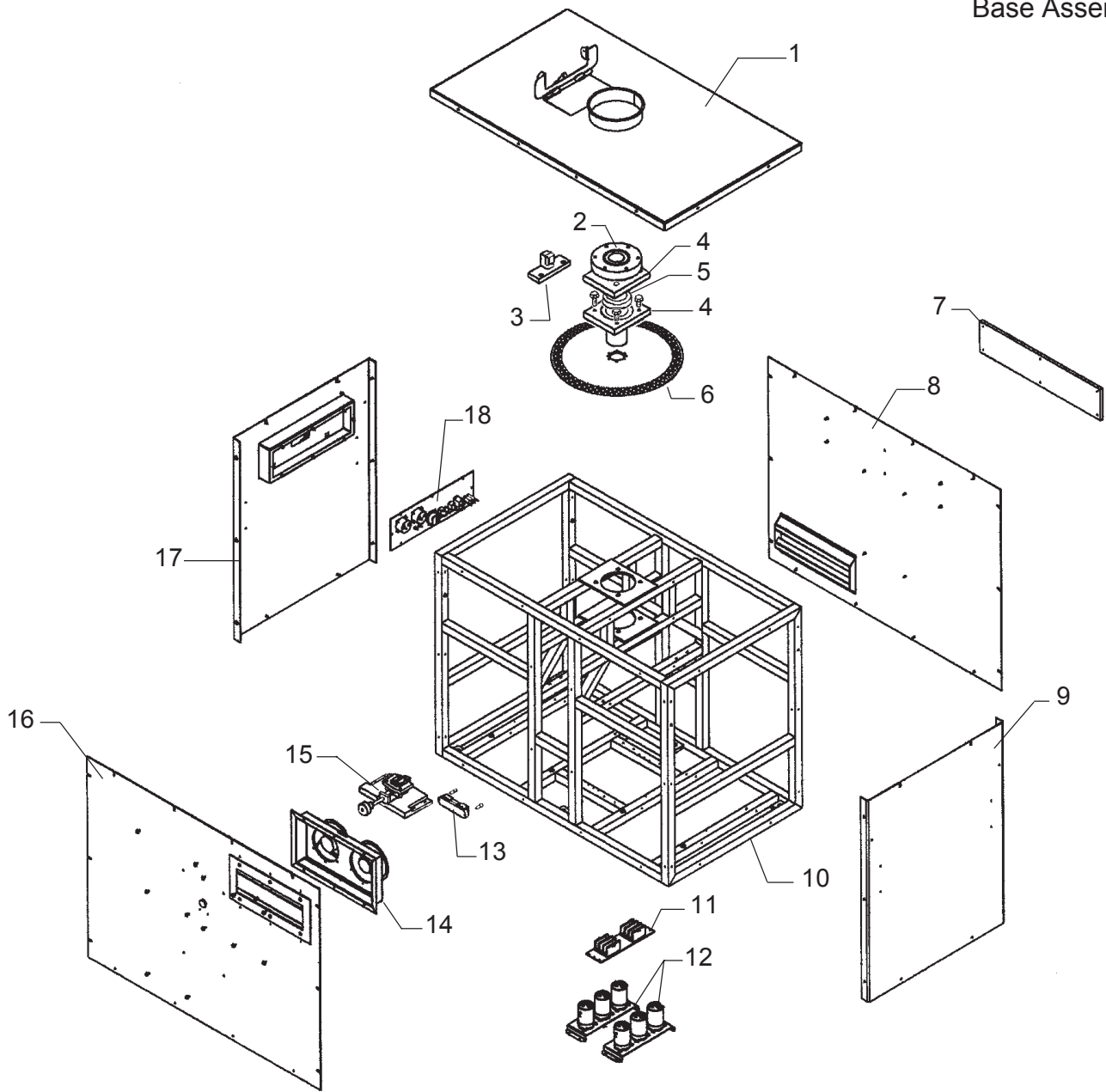

PARTS LIST

Figure 6

<u>Item</u>	<u>Part No.</u>	<u>Description</u>
1	32-40750	Top Cover, Welded Assembly
-	4100503	Mounting Screw, 10-32 x 1/2" Pan Head Philips
-	4107101	Flatwasher, #10
-	31-98174	Plunger Screw, Yoke Retaining (in Transport Support Plate)
2	32-00102	Axle Shaft, Horizontal Pan
3	32-50558	Pan Stop Bracket
-	4502250	Mounting Screw, 1/2-13 x 2-1/4" Hex Head
-	4507001	Split Lockwasher, 1/2"
-	4507100	Flatwasher, 1/2"
4	32-20294	Bearing Block
	31-14016	Ball Bearing
-	4501500	Mounting Screw, 1/2-13 x 1-1/2" Hex Head
-	4507001	Split Lockwasher, 1/2"
-	4507100	Flatwasher, 1/2"

PARTS LIST, Figure 6 (continued)

<u>Item</u>	<u>Part No.</u>	<u>Description</u>
5	32-20308	Collar, Pan Stop
-	4311000	Collar Clamping Screw, 5/16-18 x 1" Socket Head
-	31-37014	Stop Pin, .375 x 1"
-	31-35026	Axle Locking Collar, Threaded (not shown; concealed by lower Item 4 Block)
6	32-00102	Pan Lock Plate
-	4251002	Mounting Screw, 1/4-20 x 1" Socket Head (6 req'd.)
-	4257000	Split Lockwasher, 1/4"
-	4257104	Flatwasher, 1/4"
-	4100620	Mounting Screw, 10-32 x 5/8" Socket Head (2 req'd.)
-	4107000	Split Lockwasher, #10
7	32-20310	Nameplate, BALLANTYNE
-	4101000	Mounting Screw, 10-32 x 1" Socket Head
8	32-40722	Back Cover Panel, Welded Assembly
-	4100503	Mounting Screw, 10-32 x 1/2" Pan Head Philips
-	4107101	Flatwasher, #10
-	4107000	Split Lockwasher, #10
9	32-40715	End Cover Panel
-	4100503	Mounting Screw, 10-32 x 1/2" Pan Head Philips
-	4107101	Flatwasher, #10
-	4107000	Split Lockwasher, #10
10	32-40742	Base Frame, Welded Assembly
11	31-62044	Terminal Block, AC Input
-	4100503	Mounting Screw, 10-32 x 1/2" Pan Head
12	31-08134	Capacitor, Power Factor (C13-C18)
-	31-10025	Capacitor Clamp (6 req'd.)
-	4080370	Clamp Mounting Screw, 8-32 x 3/8" Pan Head
-	32-40724	Capacitor Mounting Plate (2 req'd.)
-	4100503	Plate Mounting Screw, 10-32 x 1/2" Pan Head Philips
-	4107101	Flatwasher, #10
-	4107000	Split Lockwasher, #10
13	81538000	Shunt (R3), 300 A. 50 mV.
-	4080754	Mounting Screw, 8-32 x 3/4" Pan Head
14	32-40710	Blower Panel, Welded Assembly
-	4100503	Mounting Screw, 10-32 x 1/2" Pan Head Philips
-	4107101	Flatwasher, #10
-	4107000	Split Lockwasher, #10
-	71627000	Blower, 220 V.AC, 50/60 Hz. (2 req'd.)
15	32-50544	Pan Locking Pin Mechanism
-	4252250	Mounting Screw, 1/4-20 x 2-1/4" Hex Head
-	4257000	Split Lockwasher, 1/4"
-	4257102	Flatwasher, 1/4"
16	32-40721	Front Cover Panel, Welded Assembly
-	4100503	Mounting Screw, 10-32 x 1/2" Pan Head Philips
-	4107101	Flatwasher, #10
-	4107000	Split Lockwasher, #10
17	32-40712	Control End Panel, Welded Assembly
-	4100503	Mounting Screw, 10-32 x 1/2" Pan Head Philips
-	4107101	Flatwasher, #10
-	4107000	Split Lockwasher, #10
18	32-00011	Control Panel Assembly (see facing page)
-	4100503	Mounting Screw, 10-32 x 1/2" Pan Head Philips
-	4107101	Flatwasher, #10
-	4107000	Split Lockwasher, #10

PARTS LIST, Figure 6 (continued)

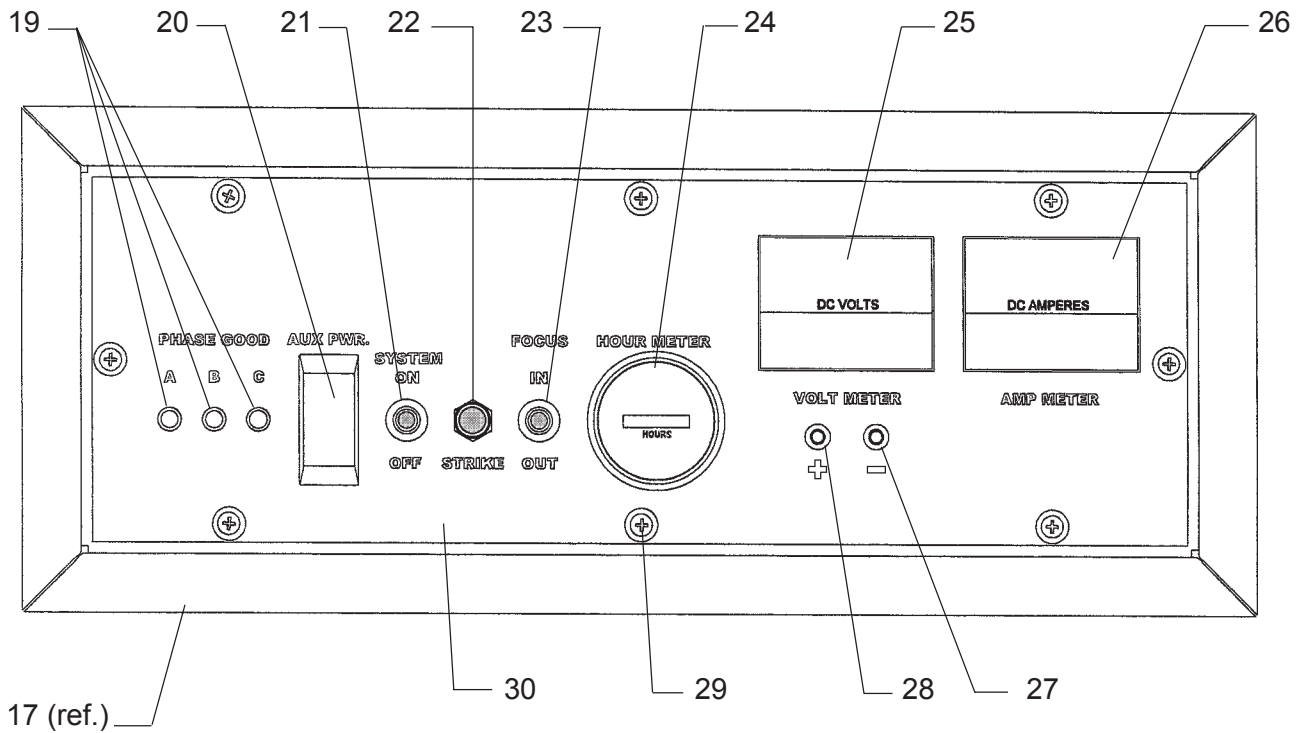

<u>Item</u>	<u>Part No.</u>	<u>Description</u>
19	32-30076	Indicator Light, Amber (L1-L3)
20	32-61015	Switching Circuit Breaker (CB1)
-	32-61126	Switch Boot
21	31-61048	Toggle Switch (S1)
-	11-98150	Switch Boot
22	31-61011	Pushbutton Switch (S2)
-	31-61065	Switch Boot
23	31-61049	Toggle Switch (S3)
-	11-98150	Switch Boot
24	31-32004	Hour Meter (M3)
25	31-32007	Volt Meter (M2)
26	31-32006	Ammeter (M1)
27	31-98160	Test Point Socket, Black
28	31-98162	Test Point Socket, Red
29	4100503	Mounting Screw, 10-32 x 1/2" Pan Head Philips
-	4107101	Flatwasher, #10
-	4107000	Split Lockwasher, #10
30	32-40681	Control Panel Plate (less Components)

NOT SHOWN

J1	31-13033	Molex Plug, (6) Pin Male
J2	31-13288	Molex Receptacle, (6) Pin Female
J3	31-13033	Molex Plug, (6) Pin Male
J4	31-13283	Molex Plug, (2) Pin Male
J5	31-13282	Molex Receptacle, (2) Pin Female
-	71261000	Wire Connector, (1) Pin Female
-	71262000	Wire Connector, (1) Pin Male

FIGURE 7
Xenon Power Supply

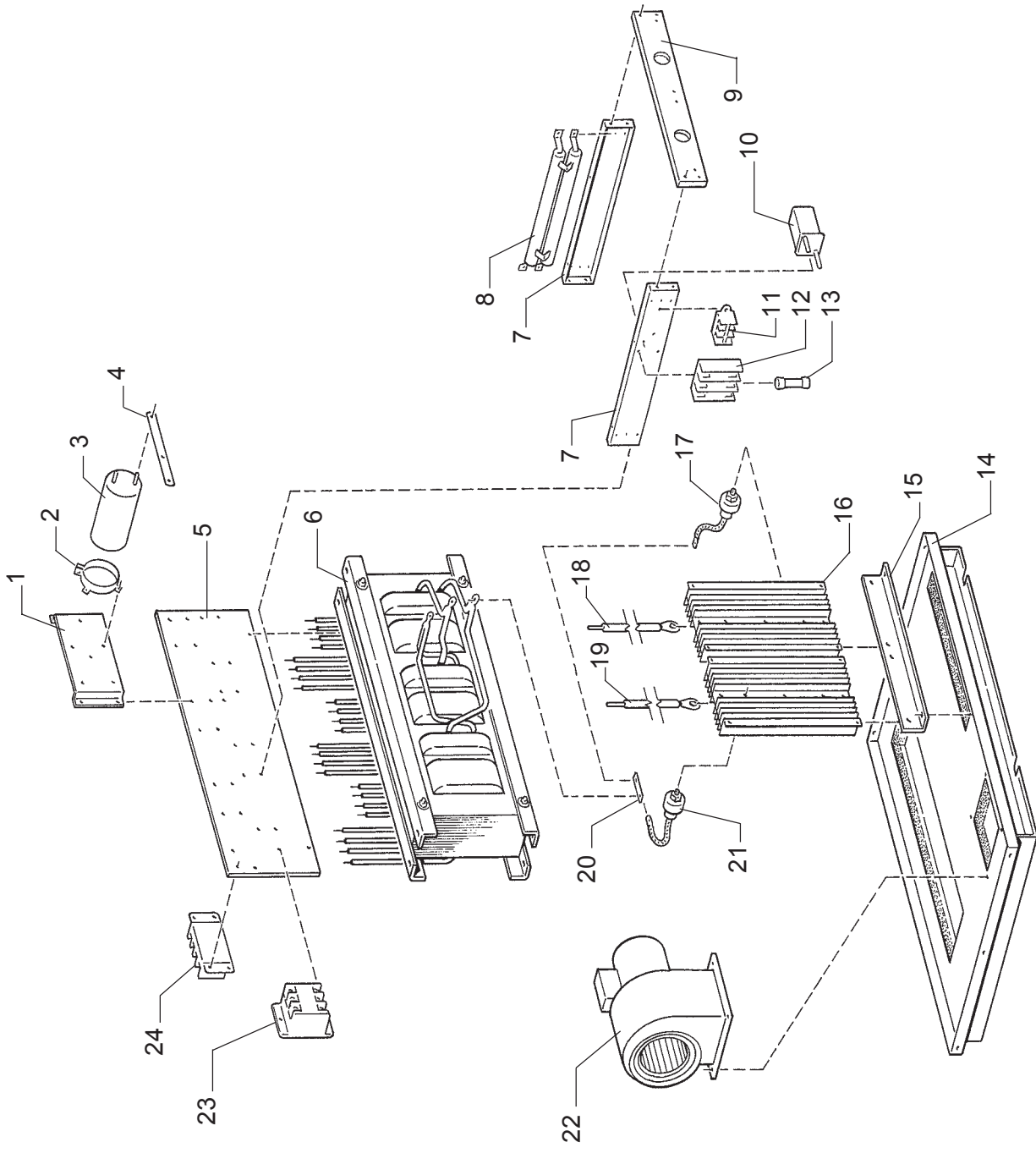

Assembly No. 32-90014

PARTS LIST

Figure 7

<u>Item</u>	<u>Part No.</u>	<u>Description</u>
1	82-40264	Capacitor Mounting Bracket
2	61-06001	Capacitor Clamp (2 req'd.)
3	61-08027	Filter Capacitor, 5400 μ f, 200 V.DC (C1A, C1B)
4	82-40248	Shorting Bar
5	82-40047	Terminal Board Mounting Plate, Phenolic
6	91-64011	Power Transformer, 5000 Watt; 208/230 V.AC Input (T1)
<i>Item 6 Transformer</i>		<i>includes Item 5 Mounting Plate & (6) Item 24 Terminal Blocks.</i>
7	82-40040	Support Bracket, Rectifier Heat Sinks
8	81-46026	Ceramic Resistor (R1,2), 100 Ohm, 100 W.
9	82-40254	Heat Sink Mounting Plate, Phenolic
10	81-45016	Relay (K2)
11	21-62067	Terminal Block Segment (3 req'd.)
-	21-62066	Terminal Block End
12	31-21054	Fuse Block
13	31-21038	Fuse, 30 A. 250 V. (F1, F2, F3)
14	32-40624	Chassis Plate, Welded Assembly
15	82-40255	Heat Sink Mounting Plate
16	82-20032	Heat Sink
17	81-47004	Forward Diode (CR1,2,3), 100 A. 300 V. (1N3290)
18*	61-71010	Positive Lead (Red)
19*	61-71009	Negative Lead (Black)
-	94129000	Ring Terminal (2 per lead req'd.)
20	91-98031	Buss Bar (3 req'd.)
21	81-47001	Reverse Diode (CR4,5,6), 100 A. 300 V. (1N3290R)
-	32-70326	Bridge Rectifier Assembly (Items 16, 17, 20, 21 Assembled)
22	81-33026	Squirrelcage Blower, 230 V.AC, 50/60 Hz. (B1)
23	81-14003	Contactactor (K1)
24	81-62001	Tap Terminal Block (6 req'd.)

NOT SHOWN

32-00009 Igniter Printed Circuit Board Assembly

* Order by *foot*

Strong Entertainment Lighting

EQUIPMENT WARRANTY

Strong Entertainment Lighting agrees that its products shall be free from defects in materials and workmanship for a period of one (1) year, from the date of original shipment from its factory. This warranty is nontransferable and applies to the original purchaser only. Said warranty will not apply if equipment is used in conditions of service for which it is not specifically intended. The manufacturer is not responsible for damage to its apparatus through improper installation, physical damage or poor operating practice.

If any device is found to be defective under the warranty, the buyer should notify the manufacturer. Such equipment will be repaired or replaced, at manufacturer's option, free of all charge except transportation, F.O.B. its factory. Any such repair or replacement by the manufacturer shall constitute fulfillment of all obligations to the purchaser. This warranty does not include troubleshooting expense, labor charges associated with service calls, and disassembly or reassembly of the lamp system. Should such a repair or replacement require an on-site service call, the Purchaser shall bear the responsibility for all costs and associated expenses. The manufacturer does not assume responsibility for any unauthorized repairs to its products, even though defective, and unauthorized parts or repairs shall void this warranty.

This warranty is the only warranty given with the manufacturer's products. There are no warranties of merchantability of fitness for a particular purpose or other warranties or representations of any kind, express or implied, which are made with respect to these products.

The remedies of the Owner set forth in this warranty are exclusive. In no event shall the buyer be entitled to recover for incidental, special or consequential damages, arising from the sale or use of these products, including but not limited to loss of profits or revenue, other commercial losses, inconvenience, delay, labor, repairs, or other cost of rental or replacement equipment.

This warranty excludes any and all incidental damage that may be caused by xenon bulb explosions. The bulbs used in manufacturer's products are not included in this warranty; however, they are covered by the bulb manufacturer's warranty.

