

# INSTRUCTION MANUAL

## XENON POWER SUPPLY

3000 - 5000 Watt

220 Volt Equipment Type

6280116

Rev. July 2006



### **STRONG INTERNATIONAL**

a division of Ballantyne of Omaha, Inc.

4350 McKinley Street

Omaha, Nebraska 68112 USA

Tel 402/453-4444 • Fax 402/453-7238

[www.strong-lighting.com](http://www.strong-lighting.com)

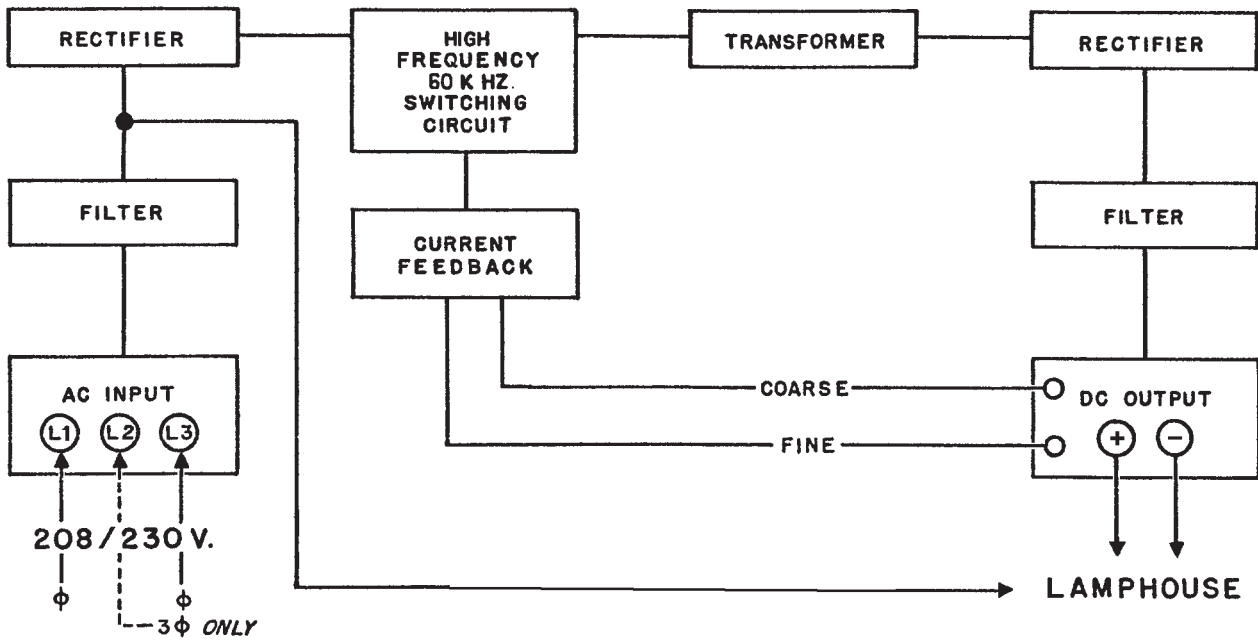

SEE "INSTALLATION" INSTRUCTIONS

## PREFACE

THIS STRONG switching-type power supply is designed to operate a xenon lamp in all lighting applications for Strong Britelight lampheads. This unit will operate all xenon lamps rated from 3000 to 5000 watts throughout their full operating ranges (30-35 V.DC, 75-140 A.DC). The power requirement for this unit is 208/230 (200-240) V.AC, 30 amperes single or three phase, 50/60 Hertz.

INCOMING LINE POWER is transformed from 208/230 volts AC to a low voltage, high current DC output. The incoming AC line is filtered to eliminate noise and is then converted to DC. This DC voltage is switched on and off by a solid state switching circuit, and converted to a 60 kHz. square wave. The square wave is fed into output transformers to provide low voltage and high current. Rectifiers convert the 60 kHz. signal to DC, and the output is filtered to eliminate noise and ripple. Output to the xenon lamp is adjustable through use of potentiometers. A three ampere circuit breaker protects the control circuit in the event of a lamphead component malfunction.

PROTECTIVE CIRCUITS include a high temperature limit switch and under- and overvoltage detection. The thermal switch will open and interrupt power supply operation if internal temperatures exceed 175° F. (80° C.). A drop in AC line voltage, reducing AC supply to inadequate levels, or a high voltage AC spike, will also disable the power supply until the voltage is corrected.

A MULTI-PIN RECEPTACLE is standard on units supplied for use with Strong Britelights. A lamphouse termination panel may be ordered as an option for motion picture or studio applications using Strong lamphouses without the corresponding plug.

## NOTICE



REFER ALL SERVICING of this unit to an authorized Strong Equipment Dealer. The Switching-Type Xenon Power Supply employs solid state circuitry requiring sophisticated diagnostic equipment not generally available to field service personnel. Hazardous high voltages exist within the power supply cabinet.



## INSTALLATION - OPERATION



**CAUTION:** This equipment operates at hazardous voltages, and should be operated by qualified, trained personnel *only*. Do not remove power supply cover panels when the unit is energized.



When positioning the power supply, allow several inches clearance around the power supply cabinet for unobstructed air flow. If the intake or outlet grilles are blocked, thermal switches will shut the unit off to prevent heat damage.

Connect the lamphead DC and control leads to the output side of the power supply prior to connecting to AC power. Lamphead to power supply connections, terminated in a multipin plug, are illustrated on the INTERCONNECTION DIAGRAM in the lamphead instruction manual. DMX connections are labeled; a DMX “through” connector permits “Daisy Chaining” to other fixtures.

Power leads run to the unit must be of the correct size and type to conform to local codes. Shield in conduit as required. The power supply will not energize until the circuit breakers on the side of the cabinet are placed in the ON position.

Incoming AC power connects to a four-prong, female VEAM plug which mates to the AC receptacle mounted to the power supply. Connect 208/230 V.AC three phase input to terminals A, B, and C. If operation is limited to 4000 watts, the unit may be connected to single phase using terminals A and C only. Single or three phase neutral is not required for installation of this unit. Attach an adequate earth ground to the ground terminal D.

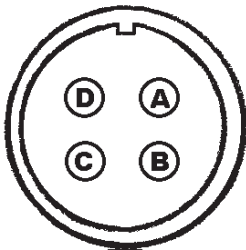

Long Pin (D)  
Ground

In areas using 380/440 V.AC three phase power (Europe, etc.), connect the unit for single phase operation only, using (1) brown *phase* line on A and a blue *neutral* on C. AC input as measured across connector terminals A and C must not exceed 240 V.AC. Attach an adequate earth ground (yellow/green wire) to the ground terminal D.

See the warranty information packed with the xenon bulb for correct operating current. Do not, at any time, exceed the maximum current level specified by the bulb manufacturer.

Current output to the lamp is set through use of the adjustment potentiometers. A potentiometer printed circuit board assembly (6270028) is connected directly to the current control receptacle and is easily accessible on the outside of the cabinet.

## INSTALLATION - OPERATION (continued)

Check the lamp current upon the first bulb ignition, and adjust the current control potentiometer to set the desired bulb current. Rotate the potentiometer clockwise to increase current, or counterclockwise to reduce current. A second (fine) adjustment potentiometer is included for output changes in small increments. The PC board is marked *coarse* and *fine* to identify the (2) potentiometers.

In addition to the switching circuit breaker on the side of the cabinet, a POWER rocker switch permits switching the lamp ON or OFF while leaving the cooling fans operating. The two-position momentary FOCUS switch operates the lamphouse focus motor on units including this feature. See Pages 8 and 9 for details on DMX operation

Optional Lamphouse Termination Panel as supplied for units without Multipin Connector Assembly.

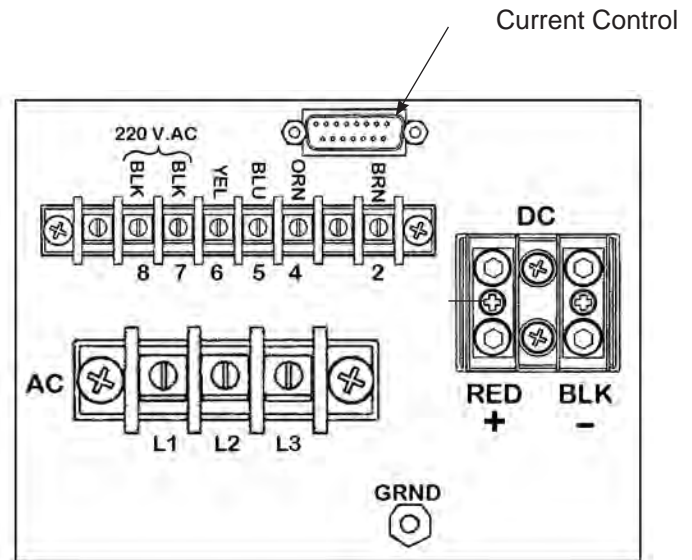
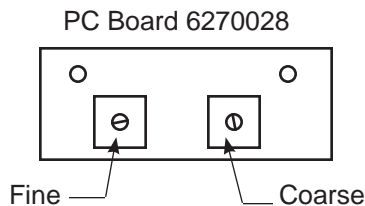

## MAINTENANCE

The power supply requires very little service to insure correct operation. Periodically check all electrical connections for tightness and condition, especially those in the DC circuit. Discolored terminals may indicate oxidation which will increase resistance.

Clean the ventilation inlet and outlet grilles on a regular basis to insure good air flow. Thermal switches mounted to the power supply will interrupt operation of the power supply in the event of overheating.

The blower motors are permanently lubricated. The power supply cabinet includes (2) blowers and requires operation of both *fully functional* blowers for correct operation. In the event of a blower failure, a replacement blower must be installed immediately.

Service interruptions because of low (below 200 V.) or high (over 240 V.) AC input require adjustments to the AC supply line. To protect the equipment, voltage level protection *cannot* be bypassed.

## INDICATOR LIGHTS

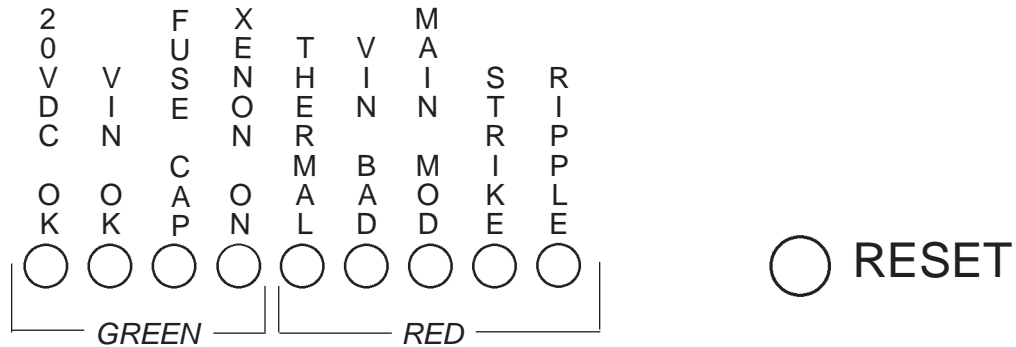

WHEN ALL FOUR of the green indicator lights are glowing, the power supply is trouble-free and operating. One or more red lights, when glowing, indicates that a problem exists, and disables operation of the power supply. The red light(s) latches and remains glowing until the RESET button is depressed after correcting the problem.

### GREEN LIGHTS:

**20 VDC OK:** Indicates that the control board is receiving the correct DC input.

**VIN OK:** Indicates that the AC input voltage is within the correct range (200-240 V.AC).

**FUSE CAP:** Indicates that the fuses on the primary board are good.

**XENON ON:** Indicates that the lamphouse interlock circuit is complete, and that DC power is being applied to the xenon bulb.

### RED LIGHTS:

**THERMAL:** Indicates that the unit is overheated.

**VIN BAD:** Indicates that AC input voltage is above or below the correct range (200-240 V.AC).

**MAIN MOD:** Indicates that one or more fuses on the primary boards have opened.

**STRIKE:** Indicates that the xenon bulb is requiring excessive ignition pulses.

**RIPPLE:** Indicates excessive ripple in the output current.

## TROUBLESHOOTING

*See Lamphed Manual Before Troubleshooting Power Supply*

### **Lamphed Blower(s) Not Operating; Power Light “ON,” Circuit Breaker “ON”**

1. Lamphed interlock switch open. See lamphouse manual.
2. Three ampere circuit breaker is tripped. Press to reset.
3. Improper AC input connection. Check AC voltage at contactor terminals; should read 200 - 240 V.AC across input terminals (A, B, C for three phase; A & C only for single phase).
4. Defective circuit breaker. Check resistance across circuit breaker CB1 with supply OFF; should measure 0 Ohms. Replace as required.
5. Defective filter board. Check across each leg of the filter board input and output; voltage should measure 200 - 240 V.AC. Replace as required.
6. Lamphouse blower fuse blown (if applicable). See schematic in lamphouse manual.
7. Defective lamphed blower. Check AC voltage at blower motor inputs; should measure 200 to 240 V.AC. Replace if defective.
8. Current Control potentiometer assembly not connected; pico fuse (early model potentiometer assembly) open. Repair or replace.

### **Lamphed Blower(s) Operate, but Power Supply GO Indicator does not glow**

1. Possible open interlock switch in lamphouse or power supply; check air flow and interlock switches and interlock connections.
2. Defective control PC board. Check for 20 V.DC at U14 pin 2 & ground test point on power supply control board. Check for 120 V.AC on PL5. If voltages present and GO light does not glow, *consult factory*.
3. Power supply overheated (red TEMP light glowing; open thermal switches). Check for correct blower operation and unobstructed air flow in power supply cabinet. Thermal switches will open if temperatures inside the power supply cabinet exceed 175° Fahrenheit (80° Celsius).

### **Xenon Lamp Fails to Ignite; Blowers Operating, GO Indicator glowing**

1. Defective or expired xenon lamp. Replace as required.
2. Potentiometer assembly turned down; potentiometer defective.
3. Check DC no load output voltage. Should measure 150 - 180 V.DC; if lower, *consult factory*.
4. Faulty DC output connection. Check and correct as required. Tighten connections securely.



## TROUBLESHOOTING (continued)

### Xenon Lamp Fails to Ignite; Blowers Operating, GO Indicator glowing (continued)

5. No DC voltage output. Blown fuse on primary board; allow power supply twenty minutes (power OFF) to discharge capacitors before removing fuse. Good fuse should measure 0 Ohms; replace as required. If fuse blows repeatedly, *consult factory*.
6. Defective igniter. Allow unit to cool and attempt re-ignition. Check DC voltage at output; should measure 150 V.DC or higher. If voltage is correct, check DC connections in lamphouse and power supply; tighten securely. Attempt re-ignition; if no ping is audible in the lamphouse, replace igniter. If ping is audible, but no flash is apparent, check for lamphouse DC lead shorting to ground. If ping is heard and arc is visible between bulb electrodes, and bulb fails to ignite, replace bulb.

### Xenon Lamp Goes Out During Operation (Intermittent Operation)

1. Defective or expired xenon lamp. Replace as required.
2. Fault in lamphouse interlock circuit. See lamphouse manual.
3. Power supply overheated. Check for blower operation and unobstructed air flow in power supply enclosure. Thermal switches will open if heat sink temperatures exceed 175° Fahrenheit (80° Celsius).
4. Brown-out (voltage drop) or spike (voltage surge) in AC supply. Measure AC source.

### No Output Current Adjustment

1. Defective power module. *Consult factory*.

Xenon Power Supplies, Lamphouse Igniters, and other components shipped to the factory for credit, repair or repair/exchange must be returned through an authorized Strong Equipment Dealer. Contact your Strong Dealer for a **Return Authorization** and instructions prior to shipping any goods to Strong.

## DMX Operation Mode

In DMX operation, the fixture will be used in an installation where it is desirable to control several fixtures and related accessories with the use of sophisticated lighting programs or equipment (DMX source). This is most suitable for applications where all aspects of lighting are to be fully digitally programmed and executed. Typical installations require fixtures and related accessories to be “addressed” so that they may be controlled with a DMX source.

- 1) Plug the power cord into a power source and push the power switch/ circuit breaker to the ON position.
- 2) The display will energize and show the TIMER mode - select ADDRESS mode by depressing the FUNCTION SELECTION BUTTON (diamond button). The display should read “A” followed by three digits.
- 3) Press the NUMERIC SELECTION BUTTONS (triangles) until the display reads “A” followed by the DESIRED FIXTURE ADDRESS.
- 4) Plug the DMX cable from the DMX source into the INPUT port on the rear cover of the fixture.
- 5) When DMX 512 signals are detected (DMX level above 80%/ 204 - 255), a relay within the fixture will close and the lamp will ignite. The display will also show a decimal point between the “A” character and the first “0” digit when DMX is detected.
- 6) When signals from the DMX source are detected (DMX level below 20%/ 000 - 051) the fixture relay will open and the lamp will extinguish, but the fixture will remain ON.

In most applications where DMX operation is utilized, it is common to “daisy-chain” or link several other fixtures and accessories together. This eliminates the need to connect individual cables from the DMX source to each item.

- 7) Plug DMX cable into the THROUGH port on the rear cover of the fixture.

Connect opposite end into next desired DMX accessory or fixture. The UV fixture will monitor incoming signals, process those to which it is addressed, and pass all other signals through (use terminator at last fixture).

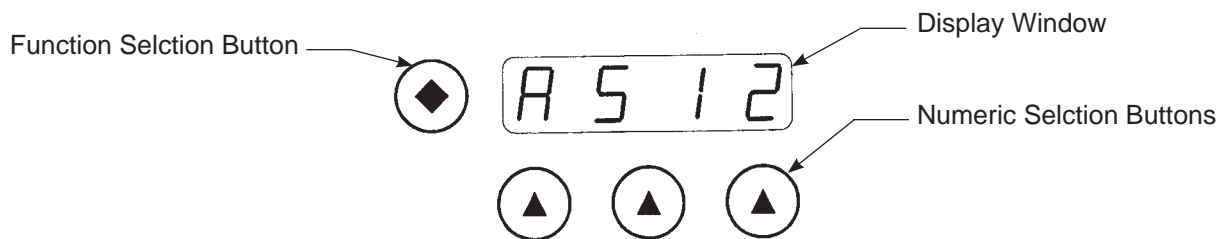

Display window for DMX Mode (Example Display)

## Lamp Hour Meter Mode

The display can be changed to a resettable hour meter that keeps a memory of total elapsed lamp hours while ignited. This feature is useful in determining when a lamp should be replaced. Output and performance will dramatically decrease while the possibility of lamp failure will increase if the lamp is allowed to operate past its maximum rated life.

The HOUR METER mode will *always* display 4 digits, between “0000” and “6535” (*unlike the DMX ADDRESS mode that will display an “A” character followed by 3 digits*). The timer can reach a maximum “6535” hours, and will rollover to “0000” when it is exceeded.

1. Plug the power cord into a power source and push the power switch/ circuit breaker to the ON position.
2. The display will energize and show the HOUR METER mode. The display will show 4 digits total, “0000” to “6535”. The fixtures should arrive from the factory preset at “0000” when the HOUR METER mode is active.
3. To reset the HOUR METER to “0000”, depress all three NUMERIC SELECTION BUTTONS (triangles) together and hold for approximately 5 seconds or until the display shows “0000.”

The display (when active) will show a moving decimal point when the HOUR METER mode is active and the lamp is operating. The decimal point will float across the bottom of the display from the left to right. This indicates the relay within the fixture is closed and the lamp is ON.

When the HOUR METER mode reaches 1,000 hours (elapsed lamp life), the display (when active) will move from a steady state to flashing state. This indicates the lamp has reached its maximum rated life and should be changed. Follow the instructions for resetting the timer to have the display reset to a steady state.

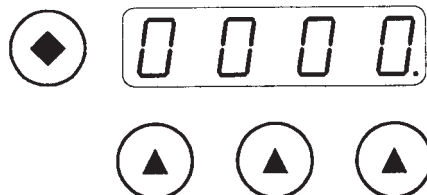

Display window for the Lamp Hour Meter Mode (Example Display)

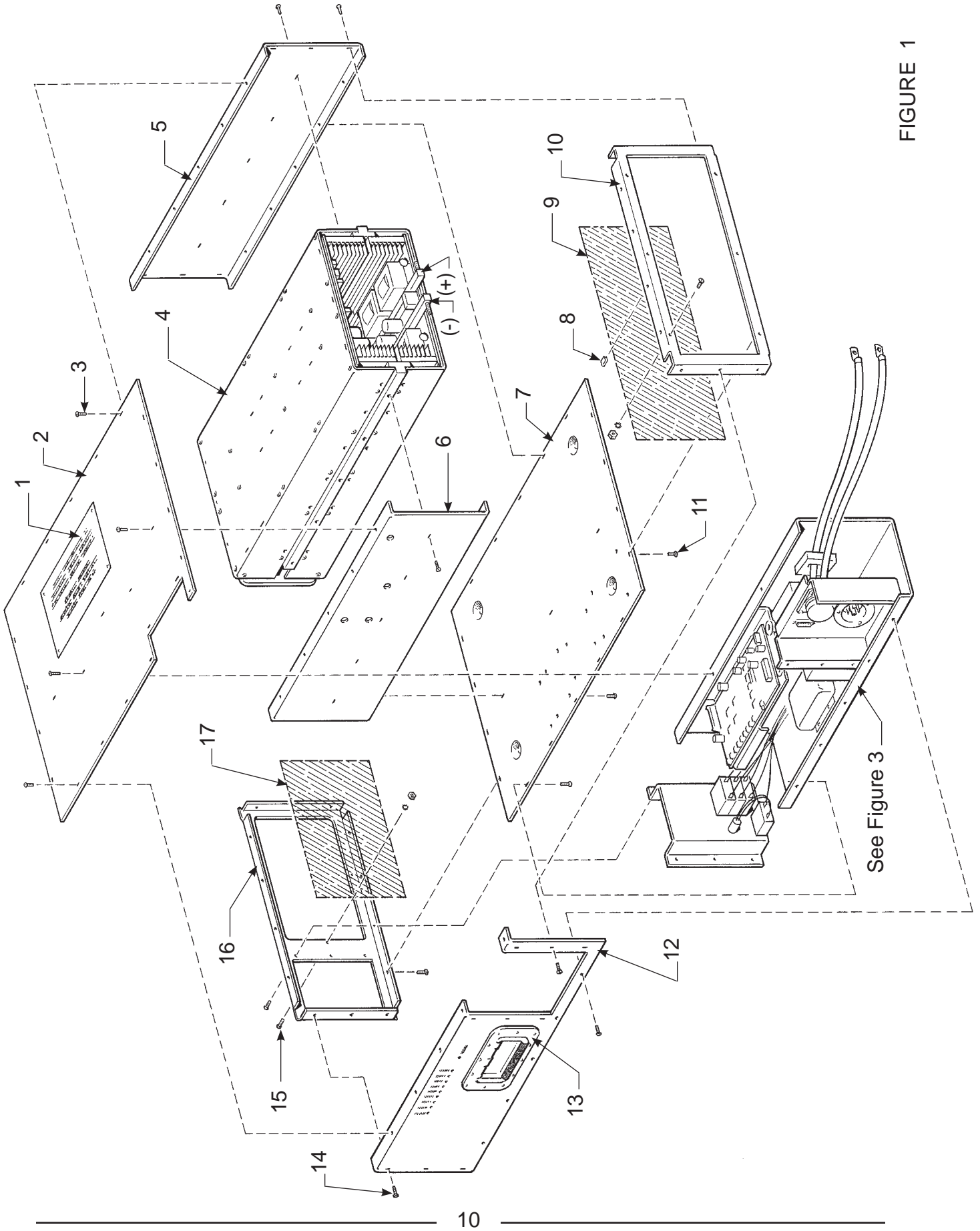

See Figure 3

FIGURE 1

## PARTS LIST

Figure 1

<u>Item</u>	<u>Part No.</u>	<u>Description</u>
1	6280036	Name & Data Plate
2	6200011	Top Cover Plate
3	4080370	Screw, 8-32 x 3/8" Phillips Head
4	6200024	Power Module Assembly (see Figure 2)
5	6200010	Side Panel
6	6200020	Center Brace Panel
7	6200012	Base Plate
8	4088001	Hexnut, 8-32
9	6200034	Blower Outlet Grille
10	6200027	Vent Bracket
11	4080370	Screw, 8-32 x 3/8" Phillips Head
12	6200022	Top Panel
13	77271000	Handle, Spring-Loaded
14	4080370	Screw, 8-32 x 3/8" Phillips Head
15	4080370	Screw, 8-32 x 3/8" Phillips Head
16	6200026	End Panel & Vent Bracket
17	6200028	Blower Intake Grille

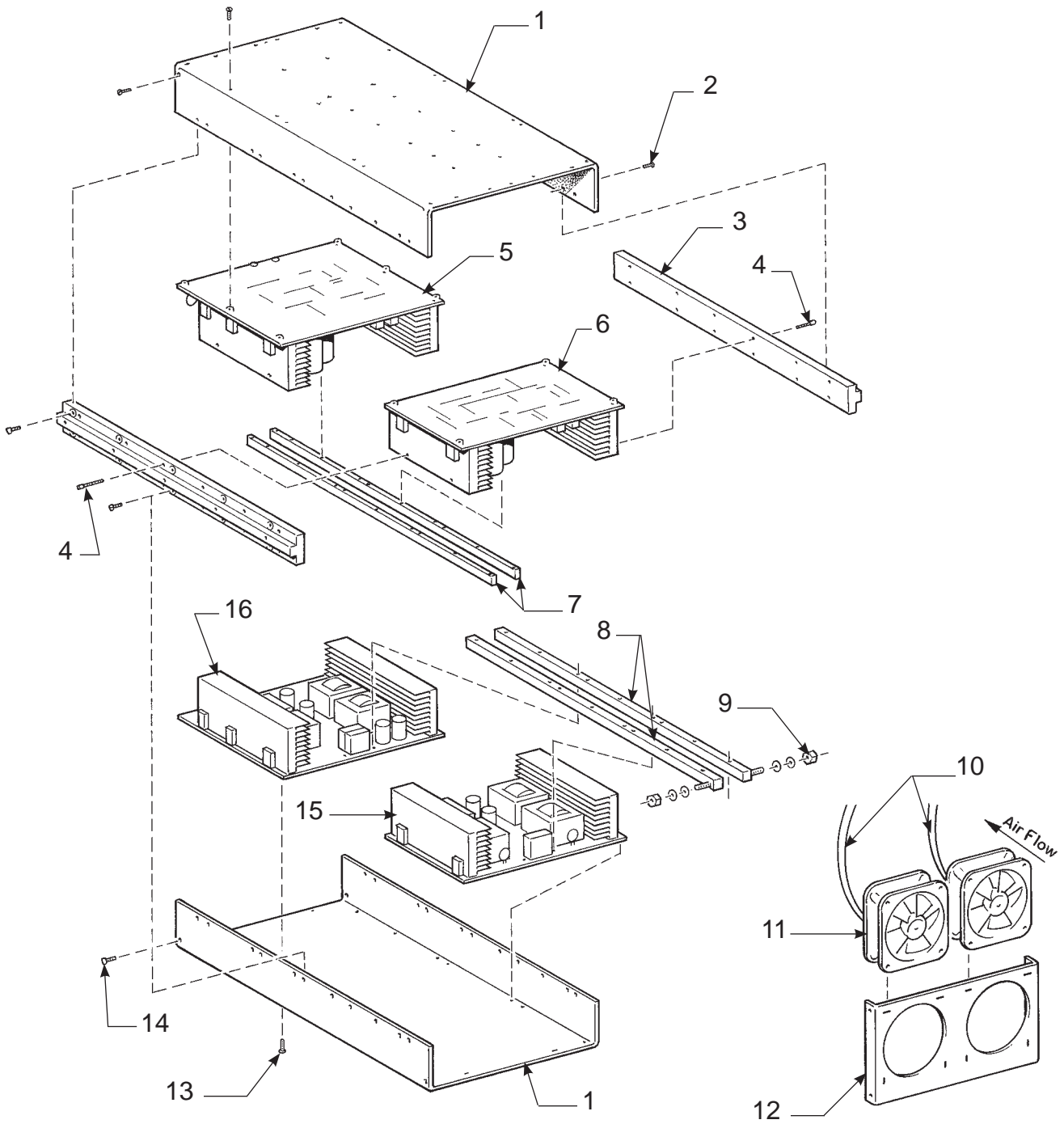
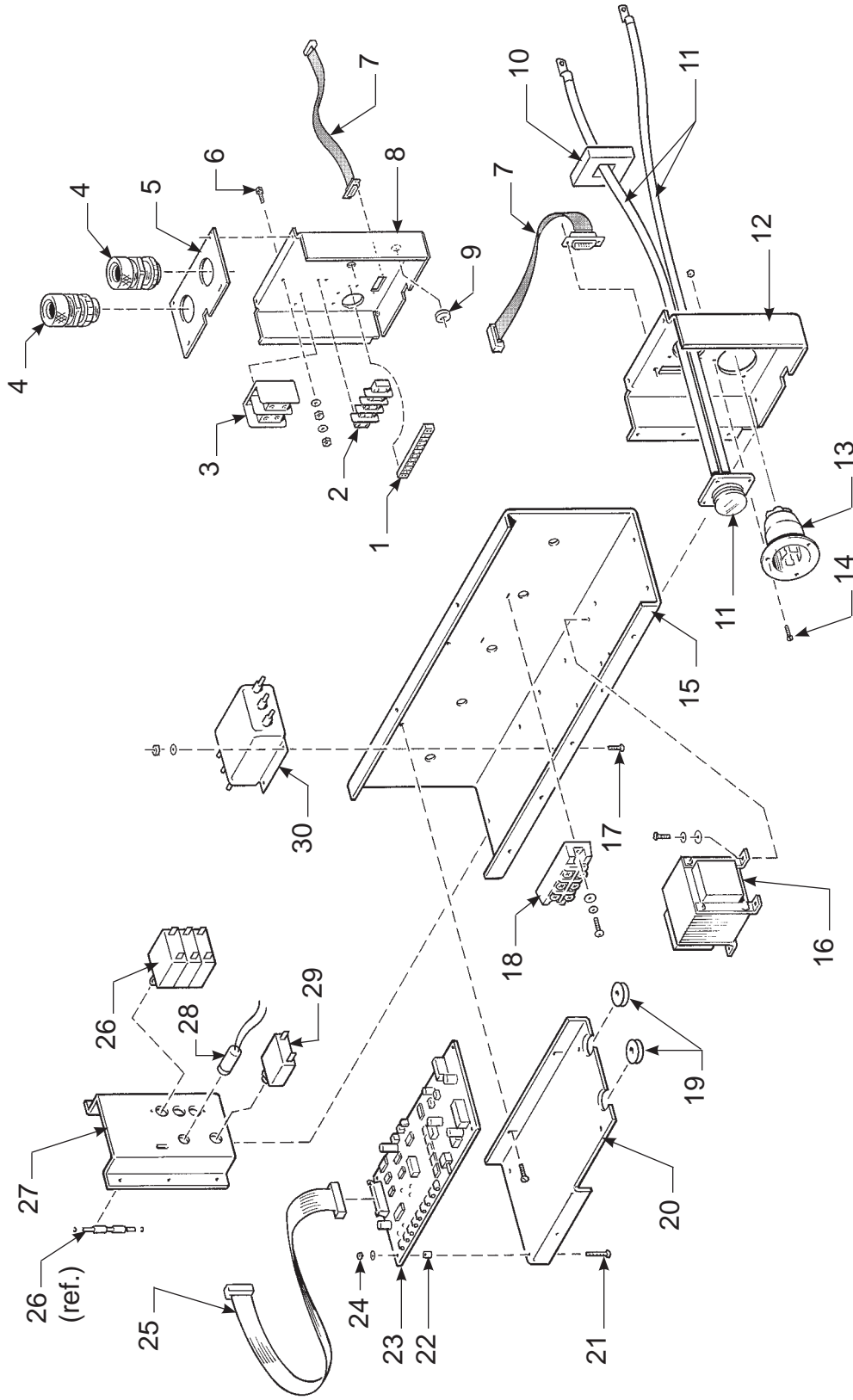

FIGURE 2

## PARTS LIST

Figure 2

<u>Item</u>	<u>Part No.</u>	<u>Description</u>
1	6200013	Faraday Shield (2 req'd.)
2	4060250	Screw, 6-32 x 1/4" Bind Head
-	4067001	Lockwasher, #6
3	6200008	Insulated Support
4	4080502	Screw, 8-32 x 1/2" Socket Head
5	6270014	Primary PC Board, Section 2
6	6270015	Primary PC Board, Section 1
-	2121042	Fuse, 10 Ampere (2 req'd.)
7	6200025	Primary Buss Bar
8	6220023	Output Buss Bar
-	4061001	Bar Mounting Screw, 6-32 x 1" Brass
9	4135060	Locknut, 1/4-20
-	6170002	Spring Washer
10	88253000	Fan Cord & Molded Plug
11	6198002	Fan, 115 V.AC, 50/60 Hz.
-	4060620	Fan Mounting Screw, 6-32 x 1/4" Bind Head
-	61127000	Fan Mounting Clip, 6-32
12	6200009	Fan Panel
13	4060252	Screw, 6-32 x 1/4" Bind Head
14	4080370	Screw, 8-32 x 3/8" Phillips Head
15	6270013	Secondary PC Board, Section 1
16	6270011	Secondary PC Board, Section 2



Items 1-9: Hardware Models  
 Items 11, 12, 13: Plug-In Models

CURRENT CONTROL (to Item 7):  
 6270028 Plug-In PC Board Assembly (no Cable)  
 6270032 Potentiometer & Cable Assembly (Remote)

FIGURE 3



## PARTS LIST

Figure 3

<u>Item</u>	<u>Part No.</u>	<u>Description</u>
1	2162006	Barrier Strip, (8) Terminals
2	6162001	Barrier Strip, (3) Terminals
3	6162012	Barrier Strip, (2) Terminals
4	6198039	Cord Grip Bushing
5	6200055	Bushing Plate
6	4250756	Ground Screw, 1/4-20 x 3/4" Hex Head
-	4258005	Hex Nut, 1/4-20
-	4257001	Lockwasher, 1/4"
7	6270033	DB Connector & Ribbon Lead Assembly
8	6200047	Mounting Bracket, Input/Output Terminals
-	6200048	Cover, Input/Output Terminals (not shown)
9	4198039	Grommet, Black Rubber
10	6270026	LEM Harness
11	6270044	MS Connector Assembly
12	6200035	Input/Output Mounting Bracket
13	6140007	AC Input Receptacle, 30 Ampere Hubbell
14	4080370	Screw, 8-32 x 3/8" Phillips Head
15	6200021	Chassis
16	6270023	Stepdown Transformer, AC Control
-	4080375	Mounting Screw, 8-32 x 3/8" Pan Head
-	4087101	Flatwasher, #8
17	4080375	Screw, 8-32 x 3/8" Pan Head
18	6117001	Diode Bridge
-	4080871	Screw, 8-32 x 7/8" Pan Head
19	4198045	Grommet, Black Rubber
20	6240120	Mounting Plate, Contol PC Board
21	4151021	Screw, 4-40 x 1/2" Bind Head
22	5156002	Nylon Spacer
23	6172015	Control PC Board Assembly (specify 4 or 7 kW)
24	4135003	Hexnut, 4-40
-	4170011	Lockwasher, #4
25	6171013	Ribbon Cable Assembly
26	6161001	Circuit Breaker, 30 Ampere, 3 Pole
27	6200030	Circuit Breaker Mounting Plate
28	6130001	Indicator Light, Red
29	2121039	Fuse Holder (21-21017 Fuse, 3 Ampere <i>not shown</i> )
30	6150004	Line Filter, <i>as shown</i> ; Alternate: (2) 6198035

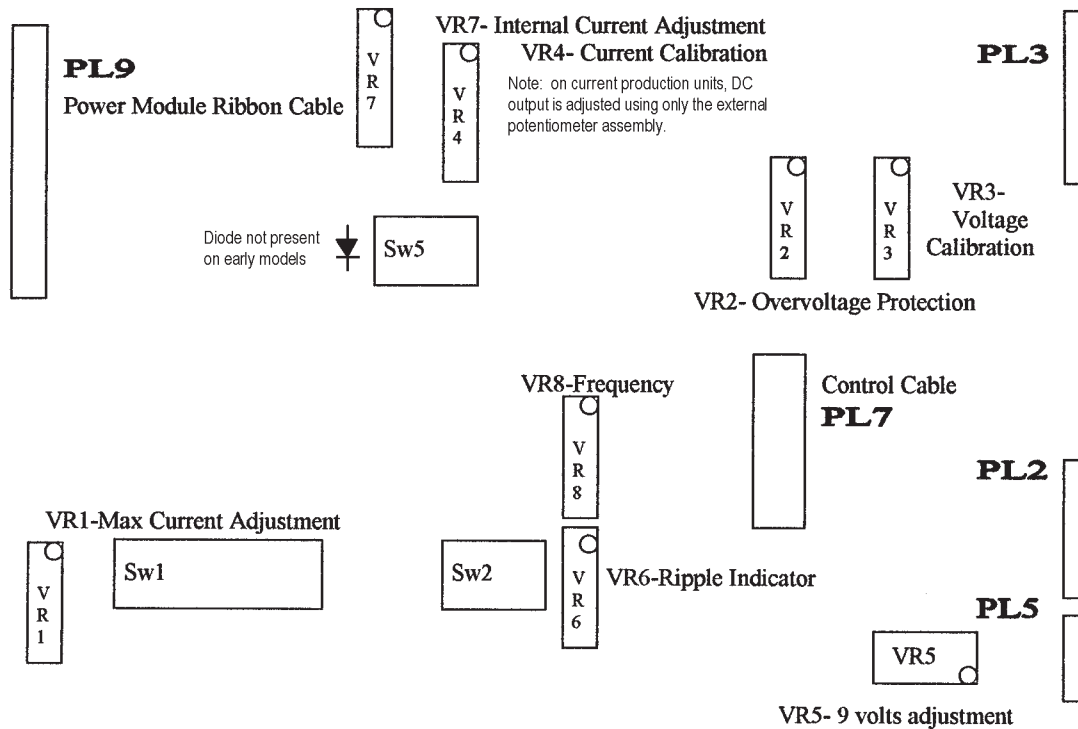

NEG  
○  
○  
POS

Normal Switch Setting

- SW1**
- on 1. (a) Master Enable--- If **OFF** will disable SW1 2 thru 5
  - on 2. (b) Aux. Volts Good
  - on 3. (c) Input Volts Good
  - on 4. (d) Power Section Good
  - on 5. (e) Xenon On
  - on 6. (f) Master Override- If **OFF** will allow supply to operate
  - off 7. (g) Short Circuit---If **ON** will shut supply off when the output is shorted.
  - off 8. (h) Not used
- If switches are **ON**, unit will operate only if L.E.D.'s light.
- SW2**
- on 1. (a) Master Inhibit---In the **OFF** position--will disable switches SW2-2, SW2-3 and SW1-7
  - on 2. (b) Thermal Inhibit---In the **ON** position--will shut supply off, if too hot.
  - off 3. (c) Open circuit, short circuit or strike failure- If **ON** position-- will turn power supply off.
  - on 4. (d) Selects the external Current Control
- SW5**
- off 1. (a) Overvoltage shutoff--- If **ON** -will turn power supply off if voltage goes high
  - on 2. (b) Selects local Current control --**On** is for control at PCB. **OFF** is for External Control.
  - on 3. (c) Selects local master---Must be On unless the power supply is a slave unit.
  - off 4. (d) Remote master---Must be turned on if unit is a master and there are slaves connected to it.

<b>PL7</b>	<b>PL2</b>	<b>PL3</b>	<b>PL 5</b>	<b>DB 15 Connector</b>
Pin #	Pin #	Pin #	Pin #	Pin #
1. Com signal	6. } <b>9 VAC</b>	1. -1.2 V	1. 110 V common	1. Com Signal
2. V signal ( 20 mv/v)	7. }	2. +20 V	2. 110 V go signal	2. I Signal (20mv/a)
3. I signal ( 20 mv/a)	9. } <b>18 VAC</b>	3. Com. signal		3. GO Signal Input
4. 9v power return	10. }	4. DCCT signal V		4. Power Section Fault
5. Go signal input (+9v)		5. I DCCT signal		5. Inhibit Fault
6. +9v out		6. } Master/		6. (not used)
7. Power Section fault		7. } Slave		7. +9 V.
8. Enable fault				8. +9 V. Return
9. Inhibit fault				9. V Signal (20 mv/v)
12. I adjust fine				10. +9 V. Return
13. +9v signal				11. +9 V.
14. I adjust course				12. Enable Fault
				13. (not used)
				14. I Adjust Fine
				15. I Adjust Coarse

FIGURE 4

CONTROL PC BOARD, Component Functions

---

