

SKY-TRACKER

PROMOTIONAL SEARCHLIGHTS

MOTORIZED SEARCHLIGHTS

Models STX-1, STX-4

INSTRUCTION MANUAL

Rev. April 2002

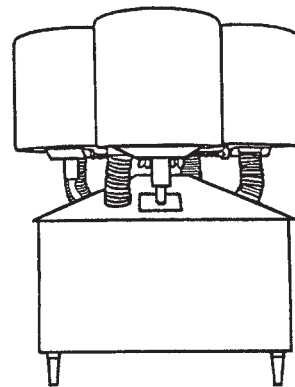
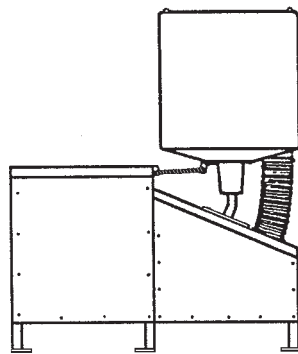

4350 McKinley Street • Omaha, Nebraska 68112 USA
(800) XENOTECH • www.xenotech.com

TABLE OF CONTENTS

1.0	INTRODUCTION	1
1.1	Model Designation	1
2.0	SAFETY	1
3.0	OPERATION OF THE SKY-TRACKER	3
3.1	Input Power Requirements	3
3.2	Startup and Shutdown	3
3.2.1	Lights “ON”	4
3.2.2	Selective Operation	5
3.2.3	Motion “ON”	5
3.2.4	Shutdown	5
3.3	Hour Meter	5
3.4	Electrical Protection	6
3.5	Transporting	6
4.0	BASE ASSEMBLY - ELECTRICAL COMPONENTS	7
4.1	Control Panel	7
4.2	Main Wire Harness Assembly	8
4.3	Motion Drive Motor	8
4.4	Cooling System	8
4.5	DC Power Supplies	9
4.5.1	Power Supply Contactors	9
4.5.2	Voltage Adjustment Terminal Board	9
4.5.3	Power Diodes	11
4.5.4	Auto Strike Assembly	11
4.5.5	Timer PCB Assembly	12
4.6	Power Factor Correction Capacitors	12
4.7	DC Power and Ignition Cables	12
5.0	BASE ASSEMBLY- MECHANICAL COMPONENTS (STX-4)	12
5.1	Motion Drive Train	12
5.2	Motion Assemblies	12
5.3	Timing Belt Idler	13
5.4	Timing Belt Tensioning Adjustments	13
5.5	Spring Assemblies	13

5.6	BASE ASSEMBLY - MECHANICAL COMPONENTS (STX-1)	15
5.7	Motion Drive Train	15
5.8	Motion Assembly	16
5.9	Drive Chain Tension Adjustment.....	16
6.0	LAMPHEAD ELECTRICAL COMPONENTS	16
6.1	Igniter System	16
6.1.1	Primary Transformer	17
6.1.2	R.F. Igniter Transformer	17
6.1.3	Spark Gap and Related Components	17
6.2	DC Power Cables	17
6.3	Cooling Blowers	17
6.4	Thermal Switch	18
6.5	Xenon Bulb	18
7.0	LAMPHEAD MECHANICAL COMPONENTS	18
7.1	Reflector Assembly	19
7.2	Lower Bulb Support	19
7.3	Air Plenum/Duct	19
7.4	Upper(Anode) Bulb Adapter	19
7.5	Upper Bulb Support Spider and Adjustment Assembly	20
7.6	Housing Assembly	20
8.0	BULB INSTALLATION	20
8.1	Final Focus and Beam Alignment	22
9.0	BULB REMOVAL	24
10.0	ROUTINE SERVICE AND MAINTENANCE	24
10.1	Periodic Maintenance	24
10.1.1	Base	24
10.1.2	Xenon Lamphead Assemblies	22
	TROUBLE SHOOTING GUIDE	26
	WIRING DIAGRAMS	27
	BULB HISTORY RECORD	30
	LIGHTING PRODUCT WARRANTY	31
	BULB RETURN POLICY	32
	PARTS DRAWINGS	33

NOTICE

PATENT POSITION

The Sky-Tracker is a motorized, high-intensity, single or multiple head searchlight system, which was originated by Sky-Tracker of America, Inc. and is proprietary to Xenotech-Strong International.

Patents, owned by Xenotech-Strong International are either issued or pending in this and related concepts.

TRADEMARK

The name, "Sky-Tracker" is a trademark owned by Xenotech-Strong International, and has been registered with the U.S. Patent Office.

COPYRIGHT

The material contained in this manual is the property of Xenotech-Strong International, and may not be reproduced, in full or in part, without the written consent of Xenotech-Strong International.

Strong International is a division of Ballantyne of Omaha, Inc.
4350 McKinley Street • Omaha, Nebraska 68112 USA

SKY TRACKER SPECIFICATIONS

STX1					
V.AC	Iac	V.DC	Idc	WATTS	PHASE
208-237	25-22	20-33	100-60	2 kW	3
380-440	14-12	20-33	100-60	2 kW	3
208-230	35-30	22-33	100-60	2 kW	1
208-237	28-24	25-35	160-115	4 kW	3
380-440	16-13	25-35	160-115	4 Kw	3
208-230	35-30	40-50	100-160	7 kW	3
380-440	20-17	40-50	100-160	7 kW	3

STX4					
V.AC	Iac	V.DC	Idc	WATTS	PHASE
208-237	100-88	20-33	100-60	2 kW	3
380-440	56-48	20-33	100-60	2 kW	3
208-230	112-96	25-35	160-115	4 kW	3
380-440	64-52	25-35	160-115	4 kW	3

1.0 INTRODUCTION

The Sky-Tracker is an original proprietary lighting system developed specifically for the display advertising industry and related technologies. Each unit is designed with highly reliable mechanical, electrical and optical components to insure extended, trouble-free performance.

An outgrowth from space age and military advanced technology applications, the Sky-Tracker provides an easily transported base unit for the mounting and control of high intensity searchlight(s). Searchlights for the four-beam system simultaneously move outward and downward from a vertical starting position in a sweeping motion. They continue in a "cloverleaf" pattern, converging momentarily at the vertical position to produce an intense central column of light. The repetitive sweeping motion of the beams can be seen for miles in every direction, pinpointing the location of the attraction.

Each light combines a xenon plasma arc light source with a precision electroformed metal reflector to produce a collimated beam of white light (virtually identical to sunlight; color temperature of 5600° Kelvin).

NOTE: This manual is intended to address the information requirements for all "STX" models. Not all information is appropriate for both the STX-4 and STX-1 models, or for all wattage lampheads. Be sure to apply the sections specific to your system.

1.1 MODEL DESIGNATION

Sky-Trackers are available in four-beam and single beam models, and in two intensity levels. Power requirements vary with model designation (also see section 3.1). The models available and performance characteristics are as follows:

MODEL	NUMBER OF BEAMS	WATTS PER LAMP	CANDLE POWER PER BEAM
STX-4 – 2000	4	2000	208 MILLION
STX-4 – 4000	4	4000	332 MILLION
STX-4 – 7000	4	7000	600 MILLION
STX-1 – 2000	1	2000	208 MILLION
STX-1 – 4000	1	4000	332 MILLION
STX-1 – 7000	1	7000	600 MILLION

NOTE: The components that differ between the models are identified in the sections that follow.

2.0 SAFETY

The concept of achieving maximum safety through knowledge and understanding is basic to Xenotech-Strong International. Whether applicable to its own personnel, those of the dealer, representative, operator, servicing agency or to any member of the general public who may be exposed to or associated with the operation of a Xenotech-Strong International product.

Safety features and concepts are designed into every Xenotech-Strong International product and component regardless of whether its function is mechanical, electrical, or optical.

Since Xenotech-Strong International has no control over the manner in which its products are installed, operated, maintained, or utilized after the product leaves the manufacturing facility, it can not be held responsible for any injuries resulting from improper installation, use, inadequate maintenance, or any other condition beyond its control.

It is the intent of this manual to call to the attention of the owner, operator, and service technician, any and all hazardous areas or conditions which could lead to operational problems or injury and to outline proper and recommended procedures to prevent any such occurrence.

Throughout this manual, the following nomenclature will be utilized to call to the attention of the reader any potential hazards related to operation or maintenance.

CAUTION

The word **CAUTION** is utilized (preceding certain sections in this manual) to call attention to an area of particular importance, where failure to follow the specified Xenotech-Strong International procedure may result in improper operation of the device. And also, may impair the effectiveness or utility of the device, cause a shortened effective lifetime of components, or in any way lead to premature or ultimate failure of the device to perform to its original design standards and expectations.

The normal warranty will be voided in instances where it is determined that any component of the Sky-Tracker has been damaged or has failed due to failure to follow procedures or instructions contained in this manual.

DANGER

This designation is utilized preceding any section within this manual where the operations described could expose anyone to the possibility of physical danger or injury of any kind. It is the responsibility of the owner, operator, or service technician to become familiar with all such **DANGER** sections and/or situations, and to follow the specified procedures and instructions explicitly, and to otherwise use all prudent and responsible care to prevent injury.

The completely assembled and operational Sky-Tracker has all rotating parts (drive motor, drive chain, drive belt, etc.) and all electrical and optical components contained within closed and secured housings. The Sky-Tracker Lamps move relatively slowly (nominally 6 seconds per cycle). At this slow rate, there is little possibility of being “hit” or injured by the moving Sky-Tracker Lamps. Some precautions may be taken to avoid the possibility of anyone being “bumped” by the units during operation. It is recommended that, if the unit is operated at ground level in areas where crowds may be present, a rope barrier or equivalent barricade be established to keep the general public away from the moving Sky-Tracker.

As is the case with all intense light sources, it is not advisable to look directly into the light source or into the light beam. It is the responsibility of the operator to see that the necessary rope barriers or other barricades are positioned suitably to prevent passers-by or any member of the crowd from looking directly into the light beams from a close distance.

3.0 OPERATION OF THE SKY-TRACKER

3.1 INPUT POWER REQUIREMENTS

CAUTION

Each Sky-Tracker model has been designed and factory tested to operate satisfactorily with an input power source as specified below. The DC lamp power supplies, incorporated within each Sky-Tracker base assembly, can be adjusted to compensate for input voltages which are slightly lower or higher than nominal. Details of this adjustment procedure may be found in section 4.5.2 of this manual. It is the responsibility of the owner/operator to determine that proper input power is provided and to make adjustments or corrections as may be required to provide compliance with the requirements set forth below.

CAUTION

Polarity and Grounds must be checked before cable connections are made to the Sky-Tracker. Low voltage conditions under the minimum levels specified below, may cause damage to the Sky-Tracker.

MODEL	PHASE	VOLTAGE (±10%V.AC,50/60 Hz)	CURRENT (CIRCUIT BREAKER REQUIRED)	POWER CABLES*
STX-4 – 2000	1	220	100 AMP	# 2 (3)
STX-4 – 2000	3	220	80 AMP	# 4 (4)
STX-4 – 4000	3	220	120 AMP	# 2 (4)
STX-4 – 7000	3	220	160 AMP	# 1 (4)
STX-1 – 2000	1	220	(1 ea.) 35AMP	#12 (3)
STX-1 – 2000	3	220	(1 ea.) 25 AMP	#12 (4)
STX-1 – 4000	3	220	(1 ea.) 30 AMP	#10 (4)
STX-1 – 7000	3	220	(1 ea.) 50 AMP	# 8 (4)

Use 100' (30.5 m) or shorter cables. For cables longer than 100' (30.5 m), go to larger wire sizes.
 * Recommended wire sizes; conform to local codes

3.2 STARTUP AND SHUTDOWN

The operation of the Sky-Tracker controls will be explained in this section. The Sky-Tracker control panel (see Figures 2 & 3) is protected from weather, vandalism, and unauthorized access by means of a locking cover panel (STX-4 models only). The STX-1 control panel is enclosed by a screw cover.

When the input power supply cord is connected and the circuit activated, the green pilot lights (identified as "Input Power") will light and remain lit so long as all input phases are

on. If a pilot light does not come on, it is an indication that input power is not being supplied to that particular phase. On the STX-4 models, when all three lights are lit (two on single phase STX-4 – 2000’s), the unit is “powered” and ready to function. STX-1 units do not have pilot lights.

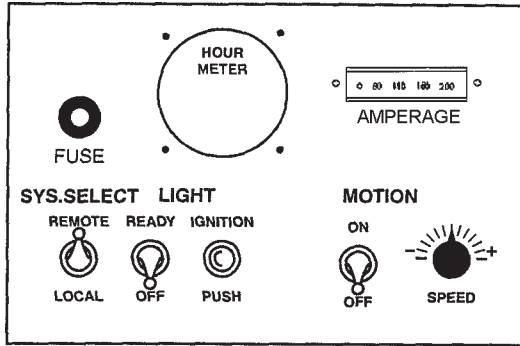

STX-1 CONTROL PANEL (Figure 1)

NOTE: It is not detrimental to the Sky-Tracker units to leave the input power connected (with the pilot lights lit) when the unit is not being used, as long as the “Master” and “Motion” switches are in the “OFF” (down) position.

3.2.1 LIGHTS “ON”

To turn the lights on, move the “Master” switch to the “ON” position (up), and set each of the individual lamp switches to “ON” (up). The lights will automatically ignite within 3 to 4 seconds. In the event that the “autostrike” feature of the Sky-Tracker does not function properly (as evidenced by the lamps failing to light within a few seconds); any lamp can be manually lit by momentarily pressing its respective manual start button located on the control panel.

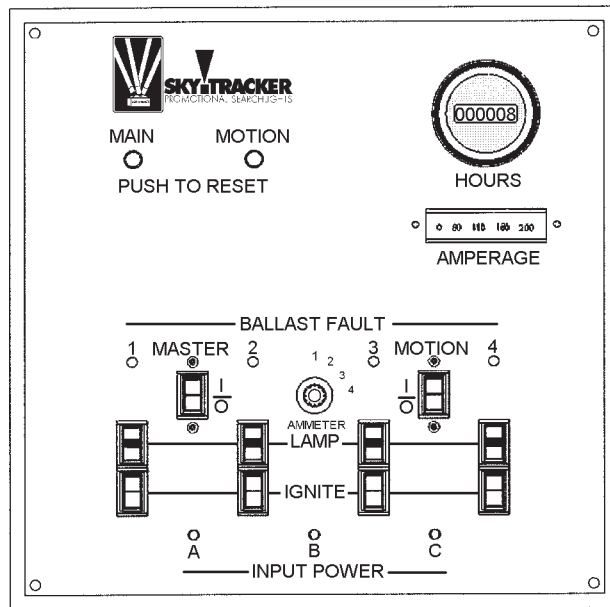

STX-4 CONTROL PANEL (Figure 2)

CAUTION

If the light still fails to light, there is a malfunction, which must be corrected. DO NOT hold the manual “IGNITE” button in for more than a fraction of a second. A momentary push is all that is required. Holding the manual start button in for a prolonged period is *not* necessary for lamp ignition, and can result in failure of the igniter components.

3.2.2 SELECTIVE OPERATION

To choose not to light a particular lamp of an STX-4, the Control Panel has an individual “Lamp OFF” switch for each head. Operation of this switch will disable the indicated lamp.

3.2.3 MOTION “ON”

The motion feature of the Sky-Tracker is initiated by turning the “Motion” switch to the “ON” position (up).

NOTE: If power is interrupted momentarily for any reason and then restored, the motion will automatically resume and each xenon lamp will be re-ignited by “autostrike” or by manually pushing the respective manual start button.

3.2.4 SHUTDOWN

To turn the Sky-Tracker off, reverse the procedures noted in the previous sections. The lights can be turned off and the motion left running, or the motion can be turned off and the lights left in operation, at the discretion of the operator.

It is desirable, however, for prolonged bulb life, that power continue to be supplied for *at least* 10 minutes after the lamps have been turned off to provide required cooling air for optimum cool down of the bulbs after operation. STX-1 systems have a built-in timer that operates the cooling system for 30 minutes after shutdown.

STX-1 systems offer speed and direction control on the front panel.

If desired, the motion of the Sky-Tracker may be stopped in any position by turning off the motion switch at the appropriate time. Because of the inertia of the drive mechanism, a small degree of “coasting” will cause the lights to actually stop at a position slightly past the point at which the switch is turned off. Experimentation and practice by the operator can result in stopping the lights in any desired position.

3.3 HOUR METER

An hour meter, located at the center of the control panel, is provided to maintain a running record of operational hours. The total hours shown on the meter provide a guide to service intervals as well as recording operational lamp hours (required for lamp warranties). Since four individual Xenon lamps are employed on each STX-4 model, individual lamp hours (for lamp warranty purposes) may be recorded on a separate log sheet, furnished at the end of this manual.

Since “motion” is normally utilized in conjunction with the operation of the Xenon lamps, the hour meter serves as a general indication of the total elapsed operating time of the motion drive motor related components.

3.4 ELECTRICAL PROTECTION

Two circuit breakers are provided for protection of the auxiliary and motor circuit. The auxiliary circuit breaker protects the cooling blowers and the control circuits. Each xenon lamp power supply is internally fused. The motion motor is protected with an individual circuit breaker. STX-1 units are provided with a single circuit breaker for all auxiliary circuits, and internal fuses to protect the motor controller.

In the event that any of the above described functions (cooling, lights, and motion) do not operate, the related circuit breaker should be checked (see Troubleshooting). Re-setting the circuit breaker may resolve the problem. Since circuit breakers or fuses are protective devices, failure of a circuit breaker or fuse could indicate an overload or other malfunction. If the circuit breaker or fuse blows again, it is a sign that such a malfunction exists and the cause should be determined and remedied.

CAUTION

UNDER NO CIRCUMSTANCES SHOULD A CIRCUIT BREAKER OR FUSE OF A HIGHER RATING BE SUBSTITUTED IN AN EFFORT TO CORRECT A "CIRCUIT BREAKER / FUSE BLOWING" PROBLEM. TO DO SO MAY NEGATE THE PROTECTION ORIGINALLY INTENDED, CAUSING SERIOUS COMPONENT FAILURE AND VOIDING THE WARRANTY.

3.5 TRANSPORTING

Certain precautions should be taken before moving a Sky-Tracker. Before moving a unit, the lamphead(s) should be brought straight up and, in the case of an STX-4, the four lampheads should be strapped together.

The STX-4, which weighs up to 1200 pounds (545 kg), is most easily lifted for loading by use of a forklift.

CAUTION

Insert forks under the bottom of the main frame ONLY from the left or right of the control panel, never from the rear or front, to prevent damage to the systems on the bottom of the unit.

The Sky-Tracker can also be moved by the use of "optional" casters. It can then be winch-loaded onto a trailer or easily placed or relocated at point of use.

CAUTION

When traveling short distances (such as for rental situations within a city or local area) the bulbs may be left in place *IF* the transport vehicle (trailer or small truck) has a soft-riding suspension, preventing any sudden jars. For long-distance transportation, or in any instance when possibility of severe jarring, shock or excessive vibration exists, AND IN ALL INSTANCES OF

TRANSPORT VIA COMMON CARRIER, the bulbs *must* be removed from the lamphoods. The bulbs should be carefully packed in their original containers and transported vertically.

Damage to a xenon bulb during transportation, whether in place in a lamphood or separately packed, is not covered under warranty, nor is consequential damage.

4.0 BASE ASSEMBLY – ELECTRICAL COMPONENTS (see Figures 3 & 4)

To aid in understanding the function of each electrical component, the system is described below in the approximate order as related to the “flow” of electricity starting from the input power connection through the entire system of light and motion.

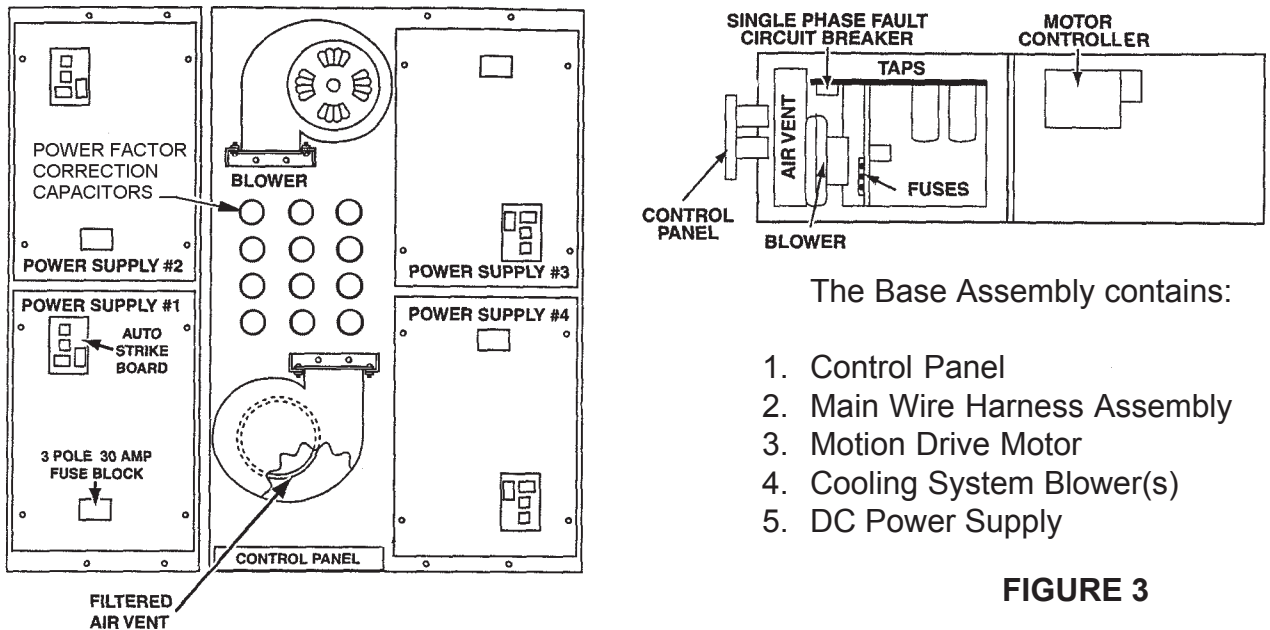

FIGURE 3

The base assembly electrical components which provide DC power for operation of the xenon light(s) are situated in modular group(s) and are identified by number as to which lamphouse they relate to.

Access to the electrical components for servicing can be accomplished by the removal of the side panels. The access panels can be removed by unscrewing the fasteners located along the outside edge of the panels.

4.1 CONTROL PANEL

The control panel (see Figures 1 & 2) is mounted in a recessed compartment or rain-tight box. Access to the control panel components is provided by the removal of four (4) corner screws and then swinging the panel forward and down. If desired, it may be removed by unplugging indexed plugs, which connect it to the individual power supplies and internal components.

The various input power cord receptacles, switches, circuit breakers, and hour meter are mounted to the panel and all electrical connections are accessible from the rear of the panel. Details of operation are covered in section 3.2.

4.2 MAIN WIRE HARNESS ASSEMBLY

The Wire Harness Assembly provides interconnection between the Control Panel and all electrical components within the base assembly. Each component may be individually disconnected for testing or removal for servicing, by unplugging the indexed connectors from the Wire Harness Assembly.

4.3 MOTION DRIVE MOTOR

The motion drive motor includes a gear-driven speed reduction unit, which operates on 220/240 volt 50/60 Hz. input and is activated by the "motion" switch located on the main control panel. STX-1 units are supplied with a variable speed motor controller.

4.4 COOLING SYSTEM

Blower(s) draw clean air through the bottom filtered inlet, pressurizing the base cabinet. The air then passes over the power supplies, cooling them, and continues through the flexible ducts to the lamphead(s). With the aid of supplemental blowers in the lampheads, the air continues through the base plenum, cooling the bulbs. Finally, the air exits out the bottom of the lamphead through screened outlets (see Figure 4).

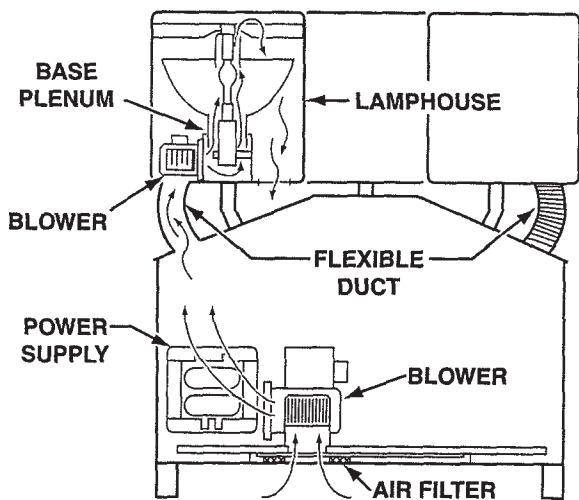

STX-4 COOLING SYSTEM

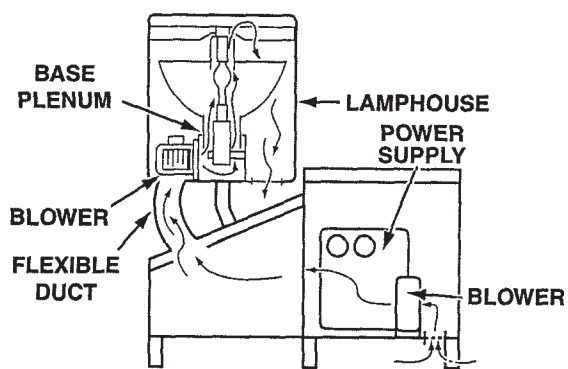

STX-1 COOLING SYSTEM

FIGURE 4

CAUTION

Each lamphead is protected from overheating by a Thermal Switch. DO NOT override this protection device as premature failure of the bulb may result. The Flexible Cooling ducts must be in good condition, securely mounted on both ends and with no visible holes in the duct's materials. The base cabinet should also be without holes and with all side panels in place to insure sufficient cooling to each lamphead.

4.5 DC (Direct Current) POWER SUPPLIES

The DC power supplies are modular units. They consist of large transformers that lower the input voltage down to a range of 25 to 45 volts to operate xenon bulbs. They also provide for a higher (125 to 150 volts) level required during the ignition phase. The output from the transformer is converted to the direct current (DC) required to operate xenon bulbs by silicon Power Diodes (see section 4.5.3). Additional power condition and filtering is provided by capacitors mounted inside the power supply modules.

4.5.1 POWER SUPPLY CONTACTORS

The Power Supply Contactors (mounted on the top of each power supply) serve as the main power switch to turn each power supply on and off. They are actuated when the "Master" switch on the main control panel is turned to the "ON" position and the individual "Lamp OFF" switch is in the "ON" position. However, if the lamphead thermal switch or power supply thermal switch is opened due to a "high temp" condition, the contactor for that particular head will not engage.

4.5.2 VOLTAGE ADJUSTMENT TERMINAL BOARD

The power supplies within each Sky-Tracker are provided with variable taps for adjusting the current delivered to each xenon bulb. This feature is helpful if the input voltage (from either regional power service or portable generator) is either higher or lower than "normal" rated input voltage of the Sky-Tracker.

The taps are set at the factory for optimum performance with normal input voltages (see section 3.1). For optimum Sky-Tracker performance consistent with long bulb life, the input should be measured while the Sky-Tracker is in operation. If the input voltages vary below or above the levels specified in section 3.1, the taps should be reset.

If input voltages are found to be lower than normal, a HIGHER tap setting will result in normal rated lamp intensity. If input voltages are found to be higher than normal, a LOWER tap setting will reduce the lamp intensity to normal levels and prolong bulb life.

<u>WATTAGE</u>	<u>CURRENT RANGE</u>	<u>NOMINAL</u>	<u>DO NOT EXCEED</u>
2000	50-90 A.	75 A.	90 A.
4000	90-150 A.	130 A.	150 A.
7000	100-160 A.	150 A.	160 A.

CAUTION

If input voltages (measured with the Sky-Tracker in full operation with all lights and motion on) are found to be BELOW the minimum levels specified in section 3.1, damage to components may result and in particular the motion motor may burn out. If voltages are found to be below the minimum levels, DO NOT OPERATE THE SKY-TRACKER. Components damaged from low voltage operation will NOT be replaced under warranty. Similarly, if any other components fail (including the xenon bulb) from over-voltage operation, they will NOT be replaced under warranty.

NOTE: In certain areas 208 volts AC (rather than 220/240 volts) is the “normal” input voltage. Although Sky-Trackers will operate on 208 volt input, the brightness and overall performance will be less than normal unless the input voltage adjustment taps are changed to compensate for this normal 10% reduction in input voltage. Also, in some instances where current draw of the Sky-Tracker is causing input circuit breakers to “trip,” or if portable generators are “lugging down” and causing them to deliver less than normal input voltage, a downward adjustment of the taps to lower the lamp output will sometimes cure the problem.

SINGLE PHASE ADJUSTMENT: 2kW (240V)

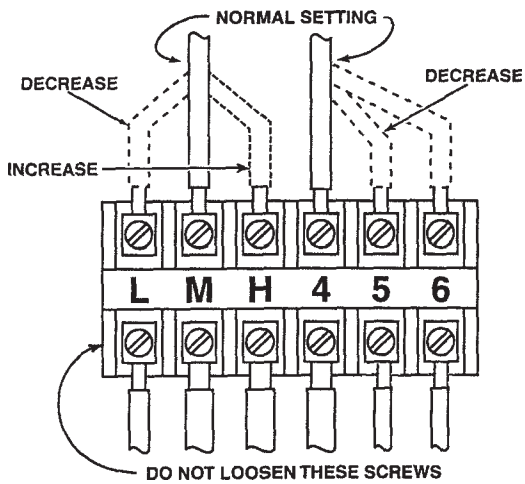

VOLTAGE ADJUSTMENT TAPS
(Single Phase)

FIGURE 5

A Voltage Adjustment Terminal Board is located on the top of each power supply and the various taps, or wire positions, are shown in Figure 5. The taps are identified as Low (L), Medium (M), High (H), 4, 5, and 6.

Changing the letter taps (L, M, H) has a smaller, “fine tuning” effect. Changing the number taps (4, 5, 6) has a greater effect. The highest setting (H-4) gives the highest lamp output. The lowest setting (L-6) gives the lowest lamp output.

THREE PHASE VOLTAGE ADJUSTMENTS: 2kW - 7kW (208-230 Volt 3-Phase)

Six Voltage Adjustment Terminal Boards are located on the side of each power supply. The various taps, or wire positions are shown in Figure 5. The taps are identified as “W, X, Y, Z” on the three (3) terminal boards, and “1, 2, 3, 4” on the remaining boards.

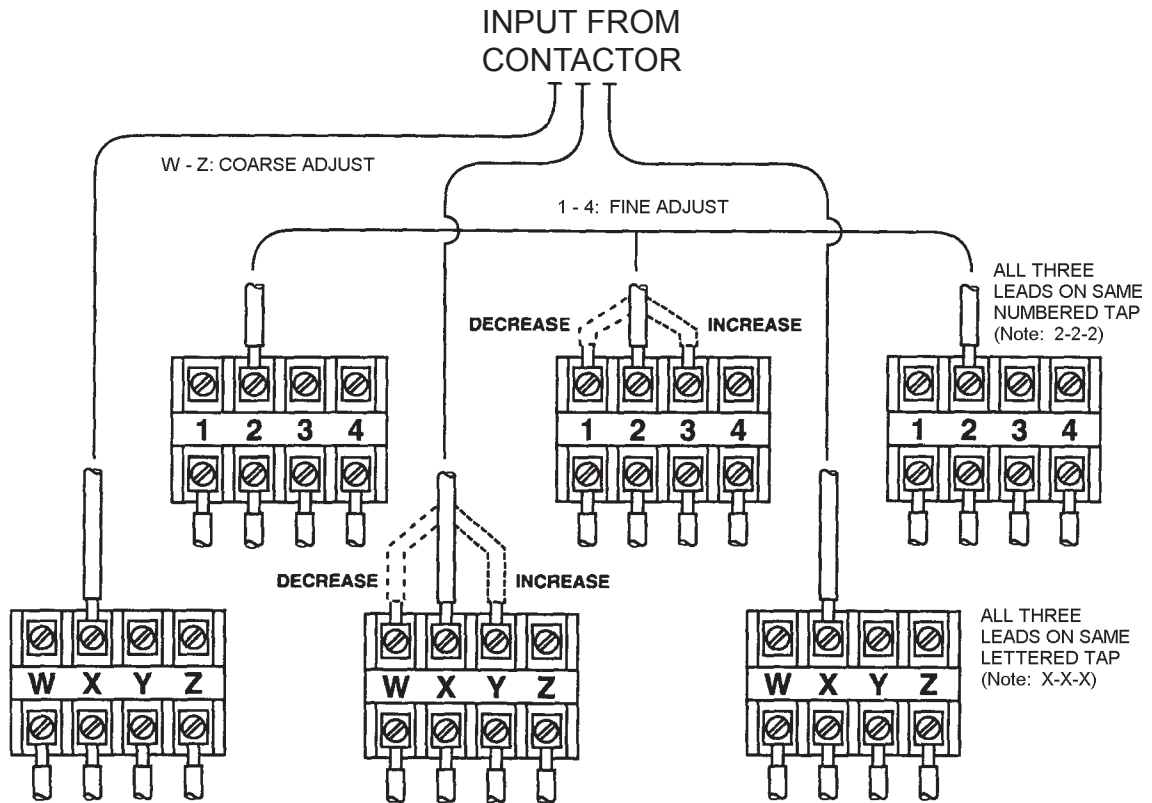

VOLTAGE ADJUSTMENT TAPS
(Three Phase)
FIGURE 6

Changing the letter taps (W, X, Y, Z) has a greater effect on voltage. Also, changing the number taps (1, 2, 3, 4) has a small “fine tuning” effect. The highest setting (Z-4) gives the highest lamp output and the lowest setting (W-1) gives the lowest lamp output. Taps on the (6) terminal boards MUST be changed in unison (i.e. three terminal boards set on #2 taps and three terminal boards set on “X” taps. See Figure 6).

4.5.3 POWER DIODES

Silicon diodes, located on large heat sinks, are attached to each power supply. The diodes convert the AC to DC, which is necessary for operation of the Xenon lamps. While diodes are very reliable, they sometimes fail due to voltage surges or “spikes” which sometimes occur, particularly with improperly regulated generators.

4.5.4 AUTO STRIKE ASSEMBLY – (STX-4 XENON LAMP AUTOMATIC IGNITION)

The Auto Strike Assembly is a module consisting of a printed circuit board and related components located near each power supply. Functionally, this circuit activates the igniter circuit when it senses that the light has been turned on, but the bulb is not drawing any current. It provides igniter bursts to the lamp and then locks itself out to prevent overloading and potential burn-out of the primary transformer. The auto strike can be re-activated by flipping the “Master” switch off and then back on again.

4.5.5 TIMER PBC ASSEMBLY

STX-1 units are supplied with a printed circuit board assembly that controls Auto Strike action as described above, and a 30 minute cool down timer for units operated by remote or unattended operation.

4.6 POWER FACTOR CORRECTION CAPACITORS

Xenon lamp power supplies have low power factor in conversion from AC to DC for lamp operation. Xenotech-Strong International has incorporated capacitor banks, which improve the efficiency factor, thus reducing power consumption and allowing operation at lower current levels. This in turn reduces input power requirements and the size and rating of input power cables and circuit breakers.

The power factor correction capacitors are mounted (in groups for each power supply) on the base between the power supplies. Each group is wired directly to its related power supply

4.7 DC POWER AND IGNITION CABLES

Three cables connect the DC power supply and the control system to each lamphouse. In each group the two large, single-conductor cables supply DC current to the lamps, while the center multiconductor cable supplies AC control voltage, igniter operation and fan power.

5.0 BASE ASSEMBLY, MECHANICAL COMPONENTS – STX-4 (5.1 to 5.5)

Components that are required to provide the unique motion of the Sky-Tracker STX-4 are contained within the base assembly.

5.1 MOTION DRIVE TRAIN

The motion drive train provides mounting for the four lamphouses by the motion spindle assemblies, which are timed together by one continuous timing belt. The number 3 motion spindle assembly (opposite the control panel) is driven by the reduction gear motor through a chain drive (see Figure 7).

CAUTION

DO NOT attempt to rotate the Sky-Tracker head assemblies by hand unless the chain has been disconnected, as damage may occur to the motion drive train.

5.2 MOTION ASSEMBLIES

The motion assemblies provide both for the oscillating motion of the Sky-Tracker and mounting support for the lamphouses. Each assembly consists of a “bent shaft,” shaft seal, drive/timing pulley and lower and upper bearing. Bearings in the housing assemblies are permanently lubricated and do not require regular maintenance.

5.3 TIMING BELT IDLERS

The timing belt idlers serve to center the timing belt onto the spindle drive pulleys. The timing belt should not ride on the sides of the drive pulleys, as this condition will cause extraordinary wear to the timing belt. The idlers have been adjusted at the factory and usually do not need re-adjustment.

5.4 TIMING BELT TENSIONING ADJUSTMENTS

Timing belt tensioning is accomplished by two turnbuckles mounted on motion assemblies #2 and #4 which are located to the left and the right of the control panel. To tighten the timing belt, loosen (but do not remove) the four mounting bolts that hold the lower bearing mount to the base and tighten the two turnbuckles equally. The belt tension should be such that its deflection from a straight line (between points of contact with the drive/timing pulley and idler) is between 1/8" and 1/4" (3-7 mm) when a force of 50 lb. (22.6 kg) is applied midway between the drive pulley and idler.

After achieving proper belt tension, the turnbuckle lock nuts and the four mounting bolts on each side must be securely re-tightened.

CAUTION

Tightening the timing belt from one side only may alter the synchronization of the four lamphouses, causing them to bang together in the "up" position.

Proper timing belt tensioning is important. A loose belt may cause the heads to slip out of synchronization, causing them to hit each other. An overly tight belt can cause tearing of the reinforcing cords within the belt, leading to premature belt failure.

5.5 SPRING ASSEMBLIES

Each spring assembly consists of pairs of springs that counter balance the lamphouses. The Sky-Tracker should not be operated with a broken spring for prolonged periods of time, as this will cause extraordinary wear on the drive system that may result in failure. A broken spring may be replaced by removing the bolt and related spacers on the end of the spring mounting shaft.

CAUTION

Springs should be replaced with lamphouses in an upright position, reducing the tension on the springs.

NOTE: The springs have special screw-on ends with ball joint connectors. When replacing a spring, the rod end and cap must be removed from the broken spring and re-installed on the new spring (includes retaining plugs). After re-assembly and alignment, the lock nuts must be tightened to prevent accidental disassembly.

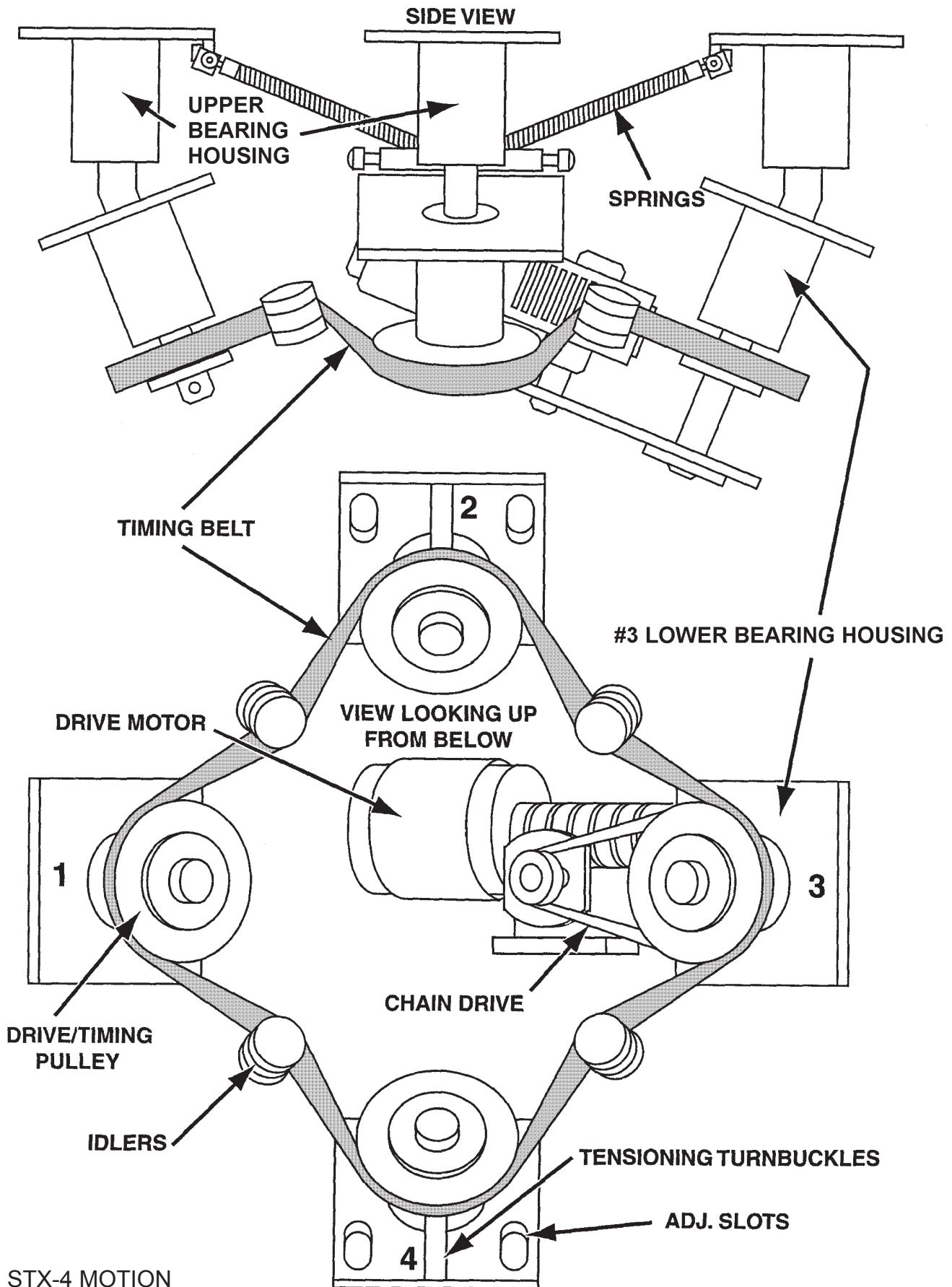

STX-4 MOTION
DRIVE SYSTEM
FIGURE 7

5.6 BASE ASSEMBLY – MECHANICAL COMPONENTS - STX-1 (5.6 to 5.9)

Components that are required to provide the unique motion of the Sky-Tracker STX-1 are contained within the base assembly.

5.7 MOTION DRIVE TRAIN

The motion drive train provides mounting for the lamphouse by the motion assembly. The assembly is driven by the reduction gear master by a chain drive (see Figure 7a).

CAUTION

Do not attempt to rotate the Sky-Tracker head assembly by hand unless the chain drive has been disconnected, as damage may occur.

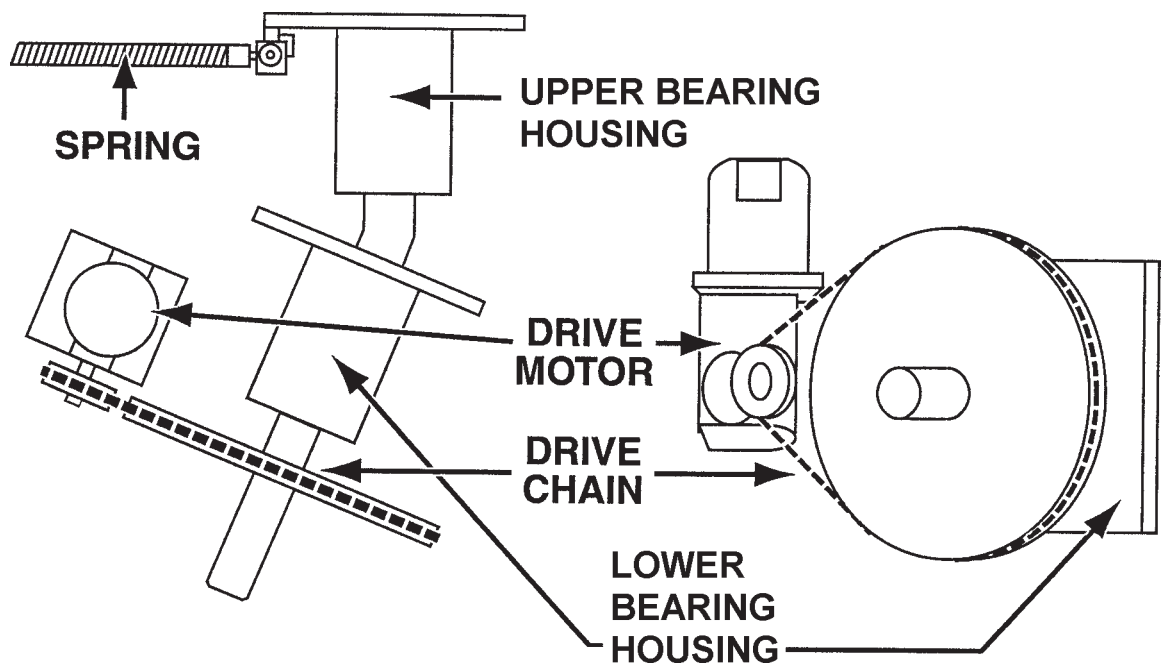

STX-1 CHAIN DRIVE SYSTEM
FIGURE 7a

5.8 MOTION ASSEMBLY

The motion assembly provides for both the oscillating motion of the Sky-Tracker and mounting support for the lamphouse. The assembly consists of a “bent shaft”, shaft seal, drive pulley, and lower & upper bearings. Bearings within the assembly are permanently lubricated and do not require regular maintenance.

5.9 DRIVE CHAIN TENSION ADJUSTMENT

The drive chain may loose tension over time and need adjustment. To adjust the drive tension, loosen the four bolts holding the gear reduction motor to the system frame, DO NOT remove. Apply pressure to the motor until deflection of the chain is less than $\frac{1}{4}$ " (6mm) when force is applied midway between the drive pulley and the motor pulley. After achieving proper tension, tighten the four motor mounting bolts.

6.0 LAMPHOUSE ELECTRICAL COMPONENTS (2 & 4 kW Models)

All high voltage igniter components, cooling blower(s), thermal switch, and DC power connectors to the xenon bulb are located in the lamphouse (see Figures 8 & 9). The functions of the various components are as follows:

6.1 IGNITER SYSTEM

The complete high voltage igniter circuitry is located on the lamphouse base plate. To gain access to the internal electrical components, it is only necessary to unlatch the two draw-down latches located at the bottom of the housing. Then, slide the fiberglass housing upward and away from the tubular frame assembly. With the components exposed, the following items that make up the igniter system can be accessed.

See PARTS LIST, Figure 2, for 7 kW unit.

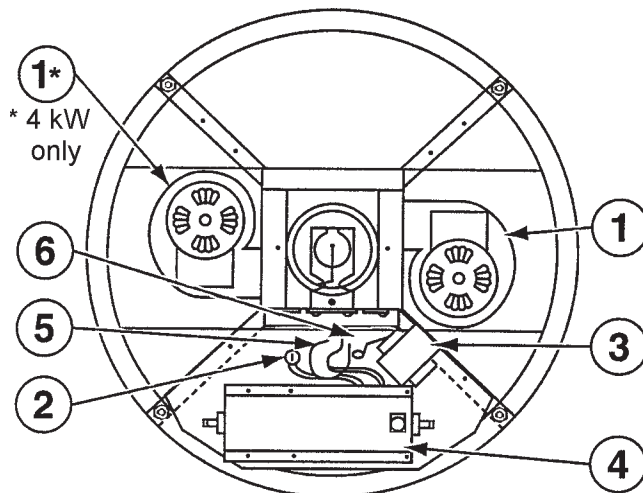

1. Blower(s)
2. Spark Gap
3. Primary Transformer
4. R.F. Igniter Transformer
5. Doorknob Capacitor
6. R.F. Trap

LAMPHOUSE BASE PLATE
ELECTRICAL COMPONENTS
FIGURE 8

DANGER

Before opening the lamphouse, disconnect all input power to the Sky-Tracker so that the igniter cannot be accidentally operated. Severe electrical shock can result if the igniter is accidentally operated when these parts are exposed.

6.1.1 PRIMARY TRANSFORMER

The Primary Transformer receives an input pulse when either the autostrike assembly or the manual start button is actuated, and raises this voltage to approximately 6,000 V.AC, 50/60 Hz. If replacement is required, it may be easily removed by unplugging the two (2) pin input connector, disconnecting the single output wire from the capacitor and removing the two (2) screws which hold it to the right hand Plenum Support Bracket.

CAUTION

This transformer is wound with a large number of very fine windings and is subject to “burn-out” if, for any reason, the input power is supplied for longer than two seconds.

6.1.2 R.F. “IGNITER” TRANSFORMER

The R.F. (Radio Frequency) Igniter Transformer is specially constructed transformer that provides an ignition pulse of 40,000 volts when the output of the Primary Transformer is fed through its primary winding to a grounded spark gap. The negative (-) DC power from the power supply is fed through the secondary winding of the R.F. transformer to the lower (or cathode) end of the xenon bulb.

6.1.3 SPARK GAP AND RELATED COMPONENTS

Other components of the Igniter System include a spark gap, a “door knob” capacitor, and various smaller capacitors and “R.F. Traps”. Figure 8 indicates the location of these components.

6.2 D.C. POWER CABLES

The flexible cables that carry the DC power from the Base Assembly to the lamphead enter through the baseplate. The positive (+) input cable is attached at an interconnect point to a similar cable within the lamphead connected to the upper bulb support spider. The spider in turn carries the DC positive (+) power through jumper cables then to the upper bulb adapter which is attached to the front or anode (+) end of the xenon bulb.

The negative (-) DC input cable is attached directly to one end of the R.F. transformer. A short, flexible cable then connects the other end of the R.F. transformer to the end of the bulb, which is the cathode (-) end of the xenon bulb. This cable and all components between the output side of the R.F. transformer and the xenon bulb must be well insulated and maintained at least one inch from any “ground” or conductive components of the lamphead, in order to prevent shorting and/or loss of ignition energy to the bulb.

6.3 COOLING BLOWERS

One or two cooling blowers, depending on the lamphead model, are attached to a square plenum, which distributes air to the lamp and rear of the reflector and also provides support for the base (cathode end) of the lamp. A third blower, mounted below the base plate, is required for 7 kW operation. Access to this plenum and the base end of the bulb is achieved through removal of four screws securing a cover plate to one side of the plenum.

6.4 THERMAL SWITCH

Each lamphead is equipped with a Thermal Switch that will detect “High Temperature” conditions. The switch is located on the upper bulb support spider (see Figure 9, Item 7). When the temperature in a lamphead reaches a level that may be harmful to the system, the Thermal Switch will open – turning that particular lamp off.

6.5 XENON BULB (LIGHT SOURCE)

The light source is supplied through the use of a high quality xenon bulb (see Figure 9). The bulb is securely attached to the circuit to minimize mechanical and thermal stresses. Instructions to install and remove the bulb are detailed in sections 8.0 and 9.0.

7.0 LAMPHEAD MECHANICAL COMPONENTS

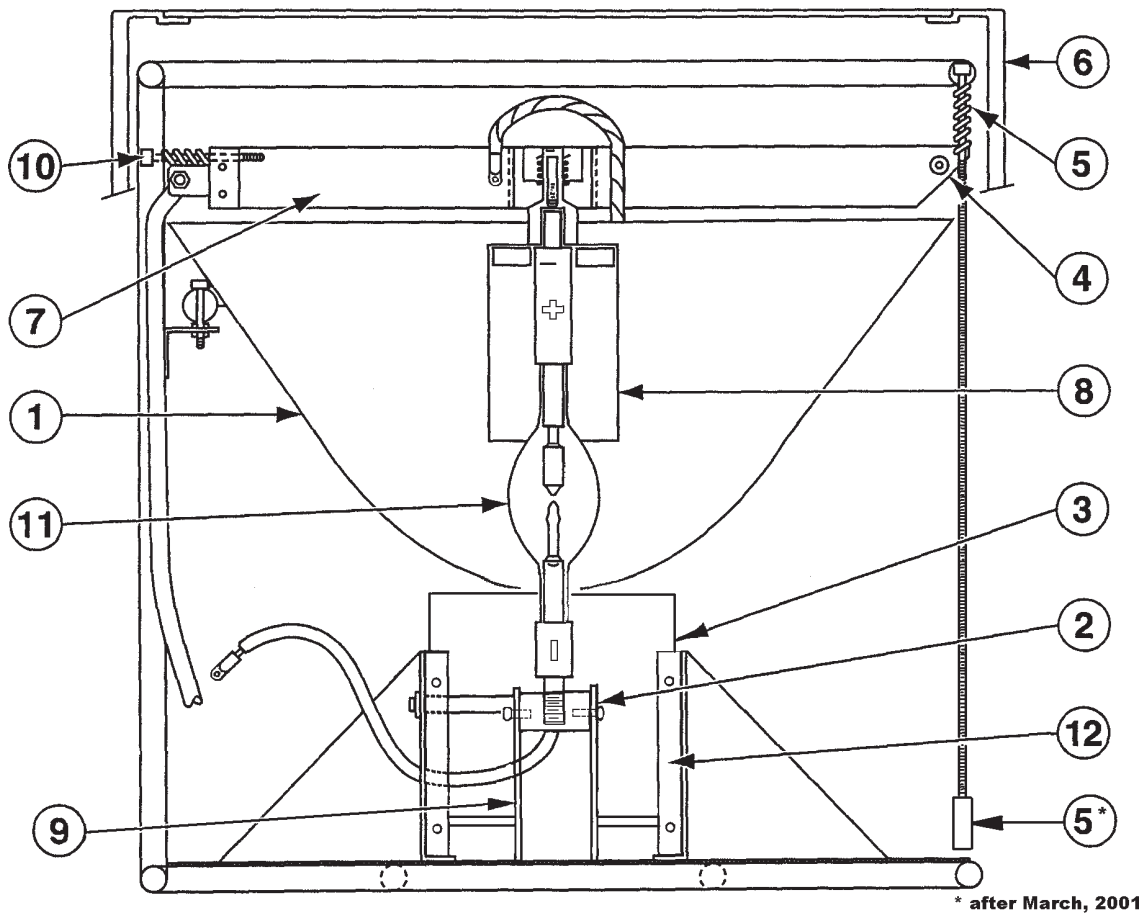

FIGURE 9

- | | |
|------------------------------|---|
| 1. Reflector Assembly | 7. Anode Support Spider |
| 2. Cathode Pin Receiver | 8. Anode Adapter |
| 3. Air Plenum | 9. Lower Lamp Support |
| 4. Thermal Switch | 10. Bulb Centering Adjustment “X” and “Y” |
| 5. Bulb Focus Adjustment “Z” | 11. Xenon Bulb |
| 6. Housing Assembly | 12. Insulator Cover Plate (removed for clarity) |

The xenon lamphead has been designed and constructed for ease of operation and serviceability in extreme weather conditions and operates satisfactorily in rain or snow. In operation, the lamphead is slightly pressurized as a result of the cooling air inflow, thus aiding in the exclusion of dust or moisture. The basic components are shown in Figure 9.

The two primary components of the lamphead are the deep dish electroformed parabolic reflector and the xenon bulb (light source). To function efficiently, these components must be mounted in such a manner that the bulb can be carefully positioned with its radiant energy source precisely located at the focal point of the reflector. The bulb must be capable of adjustment as to its relationship with the reflector to optimize the projected beam characteristics. All electrical connections to the bulb must be of low resistance and capable of carrying relatively high currents (50 to approximately 160 Amps.) and cooling must be constant and effective to maximize bulb life and minimize electrical conductivity problems that can result from overheating. The components, which accomplish these functions, are noted below.

7.1 REFLECTOR ASSEMBLY

The electroformed parabolic reflector is precision bonded to a circular support ring, which in turn bolts to the lamphouse tubular frame. If replacement is required, first, remove the lamp as noted in section 9.0. Next, detach the upper support spider and associated components. Finally, unbolt the reflector from the lamphouse tubular frame.

7.2 CATHODE SUPPORT

The rear, or cathode (-) end of the xenon bulb is supported by slotted bulb guides, which are bolted to the bottom of the air plenum. This allows the bulb to move freely in the vertical axis for beam adjustment and to eliminate strain on the quartz envelope of the bulb.

7.3 AIR PLENUM/DUCT

The air plenum is attached to the base center support baffle and provides a means of ducting and directing the airflow around and over the xenon bulb to the front, or anode (+) end of the bulb.

NOTE: It is crucial that heat be properly removed from the anode end of the bulb to avoid damage to its internal seal.

7.4 ANODE ADAPTER

The upper bulb adapter, which is a tubular section surrounding the front portion of the bulb and attaches to the anode (+) end of the bulb, serves a dual purpose. The point of attachment to the bulb and also provides a means of removing heat from the bulb by direct conduction. As the heat is conducted outward from the bulb into the front bulb adapter, it spreads outward into the tubular section of the adapter by conduction. It is then removed by convection to the air stream, which has been directed over the bulb by the air duct.

7.5 ANODE SUPPORT – SPIDER AND ADJUSTMENT ASSEMBLY

The upper bulb support also serves a dual purpose. Its construction of highly conductive aluminum permits DC power to be carried from the input cable to the anode end of the bulb with very little loss due to electrical resistance. Additionally, it provides a pivot point, which allows the xenon bulb to be adjusted in the X or Y axis without developing any undesirable bending forces that could stress the quartz envelope of the xenon bulb. Movement of the bulb along the Z axis during focusing is also readily accomplished by the pivoting motion of the upper bulb support.

7.6 HOUSING ASSEMBLY

The housing assembly provides a front closure to the lamphood. A tempered glass window is attached to the housing by means of silicone rubber sealant to provide a watertight seal. The tempered glass window is not affected by temperature shock, (such as rain or snow suddenly applied to the window) even when it is operating at normal temperatures. The high-strength tempered glass also resists accidental breakage resulting from foreign objects.

8.0 BULB INSTALLATION

Upon original delivery or subsequent common carrier transportation of the Sky-Tracker, the customer will be required to install the xenon bulb into the lamphoods. The procedure is as follows:

DANGER

The handling of a xenon bulb may expose the operator or technician to hazards resulting from bursting of the quartz envelope, because of the high internal pressure of the xenon gas.

Bursting may occur if the bulb is dropped or mishandled. The hazard is substantially increased if the lamp is hot from operation, as the gas pressure increases in a manner directly proportional to the increased temperature. Whenever the xenon bulb is removed from its protective cover, and until the installation or removal is complete and the lamphouse window assembly is secured, the operator or technician **MUST** wear protective clothing, including Kelvar™ gloves, acetate face shield, and quilted ballistic nylon jacket or equivalent. (These items are available from Xenotech-Strong International.) Instructions regarding protective clothing are subject to change by any local or federal agency that may have authority over such matters, dependent on area or point of use of the Sky-Tracker equipment.

It should be noted that xenon bulbs do not “explode” in the normal sense, in that there is no combustible energy-releasing reaction occurring. They merely “burst” like a balloon or a pressure vessel. The hazard is related to the flying particles of glass-like quartz, which are propelled with sufficient force to penetrate normal clothing, eyes, and skin. It can not be over-emphasized that protective clothing, gloves, and eye protection be worn when handling xenon bulbs.

BULB INSTALLATION STEPS

1. Place the lamphood in the upright vertical position.
2. Remove the housing and set aside.
3. Remove the two bolts that secure the power jumper cables to the upper bulb adapter. Remove the central bolt/washer and spring assembly that secures the front bulb adapter to the anode support "spider".
4. Inspect reflector for cleanliness; clean if necessary.
5. Carefully remove xenon bulb from shipping container and remove protective cover. (Save the container and packing for future shipping purposes.) Use caution to handle the bulb only from the metal end fixtures, not allowing finger contact with the quartz envelope. Finger oils or other foreign material on the quartz envelope can lead to rapid, premature failure. If accidentally touched and contaminated, carefully clean the quartz envelope with tissue moistened with alcohol and then wipe dry with a clean, dry, lint-free tissue.
6. Inspect the upper bulb adapter and end pins of the lamp to make sure that these contact areas are clean and free of corrosion or any contaminant which could cause a high resistance electrical joint. Make sure that the clamp screws on the upper bulb adapter are loosened and that the upper bulb adapter will slide freely over the front anode (+) end of the bulb.
7. After sliding the top bulb adapter onto the anode (+) end of the bulb, carefully turn the two components upside down and hold the adapter with the bulb vertically. Then, while tighten the clamp screws. This will insure that no bending force is applied to the bulb body, which could cause an accidental and dangerous bursting if stressed. Tighten the screws carefully, a little at a time, alternating back and forth between each clamp screw until they are completely tight, alternating back and forth between each clamp screw until they are completely tight and no further screw rotation is possible using moderate force. Carefully check to be sure that the bulb end is not loose within the top bulb adapter clamp.
8. Hold the bulb and upper bulb adapter subassembly carefully by the adapter (continue using caution not to touch or contaminate the quartz lamp envelope). Lower the lamp carefully through the hole in the center of the reflector, using caution not to nick or damage the reflector or bump any portion of the bulb. Carefully insert the cathode end

BULB INSTALLATION STEPS (continued)

of the bulb into the lower bulb receiver. Rotate the bulb so that all three leads of the threaded bulb ferrule start. Tighten until the spring pins of the receiver engage the bulb. Apply one-quarter turn to the bulb. Do not overtighten the bulb. Insert the upper bulb adapter pivot bolt/washer/spring assembly into the center of the “spider” and engage the bolt a few turns into the upper bulb adapter.

NOTE: If space appears inadequate to accomplish this joining of the spherical pivot points, more space can be provided by adjusting the Z focus screw in a clockwise direction, which moves the spider away from the reflector.

9. The top adapter may have to be carefully rotated, so that the two tapped holes on the adapter are symmetrically located with respect to the two spider legs, which are located at a right angle (90 degrees apart). Loosen the two clamp screw if required. This is necessary so that the front power jumper cables can be properly attached. When this positioning has been achieved, the upper bulb adapter attachment bolt/spring assembly may be tightened. *The shoulder bolt should be tightened until it bottoms.* The clamp screws should be tightened if necessary.
10. The front power jumper cables, which conduct power from the spider to the upper bulb adapter, can now be attached. Make sure that the cables are properly positioned within the protected area of the upper bulb adapter, so that they do not protrude into the light beam (which will cause some loss of light and overheating of the cables). Make sure all connections are tight.
11. Carefully replace the fiberglass lamphead cover assembly. Make certain that the adjustment holes in the housing align to the frame. Make sure that the window is clean, both inside and out.

The lamphouse is now ready for operation, pending final focusing and adjustment during nighttime conditions.

8.1 FINAL FOCUS AND BEAM ALIGNMENT

Final focusing and beam alignment can only be properly accomplished outdoors during nighttime operation.

After the lamphouse has been placed into operation and allowed to warm up for approximately five minutes, the beams can be adjusted and aligned as follows:

LAMP FOCUS PROCEDURE

1. Operate the motion until the lampheads swing *outward* and shut off the motion with the lampheads extended in the outermost position. This provides easier access to the focus adjustments.

The two bulb centering movements (normally described as X and Y adjustments, see Figure 9) are located in the sides of the lamphead. They are approximately three inches down from the top, or window end, of the lamphead and immediately adjacent to the ends of the two spider legs, which are located at right angles to each other (90 degrees apart). The adjustment holes are closed with plugs to prevent entrance of moisture and dirt. Carefully remove the plugs and insert the appropriate adjustment tool (5/32" allen wrench).

2. With the light operating, the operator should position himself adjacent to either one of the X or Y adjustments so that he can view the beam from that angle, while adjusting the other adjustment. In other words, if he positions himself adjacent to the X adjustment and views the beam from that position, he will be able to visually assess the results of his adjustment of the Y adjustment. The operator should alternately turn the opposite adjustment first clockwise and then counterclockwise to observe the movements of the apparent center of the beam and try to obtain symmetry.

The operator should then move and reposition his body adjacent to the other adjustment, 90 degrees removed, and then adjust the other beam centering adjustment. The combination of movements of these X and Y adjustments should result in a completely symmetrical beam shape when viewed from any position.

3. Focus adjustment (see Figure 9): The focus adjustment is performed on the third leg of the spider assembly and is accessible by removal of the plug located on the front rim of the fiberglass housing assembly adjacent to the window. On units manufactured after March 2001, the adjustment screw is accessible from the bottom of the lamphead (Figure 9, Item 5*). Clockwise rotation of this adjustment will move the bulb forward, or away from the reflector, causing the beam to converge to a narrower appearing beam. Counterclockwise will cause the bulb to be moved deeper into the reflector, causing a divergence or spread of the beam. The operator will have to judge which type of beam is most suitable for the intended application or use.
4. After adjustment is complete, be sure to replace all plugs to prevent entrance of undesirable moisture and dirt into the lamphousing.

Since all of the above noted adjustments are spring loaded, there should be little or no free movement or "backlash," nor drifting of the adjustments due to vibration associated with transport. The bulb should remain reasonably well focused for long periods of time. However, as the bulb ages, the cathode tip will burn back and the quartz envelope will darken, and some minor refocusing may be required to maximize performance and appearance.

9.0 BULB REMOVAL

DANGER

Wear all required protective clothing and follow prescribed steps carefully.

1. If the xenon bulb has been in operation, wait *at least* 15 minutes after Lamp shutdown (with blowers operating), before opening the lamphead. This will allow the internal lamp pressure to reduce to a level that is permissible for handling, provided that the specified protective clothing is worn.
2. Reverse the steps of the Lamp Installation Procedure in section 8.0.

10.0 ROUTINE SERVICE AND MAINTENANCE

1.1 PERIODIC MAINTENANCE

Except for unusual conditions of use (dirty environment, flooding, non-passive bulb failure, etc.) the frequency of service and replacement of certain parts and components because of normal wear is directly related to hours of use.

Inspection and preventive maintenance should be performed approximately every 250 hours of use or every 3 months (whichever occurs first). The period can be adjusted according to actual circumstances. The following items are to be included at the time of each periodic servicing:

10.1.1 BASE

1. Remove and replace the intake air filter.
2. Inspect and tighten timing belt, idlers, pulleys and sprockets.
3. Inspect and lube the drive motor and chain.
4. Remove, lubricate, and reinstall blower motors.
5. Inspect and tighten, as required, all electrical connections.
6. Tighten all mounting bolts.
7. Inspect all of the flexible cooling ducts.

10.1.2 XENON LAMPHEAD ASSEMBLIES

NOTE: See Section 8.0 for safe handling instructions of xenon bulbs.

1. Remove lamphousings and the xenon bulbs (Section 9.0).
2. Inspect and tighten all electrical connections.
3. Inspect all focus mechanisms. Lubricate focus screws.

4. Clean reflectors and windows.
5. Clean bulb ends. Clean inside contact area of Upper Bulb Adapters, clean contact points on upper bulb support spider.
6. Tighten DC cables.
7. Inspect blower motors for proper air flow; clean impellers.
8. Reinstall bulbs and replace housings.

Operate the system – Check automatic ignition, thermal switch operation, motion (timing belt and motor) function and pilot lights.

NOTE: The main drive belt should not ride on the side of pulleys.

Operate and align lampheads; night-test and refocus all the bulbs.

Any parts (such as main drive belts, flexible air ducts, switches, etc.) which are found to be worn or in questionable condition, should be replaced to insure trouble-free operation. Xenon bulbs should also be replaced as required.

CAUTION

Upon expiration of the bulb warranty (see warranty information packaged with bulb), the possibility of the bulb bursting increases, particularly if the quartz envelope shows signs of excessive darkening.

If bursting occurs, the tempered window may also break and the reflector may become scratched, resulting in a degradation of the lamphead's performance.

For this reason, it is recommended that the Xenon bulbs be replaced once the specified warranted life span has been reached.

TROUBLESHOOTING GUIDE

<u>PROBLEM</u>	<u>PROBABLE CAUSE</u>	<u>WHAT TO CHECK</u>
NO MOTION DRIVE	Motor circuit is blown.	Inspect circuit breaker or reset breaker.
	Timing belt or chain is broken.	Lampheads will move by hand.
	Drive motor has failed.	Test for 220 V.AC at Motor Connector.
	Main Power lost.	
LAMPHEADS COLLIDE	Timing Belt has slipped.	Loosen #2 and #4 mounts and Turnbuckles and Re-time.
	Gear Belt Pulley has slipped.	Loosen Hub and Re-time Bent Shafts.
	Turnbuckles are not evenly adjusted.	Loosen #2 and #4 mounts and re-adjust Turnbuckles.
ONE LAMP IS OUT	Auto Strike is non-operational.	Try manual "Ignite" switch.
	Igniter Circuit is out.	Try manual "Ignite" and listen for arcing sound.
	Bulb has failed.	Inspect bulb for damage.
	A.C. Input power is out or A.C. power cord is out.	Check indicator light on panel.
	Cooling Blower(s) in the lamphead is out, causing the Thermal Switch to open.	Check Aux. circuit breaker.
	Power Supply is out.	Check Aux. circuit breaker. Also check D.C. output (should be 125/165 V.DC prior to ignition).
ALL (4) LAMPS ARE OUT	All blowers are out, causing Thermal switches to open.	Check Aux. circuit breakers.
	All (4) bulbs have failed (or are broken).	Check bulbs.
	Main Base Blower switch is not activating.	Check Main Blower. Check Blower Switch.

WIRING SCHEMATICS

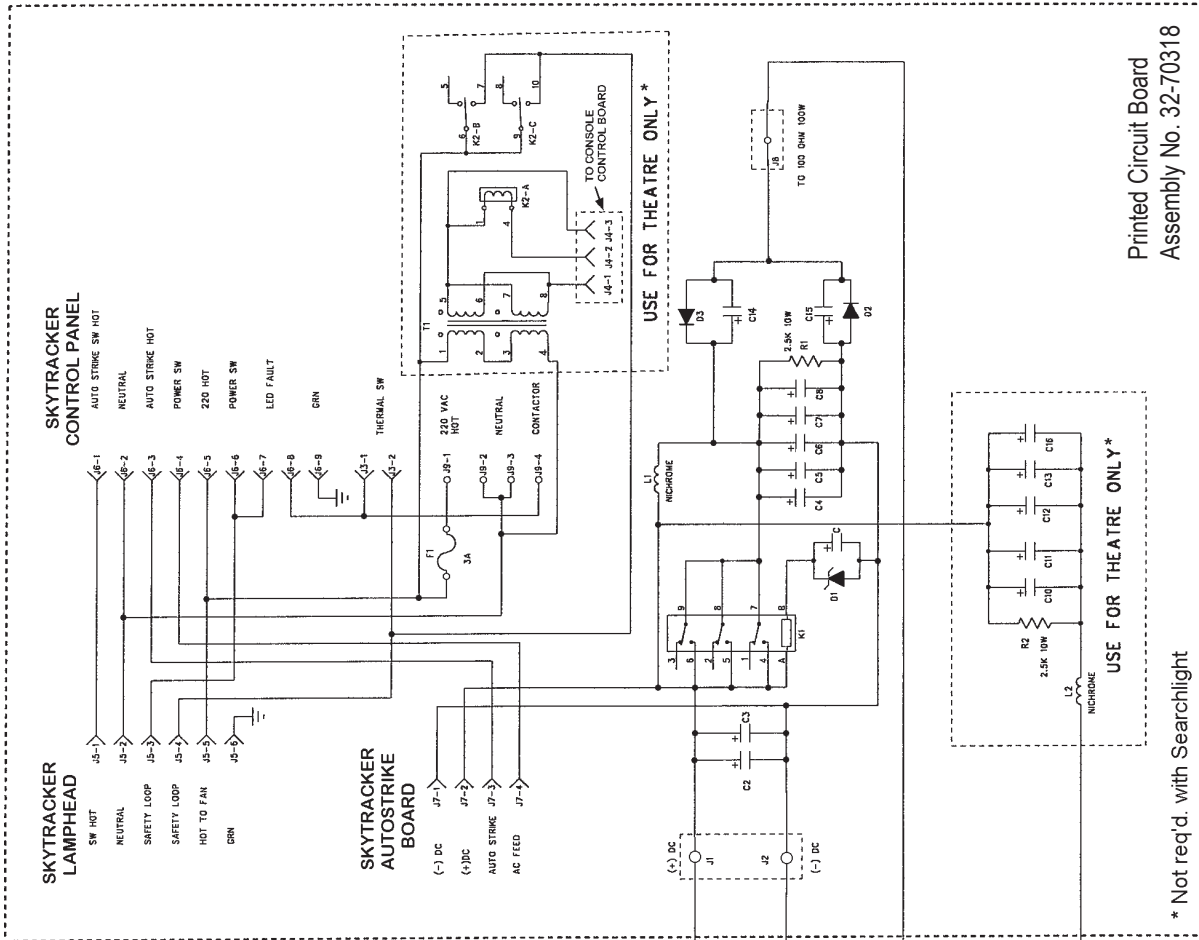

Printed Circuit Board
Assembly No. 32-70318

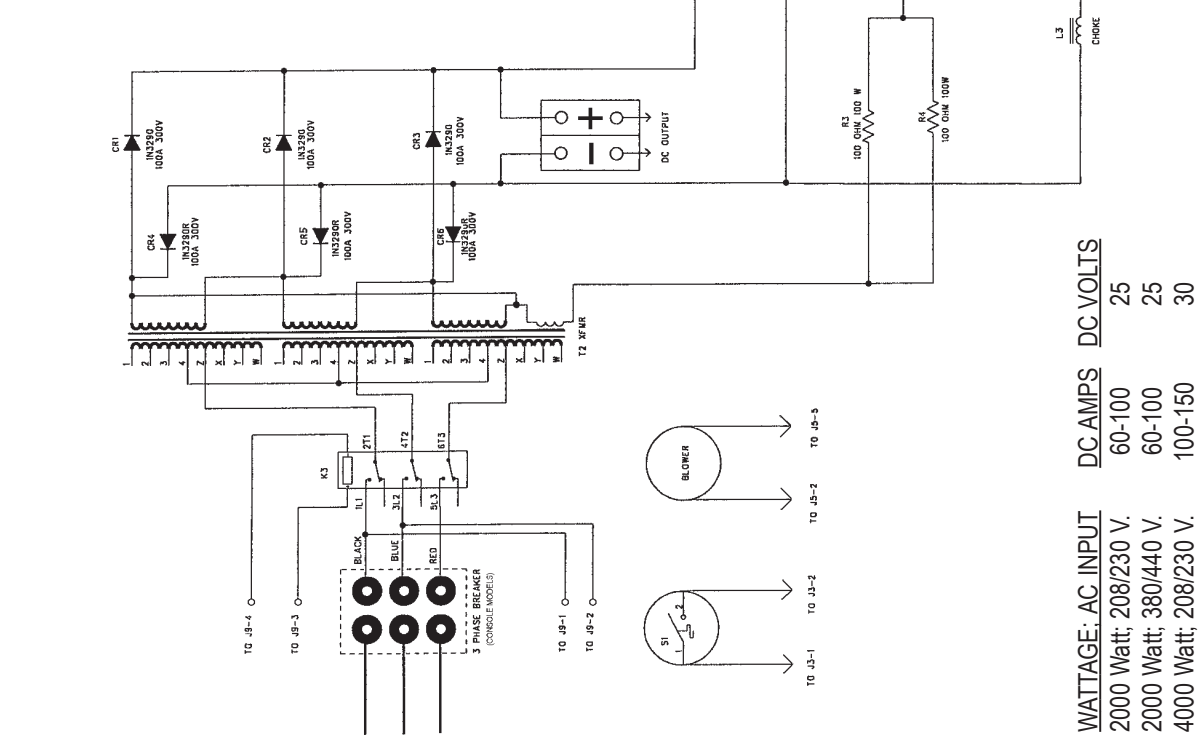

WATTAGE: AC INPUT	DC AMPS	DC VOLTS
2000 Watt; 208/230 V.	60-100	25
2000 Watt; 380/440 V.	60-100	25
4000 Watt; 208/230 V.	100-150	30
4000 Watt; 380/440 V.	100-150	30
7000 Watt; 208/230 V.	130-180	40
7000 Watt; 380/440 V.	130-150	40

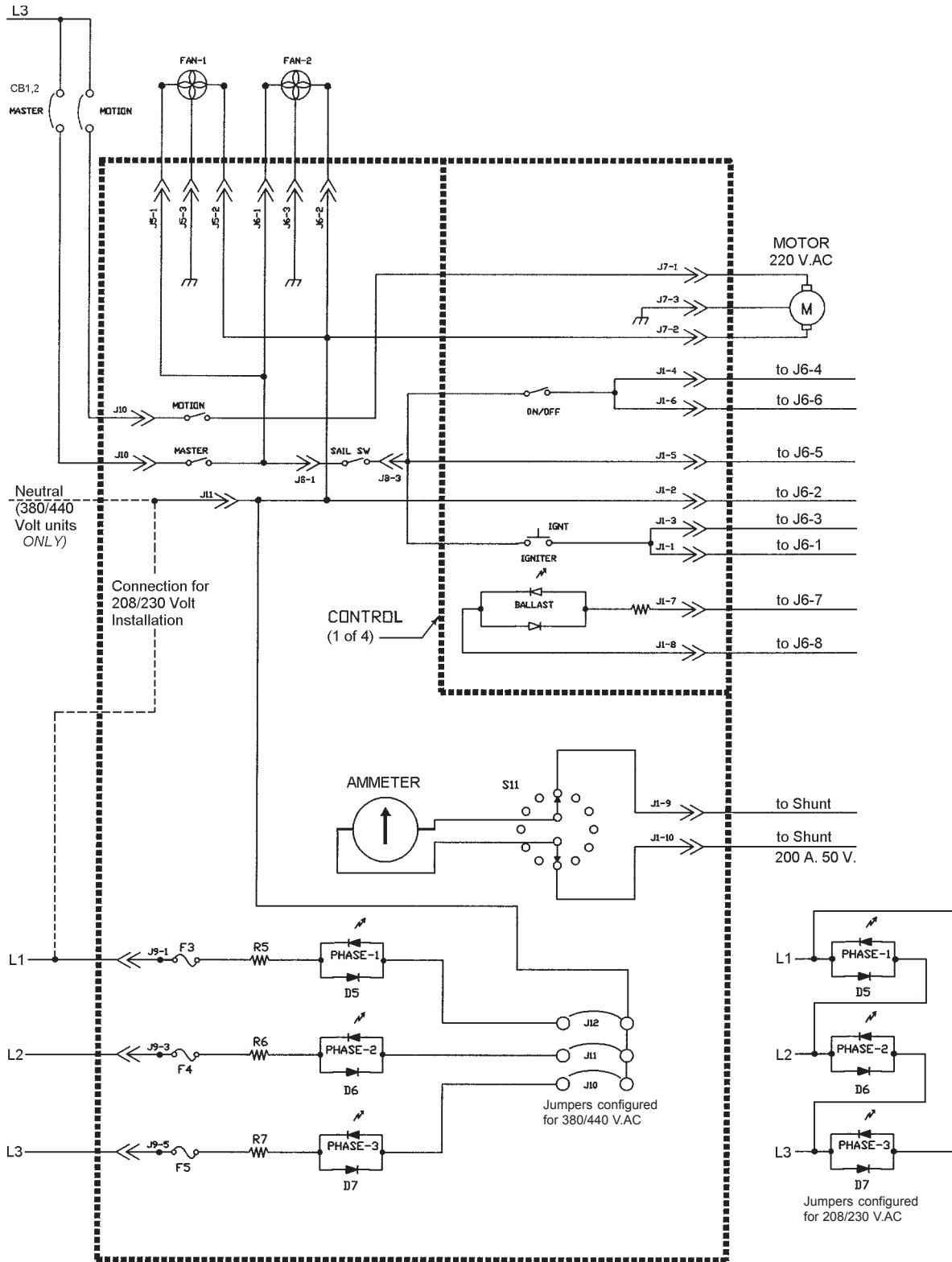

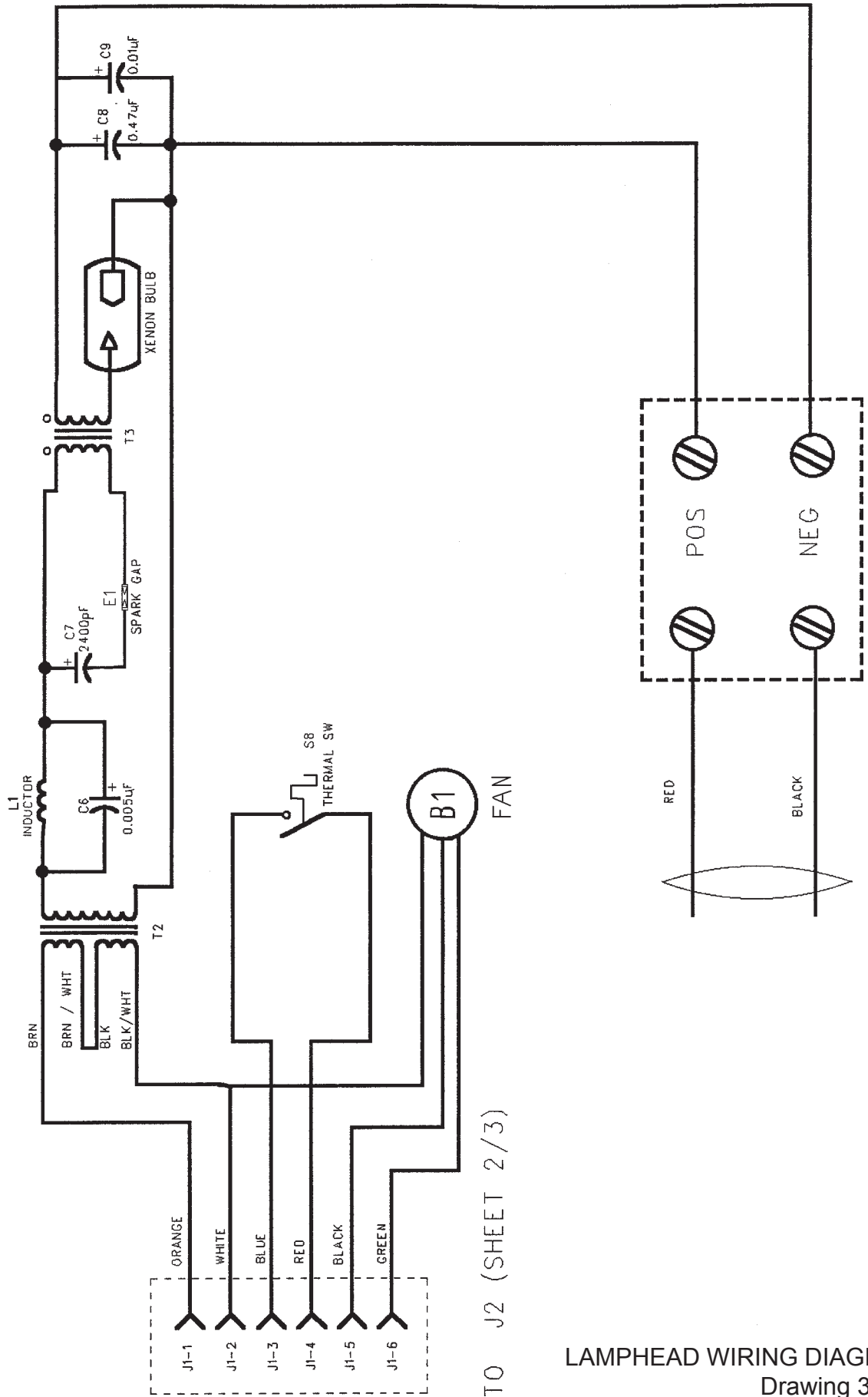

TO J2 (SHEET 2/3)

LAMPHEAD WIRING DIAGRAM
Drawing 3 of 3

Xenotech-Strong International

EQUIPMENT WARRANTY

Xenotech-Strong International agrees that its products shall be free from defects in materials and workmanship for a period of one year, from the date of original shipment from its factory. This warranty is nontransferable and applies to the original purchaser only. Said warranty will not apply if equipment is used in conditions of service for which it is not specifically intended. The manufacturer is not responsible for damage to its apparatus through improper installation, physical damage or poor operating practice.

If any device is found to be defective under the warranty, the buyer should notify the manufacturer. Such equipment will be repaired or replaced, at manufacturer's option, free of all charge except transportation, F. O. B. its factory. Any such repair or replacement by the manufacturer shall constitute fulfillment of all obligations to the purchaser. This warranty does not include troubleshooting expense, labor charges associated with service calls, and disassembly or reassembly of the lamp system. Should such a repair or replacement require an on-site service call, the Purchaser shall bear the responsibility for all costs and associated expenses. The manufacturer does not assume responsibility for any unauthorized repairs to its products, even though defective, and unauthorized parts or repairs shall void this warranty.

This warranty is the only warranty given with the manufacturer's products. There are no warranties of merchantability of fitness for a particular purpose or other warranties or representations of any kind, express or implied, which are made with respect to these products.

The remedies of the Owner set forth in this warranty are exclusive. In no event shall the buyer be entitled to recover for incidental, special or consequential damages, arising from the sale or use of these products, including but not limited to loss of profits or revenue, other commercial losses, inconvenience, delay, labor, repairs, or other cost of rental or replacement equipment.

This warranty excludes any and all incidental damage that may be caused by xenon bulb explosions. The bulbs used in manufacturer's products are not included in this warranty, however, they are covered by the bulb manufacturer's warranty.

LAMP POLICY

1. To avoid unnecessary down time because of bulb failure, it is suggested that all owners keep at least one spare bulb, of each type required, on hand.
2. To return a bulb, the owner must first obtain a Returned Materials Authorization Number (RMA) from Xenotech-Strong International's Repair/Service Department in North Hollywood, California.
3. All returned bulbs must be accompanied by the manufacturer's warranty form, properly completed, and must be shipped in the original manufacturer's shipping container with proper cushioning inserts.
4. It is not Xenotech-Strong International's policy to supply "replacement bulbs" for bulbs returned with a warranty claim form. If a replacement bulb is requested, it must be ordered from the sales department, and it will be shipped and invoiced as a sale.
5. All bulb invoices are to be paid within the established terms, without regard to any warranty claim.
6. Failure to remit invoices under the established terms will result in the owner being placed on COD status.
7. Bulbs returned to Xenotech-Strong International that are re-workable by the manufacturer will be reworked and returned to the owner.
8. Bulbs returned to Xenotech-Strong International that the manufacturer determines test satisfactorily will be returned to the owner.
9. Bulbs returned to Xenotech-Strong International that are defective and are covered under warranty and that are not re-workable will result in a credit being issued to the owners account in accordance to policy #10.
10. Bulbs covered by warranty, which have failed within the first 50 operating hours, will be credited in full. Credit for bulbs failing after more than 50 operating hours will be pro-rated as per the average life span of the bulb type (see #15).
11. Bulbs that have been overheated are not covered by warranty.
12. Bulbs that suffer any unusual damage not caused by normal wear are not covered by warranty.
13. Bulbs received at Xenotech-Strong International broken and not in their original container, with proper cushioning packing, are not covered by warranty.
14. The return authorization number must be written on the shipping label to be properly recognized and accepted by our Receiving Department.
15. Average Bulb Life Span:
 - 2kW Lamps are warranted for 2000 hours.
 - 4kW Lamps are warranted for 1000 hours.
 - 7kW Lamps are warranted for 500 hours.

Sky-Tracker Lamphed Assembly
2 - 4 kW

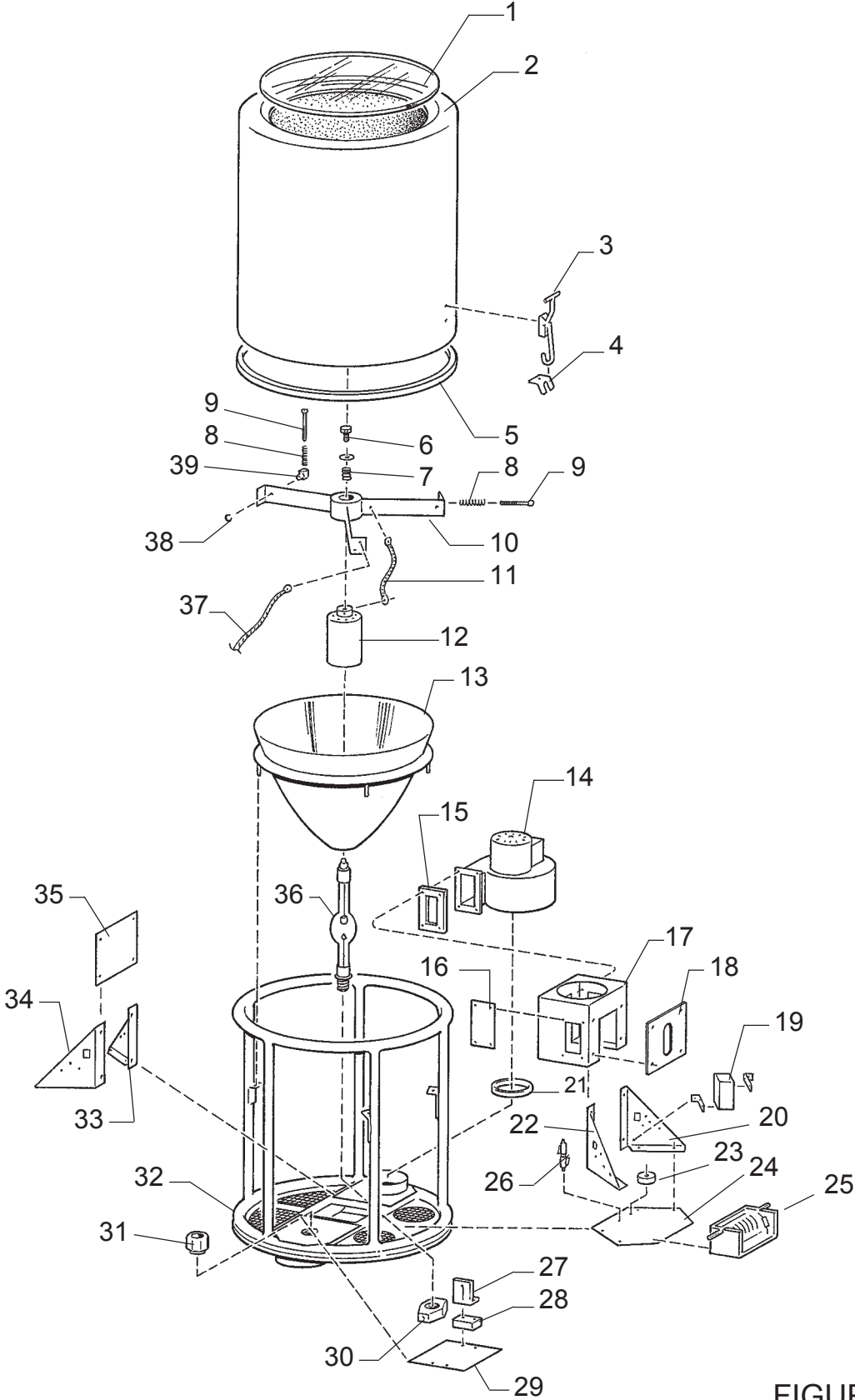

FIGURE 1

PARTS LIST

Figure 1

<u>Item</u>	<u>Part No.</u>	<u>Description</u>
1	31-98097	Cover Lens, Glass
-	11-98062	RTV Silicone Sealant (3 oz. Tube)
2	32-50024	Lamphead Housing, Fiberglass
3	31-18035	Latch (2 req'd.)
-	32-40463	Nut Plate, Latch (not shown)
4	23-40462	Catch (mounts to Item 33; 2 req'd.)
5	31-98098	Lower Gasket, Trimlock
6	41-51767	Shoulder Bolt, 5/16 x 3/4" 1/4-20 Thrd.
-	4317001	Flatwasher, 5/16"
7	31-58005	Compression Spring, .720" x .75"
8	31-58006	Compression Spring, .300" x 2.0"
9	4102000	Screw, 10-32 x 2" Socket Head
10	32-50013	Bulb Support Spider
-	31-61007	Thermal Switch
11	32-50244	Positive Lead (2 req'd.)
12	32-50177	Radiation Shield & Anode Clamp
13	32-50435	Reflector & Ring Assembly, Parabolic
14	32-50055	Blower, 220 V.AC, 50/60 Hz. (2 req'd. for 4 kW)
15	31-9813	Gasket, Blower Outlet
16	32-40090	Cover Plate
17	32-40088	Blower Box
18	32-20031	Insulator Plate
19	32-50032	Transformer (2 kW)
19	32-50033	Transformer (4 kW)
20	32-40084	Support Bracket, Right
21	32-20030	Ring, Blower Coupling
22	31-40083	Support Bracket, Left
23	39110000	Capacitor
24	32-40089	Base Plate, Lower Bulb Support
25	32-50036	RF Coil Assembly (2 kW)
25	32-50053	RF Coil Assembly (4 kW)
26	81-61018	Spark Gap
27	31-98076	Mounting Bracket, Cathode Receiver (2 req'd.)
28	32-20029	Spacer Block, Bracket (2 req'd.)
29	(ref.)	Plate (welded to Item 32 Frame)
30	31-98078	Cathode Receiver, Threaded
31	31-98163	Strain Relief Bushing
32	32-40098	Frame, Welded Assembly
33	32-40084	Support Bracket, Right

PARTS LIST, Figure 1 (continued)

<u>Item</u>	<u>Part No.</u>	<u>Description</u>
34	31-40083	Support Bracket, Left
35	32-40092	Blower Input Cover
-	32-40091	Blower Port Cover (not shown), 2kW only
36	31-30095	Xenon Bulb, 2 kW
36	31-30052	Xenon Bulb, 4 kW
37	32-50244	Positive Lead
-	31-98078	Negative Lead (to Power Supply; not shown)
38	31-98075	Snap Ring
39	32-20003	Focus Block

Sky-Tracker Lamphood Assembly
7 kW

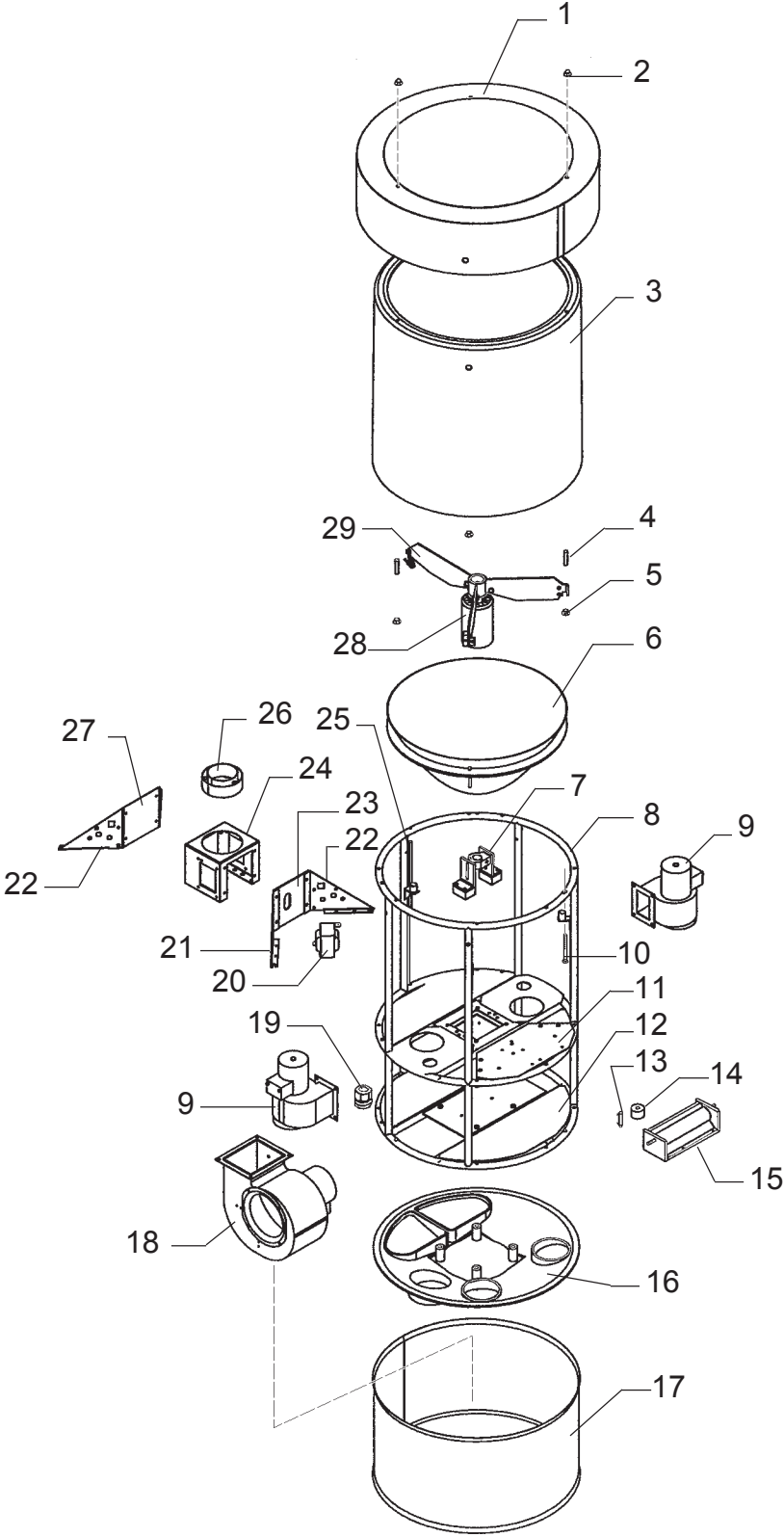
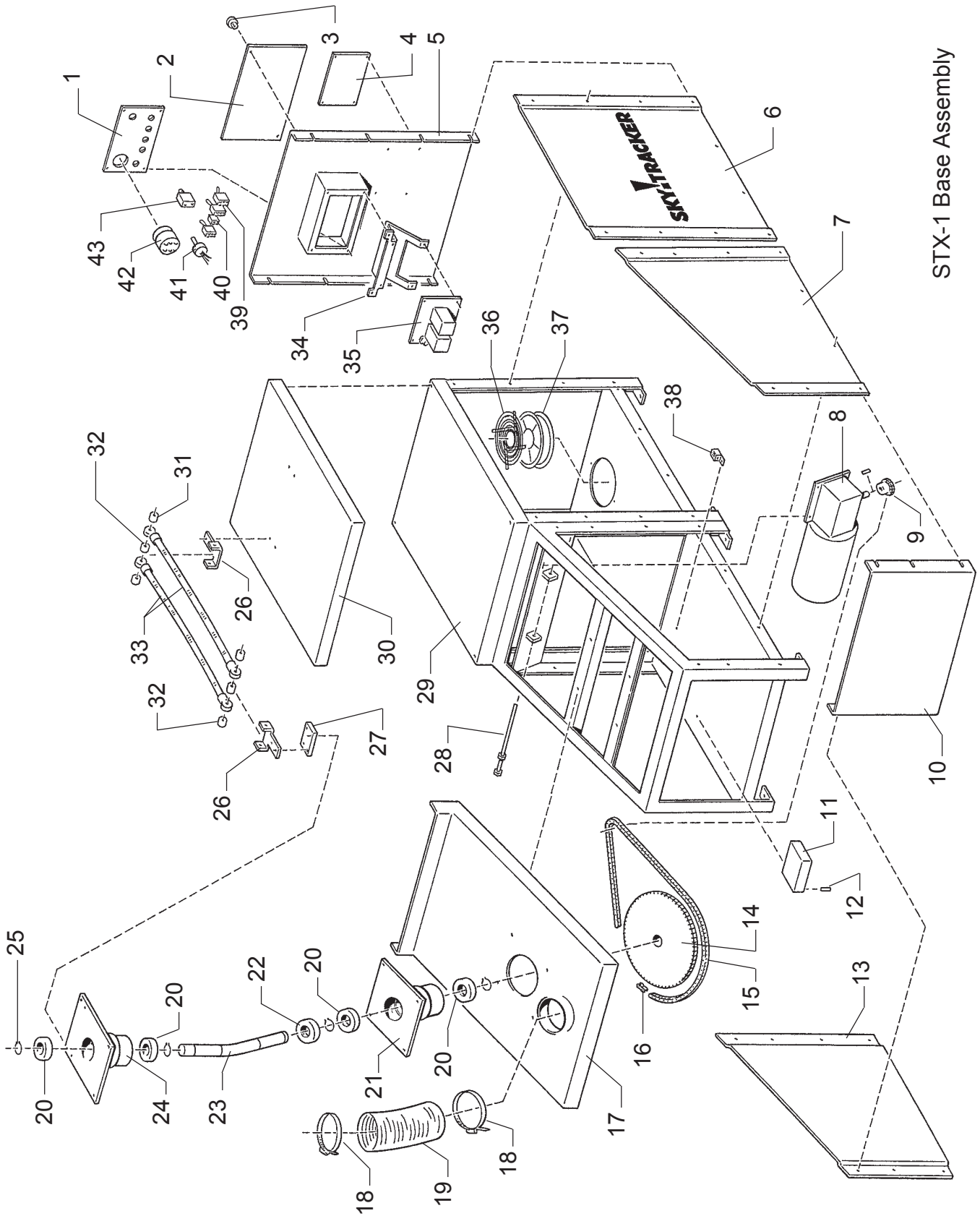

FIGURE 2

PARTS LIST

Figure 2

<u>Item</u>	<u>Part No.</u>	<u>Description</u>
1	32-00303	Cowl Assembly, 7 kW Lamphead
-	32-00251	Cowl, Welded Assembly
-	31-98097	Cover Lens, Glass
-	11-98062	RTV Silicone Sealant (3 oz. Tube)
2	4258008	Acorn Nut, 1/4-20 (3 req'd.); to Item 10
-	4257106	Washer, 1/4" Weatherseal (3 req'd.)
3	31-98096	Lamphead Housing, Fiberglass
4	32-00287	Cowl Spacer (3 req'd.); with Item 10
5	4257104	Washer, 1/4" (3 req'd.); with Item 10
6	32-50435	Reflector & Ring Assembly
7	32-50014	Bulb Receiver Assembly (see Figure 1, Items 27-30)
8	32-00169	Lamphead Frame, Welded Assembly
9	32-50055	Blower, 240 V.AC, 50/60 Hz.
10	4253500	Cowl Mounting Screw, 1/4-20 x 3-1/2" (3 req'd.)
11	32-40089	Igniter Base Plate
12	32-00269	Mid-Frame Cover Plate (3 req'd.)
13	31-61018	Spark Gap
14	39110000	Capacitor, High Voltage
15	32-50053	RF Transformer
16	31-29221	Lamphead Base, Molded
17	32-00182	Lamphead Extension Cover
18	32-00274	Blower, 240 V.AC, 50/60 Hz.
19	31-98163	Cord Grip Bushing
20	32-50032	High Voltage Transformer
21	32-40083	Igniter Base Support, Left (2 req'd.)
22	32-40084	Igniter Base Support, Right (2 req'd.)
23	32-00031	Insulator Plate
24	32-00188	Blower Mounting Box
25	32-00027	Focus Rod
-	32-00265	Focus Rod Spacer
-	4250620	Screw, 1/4-20 x 5/8" Socket Head
-	51-48004	Retaining Ring, External
26	32-00224	Ring Assembly, Blower Box
27	32-40090	Access Cover Plate
28	32-50117	Lamp Holder
-	41-51767	Shoulder Bolt, 5/16 x 3/4" 1/4-20 Thrd.
-	41-70005	Flatwasher, 5/16"
-	31-58005	Compression Spring, .720 x .75"
29	32-50013	Bulb Support Spider, Welded Assembly



STX-1 Base Assembly

FIGURE 3

PARTS LIST

Figure 3

<u>Item</u>	<u>Part No.</u>	<u>Description</u>
1	32-40166	Plate, Instrument Panel (less Components)
2	32-40197	Cover Plate
3	32-20088	Thumb Screw
4	61-39001	Name & Data Plate
5	32-40212	End Panel, Welded Assembly
6	32-40263	Side Panel, with Logo (2 req'd.)
-	31-34024	SkyTracker Logo, Self-Adhesive
7	32-40264	Left Side Panel, Motor Housing
8	31-33025	Gear Motor, 90 V.DC
9	31-59006	Drive Sprocket
10	32-40262	End Panel, Motor Housing
11	31-33003	Speed Control Assembly
12	41-98052	Stand-Off, 8-32 (4 req'd.)
13	32-40263	Right Side Panel, Motor Housing
14	31-59003	Driven Sprocket
15	31-98118	Roller Chain
16	31-98119	Master Link, Roller Chain
17	32-40257	Top Cover, Motor Housing
18	41-10045	Duct Clamp
19	31-26003	Flexible Air Duct
20	31-04005	Ball Bearing
21	32-20097	Lower Bearing Housing
22	31-36005	Seal
23	31-98386	Bent Shaft, Lamphead
24	32-20098	Upper Bearing Housing
25	31-48001	Snap Ring
26	32-40187	Spring Retaining Bracket (same as Item 31)
27	32-20175	Bracket Mounting Plate
28	32-20093	Motor Adjusting Stud
-	4258008	Acorn Nut, 1/4-20
-	4258001	Lock Nut, 1/4-20
29	32-40258	Base Frame, Welded Assembly
30	32-40259	Top Cover Plate
31	31-56002	Spacer, 1/4 x 1/4" (4 req'd.)
32	31-56003	Spacer, 1/4 x 1/2" (2 req'd.)
33	32-50023	Expansion Spring
34	32-40220	Stand-Off Bracket
35	32-70137	Timer Control PC Board
36	71307000	Blower Grille

PARTS LIST, Figure 3 (continued)

<u>Item</u>	<u>Part No.</u>	<u>Description</u>
37	71627000	Blower, 220 V.AC, 50/60 Hz.
-	88253000	Blower Cord & Plug
38	51-34013	Ground Lug
39	31-61048	Toggle Switch
40	31-61030	Pushbutton Switch
41	91-69004	Speed Control Potentiometer, 10k Ohm
42	31-32001	Elapsed Time Meter
43	31-72002	Circuit Breaker
-	32-70136	Control Panel Assembly (Items 1, 39-43)

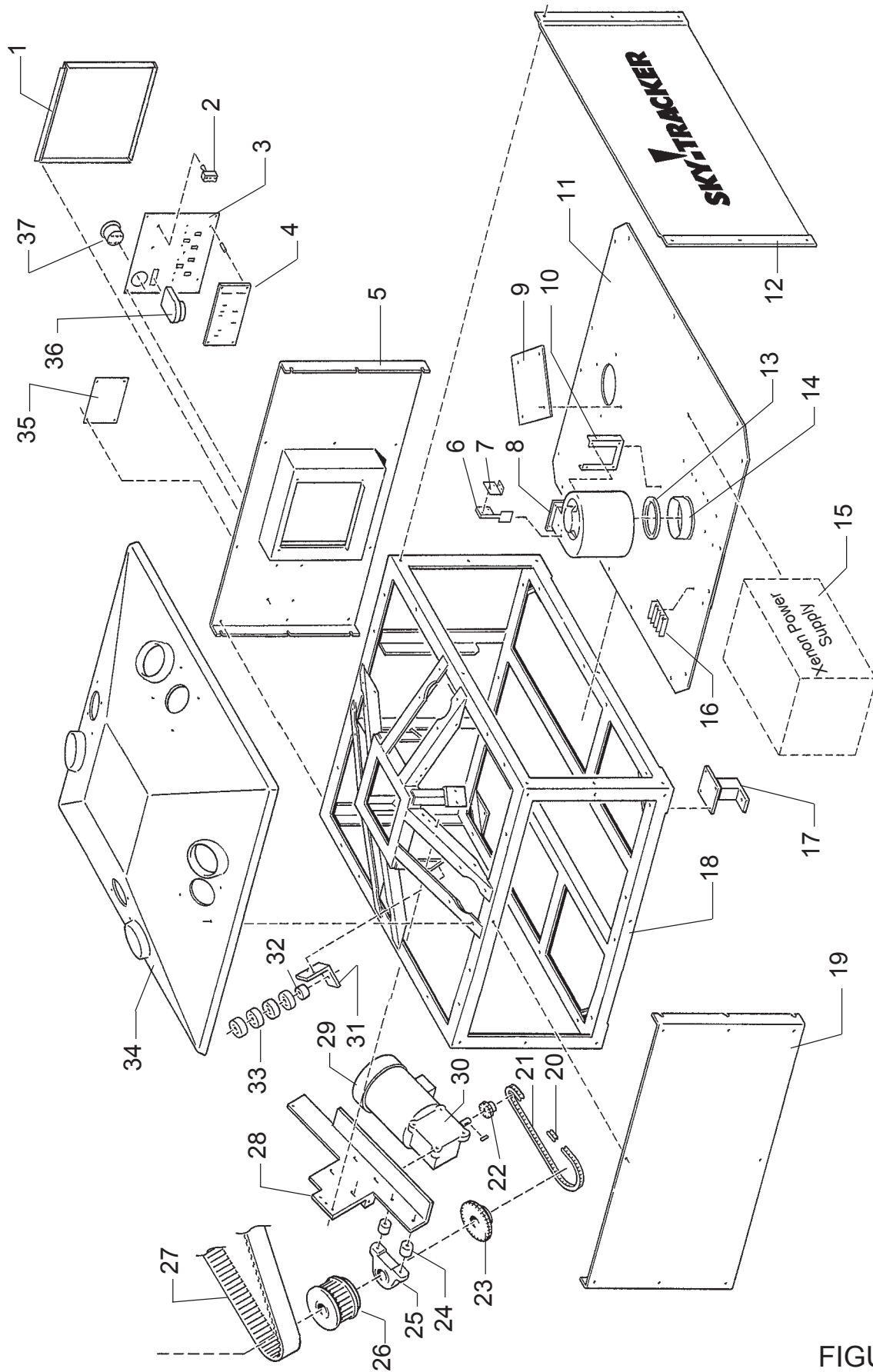

STX-4 Base Assembly

FIGURE 4

PARTS LIST

Figure 4

<u>Item</u>	<u>Part No.</u>	<u>Description</u>
1	32-40065	Instrument Panel Cover & Hinge
2	31-72002	Toggle Switch
3	32-40545	Instrument Panel Plate (less Components)
4	32-70242	Printed Circuit Board Assembly (208/230 V.AC)
4	32-70322	Printed Circuit Board Assembly (380/440 V.AC)
5	32-40060	End Panel, Operator's Side
6	39955000	Air Flow Switch
7	22-40854	Switch Mounting Bracket
8	11-02001	Blower, 230 V.AC, 50/60 Hz.
9	32-40425	Cover Plate (as req'd.)
10	32-00059	Mounting Flange
11	32-40150	Base Plate
12	32-40063	Side Panel (2 req'd.)
13	31-98121	Blower Intake Gasket (order 2 feet)
14	32-20107	Blower Coupling Collar
15	*	Xenon Power Supply (see Figure 5)
16	31-62009	Terminal Board
17	32-40265	Foot, Welded Assembly (4 req'd.)
18	32-40266	Base Frame, Welded Assembly
19	32-40071	End Panel, Off-Operator's Side
20	31-98248	Master Link, Roller Chain
21	31-98102	Roller Chain
22	31-59001	Drive Sprocket
23	31-59007	Driven Sprocket
24	32-20139	Spacer (2 req'd.)
25	31-04002	Pillow Block
26	31-43001	Drive Pulley, Timing Belt
27	31-05001	Timing Belt
28	32-40434	Motor Mounting Bracket
29	31-33024	Drive Motor
30	32-20084	Gearbox Assembly
31	32-40338	Bracket & Stud Assembly
-	32-20087	Stud Bushing (not shown)
32	32-20126	Spacer
33	31-04004	Ball Bearing (4 req'd.)
34	31-98100	Top Cover
35	61-39001	Name & Data Plate
36	40191000	Ammeter
37	31-32001	Elapsed Time Meter

PARTS LIST, Figure 4 (continued)

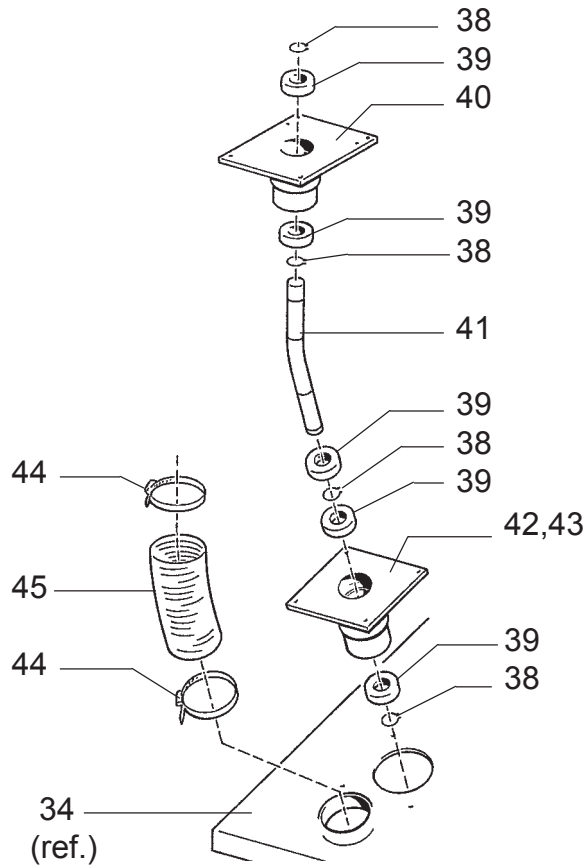

<u>Item</u>	<u>Part No.</u>	<u>Description</u>
38	31-48001	Retaining Ring
39	31-04005	Ball Bearing
40	32-20098	Upper Bearing Housing*
-	4253000	Mounting Screw, 1/4-20 x 3" Hex Head
-	4257000	Split Lockwasher, 1/4"
-	4257102	Flatwasher, 1/4"
41	31-98090	Bent Shaft, Short (3 req'd)
41	31-98091	Bent Shaft, Long (1 req'd.)
-	31-36005	Seal (not shown; above Item 39 Bearing)
42	32-20097	Lower Bearing Housing, Round Mounting Holes
43	32-20096	Lower Bearing Housing, Slotted Mounting Holes
-	4251001	Mounting Screw, 1/4-20 x 1" Hex Head
-	4257000	Split Lockwasher, 1/4"
-	4257102	Flatwasher, 1/4"
44	41-10045	Hose Clamp
45	31-26003	Air Duct Hose

* See Figure 3, Items 27 & 28 for Spring Bracket

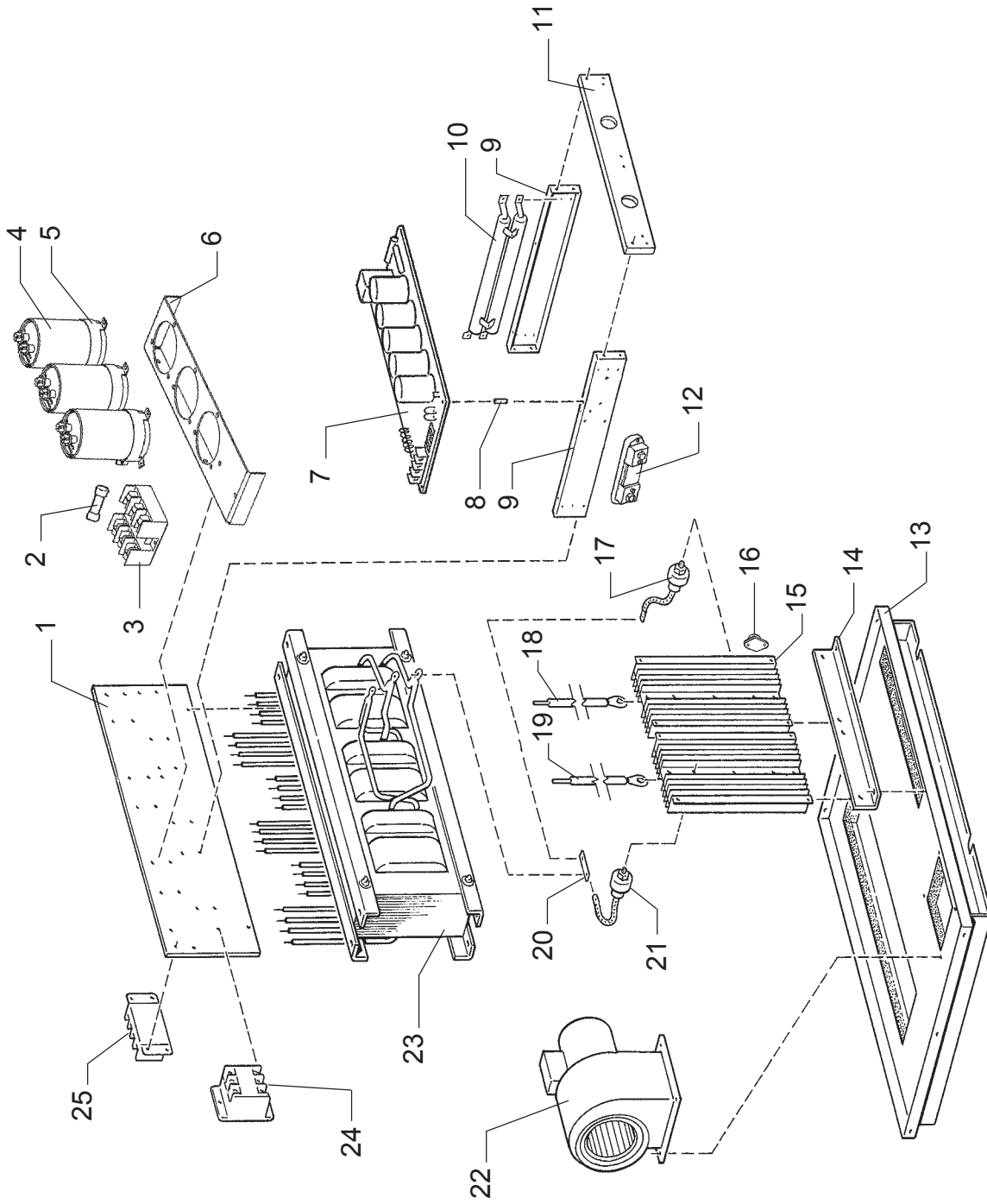

FIGURE 5

PARTS LIST

Figure 5

<u>Item</u>	<u>Part No.</u>	<u>Description</u>
1	82-40047	Terminal Board Mounting Plate, Phenolic
2	31-21005	Fuse, 20 A. 250 V. (replace with same rated fuse)
2	31-21038	Fuse, 30 A. 250 V. (replace with same rated fuse)
3	31-21054	Fuse Block
4	31-08133	Power Factor Capacitor (3 req'd.)
5	31-10001	Capacitor Clamp (3 req'd.)
6	32-40538	Capacitor Mounting Bracket
7	32-70318	Printed Circuit Board Assembly
8	41-56002	Spacer, PC Board (4 req'd.)
9	82-40040	Support Bracket, Rectifier Heat Sinks
10	81-46026	Ceramic Resistor (R1,2), 100 Ohm, 100 W.
11	82-40254	Heat Sink Mounting Plate, Phenolic
12	81247000	Shunt, 200 A.
13	32-40006	Chassis Plate, Welded Assembly
14	82-40255	Heat Sink Mounting Plate
15	82-20032	Heat Sink (2 req'd.)
16	81-61010	Thermal Switch
17	81-47004	Forward Diode (CR1,2,3), 100 A. 300 V. (1N3290)
18*	61-71010	Positive Lead (Red)
19*	61-71009	Negative Lead (Black)
-	94129000	Ring Terminal (2 per lead req'd.)
20	91-98031	Buss Bar (3 req'd.)
21	81-47001	Reverse Diode (CR4,5,6), 100 A. 300 V. (1N3290R)
22	81-33026	Squirrelcage Blower, 230 V.AC, 50/60 Hz.
23	91-64008	Power Transformer, 2000 Watt; 208/230 V.AC Input
23	91-64009	Power Transformer, 2000 Watt; 380/440 V.AC Input
23	91-64012	Power Transformer, 4000 Watt; 208/230 V.AC Input
23	91-64001	Power Transformer, 4000 Watt; 380/440 V.AC Input
23	91-64011	Power Transformer, 7000 Watt; 208/230 V.AC Input
23	91-64007	Power Transformer, 7000 Watt; 380/440 V.AC Input
<i>Item 23 Transformer includes Item 1 Mounting Plate & (6) Item 25 Terminal Blocks.</i>		
24	81-14003	Contactors
25	81-62001	Tap Terminal Block (6 req'd.)

* Order by *foot*

