

# INSTRUCTION MANUAL

## **STRONG “575”**

Follow Spotlight

Type 41000

Rev. April 2002



### **STRONG INTERNATIONAL**

a division of Ballantyne of Omaha, Inc.

4350 McKinley Street

Omaha, Nebraska 68112 USA

Tel 402/453-4444 • Fax 402/453-7238



## PREFACE

THE STRONG “575” FOLLOW SPOTLIGHT Model 41000 is an AC follow spot complete with lamphouse, igniter, power supply, optical system, and color boomerang. It is designed for use with the 575 watt metal halide bulb, Strong part number 41102.

THE “575” LAMPHOUSE has a deep ellipse cold-coated metal reflector designed to operate in a fixed position, with the bulb mounted horizontally in the lamphouse. The bulb is adjustable in relation to the reflector to permit positioning on the reflector optical center line. The igniter is contained in the base of the lamphousing.

THE SEPARATE POWER SUPPLY comes equipped with a three-wire AC line cord terminating in a 125 volt ( $\pm 10$  volt), 60 Hz. plug that can be connected to an AC outlet, and draws approximately 7 amperes from the line. The power supply also has two switches and a toggle type circuit breaker. The circuit breaker must be in the “ON” or “RESET” position to energize the power supply. “ON” and “OFF” switches on the power supply parallel those on the spotlight. A 230 volt, 50/60 Hz. power supply is shipped with Export Model 41001.

THE IGNITER in the lamphouse requires a 237 V.AC open circuit pulse, provided by a step-up transformer in the power supply, to ignite the bulb. After ignition, the power supply automatically drops the voltage to the value required to maintain the arc.

THE ADJUSTMENT CONTROL for positioning the metal halide bulb is located behind the cover panel at the rear of the lamphouse. This control mechanism permits focus adjustment of the bulb in relation to the reflector and also allows the bulb to be centered both vertically and horizontally on the optical center of the reflector.

THE LAMPHOUSE has a running time meter to indicate the number of hours the bulb has been used. It also has two switches for the “ON” and “OFF” control at the lamphouse. The lamp can be controlled from either the power supply or the lamphouse. To break the AC supply at the power supply and lamphouse, open the circuit breaker on the rear of the power supply.

THE POWER SUPPLY is attached to the lamphouse by a cable assembly approximately 13 feet long, terminating in an MS connector for easy attachment to the lamphouse. This cable assembly contains all the control wires for the operation of the lamphouse and power supply.

TWO BLOWERS are used in the follow spot system and operate from the 115 volt AC supply only while the bulb is ignited. One blower is used to cool the lamphouse and bulb; the other, in the lens mechanism, cools the color gels and lens system.

**PREFACE** (continued)

A HOUSING INTERLOCK SAFETY SWITCH inside the lamphouse on the rear of the lamp base pan opens the AC circuit in the lamphouse and prevents ignition of the bulb if the housing is not in the closed position.

COLOR TEMPERATURE REDUCTION filters, required for use with television and videotape, are available from theatrical supply dealers.

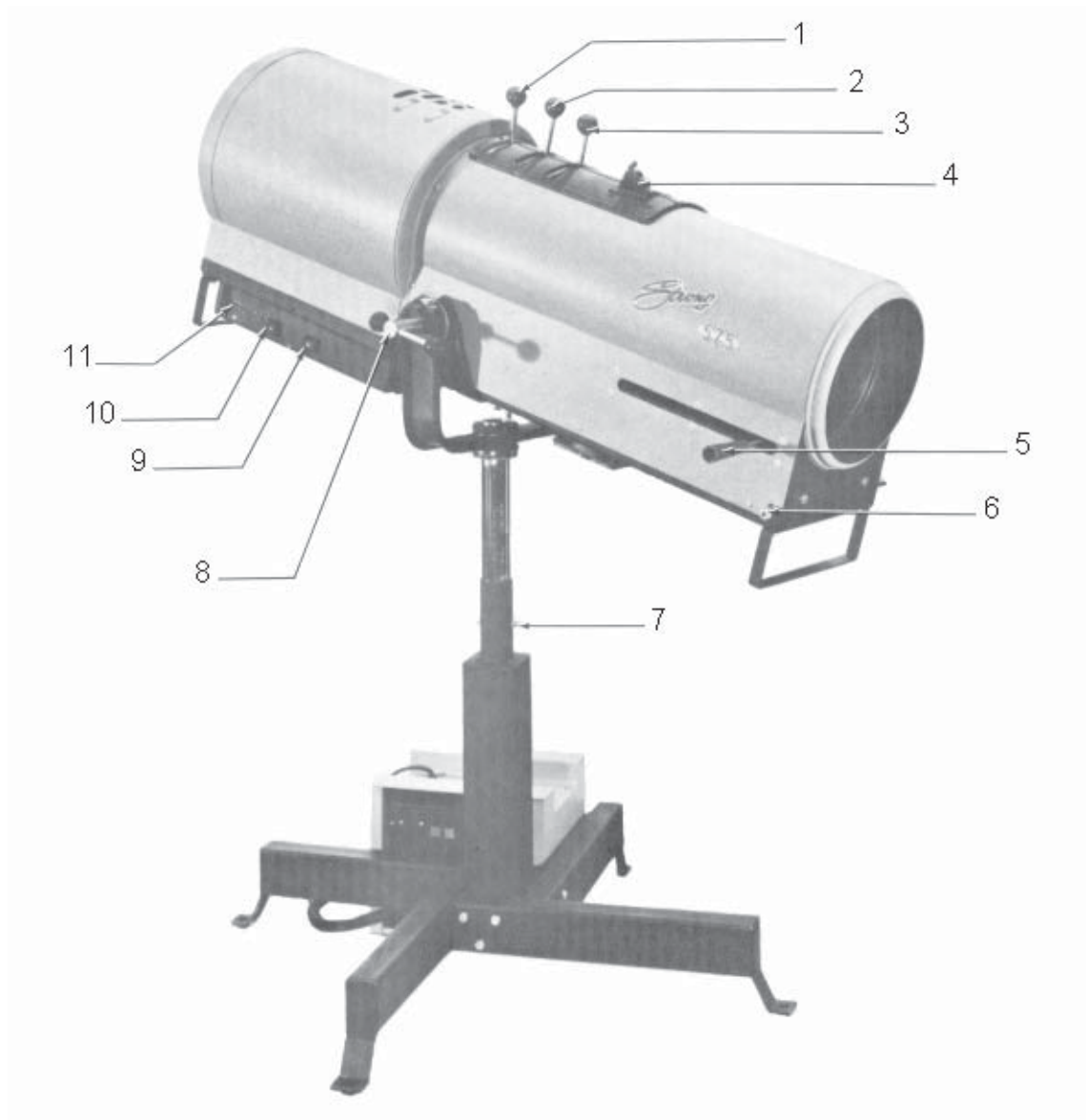

- 1. Fadeout Mechanism Control Lever
- 2. Masking Shutter Lever
- 3. Iris Control Lever
- 4. Color Boomerang
- 5. Spot Size Control Handle
- 6. Spot Focus Control Knob

- 7. Height Location Pin
  - 8. Vertical Tilt Locking Lever
  - 9. Lamp "OFF" Switch
  - 10. Lamp "ON" Switch
  - 11. Elapsed Time Meter
- Leveling Feet not shown*

## SETTING UP SPOTLIGHT

THE “575” FOLLOW SPOT is shipped in sections which must be assembled.

ASSEMBLE the four base legs to the square section of the center tube, using the 3/8-16 by 2-3/4 inch hex head cap screws and 3/8 inch split ring lockwashers to secure each leg. Insert a leveling foot and locknut in each of the four legs.

THE INNER TUBE and support yoke has four holes on four-inch centers and will allow an optical center height of approximately 46-1/2 inches, 50-1/2 inches, 54-1/2 inches and 58-1/2 inches above floor level to the optical center of the lamphouse and lens system. The leveling feet may be adjusted through a two inch range. Insert the height location pin through the hole in the outer tube and one of the holes in the inner tube so the retaining ball on the pin extends beyond the outer tube.

THE VERTICAL TILT locking lever is on the right hand (operating) side of the yoke assembly. Tighten this locking device securely before attempting to place the lamphouse and lens mechanism on the support yoke.

PLACE THE LAMPHOUSE and lens mechanism on the yoke assembly, with the lens control handle to the right hand (operator's side); the same as the locking lever on the yoke. Line up the four mounting holes in the bottom of the lamphouse and optical system support pan with four slotted holes in the support saddle and secure with the four 5/16-18 wing screws. Release the vertical tilt locking lever, move the lamphouse and optical system forward or back in the slots until the system is balanced. Then tighten the four wing screws to hold the system in balance.

CONNECT THE CABLE ASSEMBLY from the power supply to the mating receptacle on the bottom of the lamphouse and tighten firmly. The connector and receptacle are keyed to prevent misalignment of the pins. Do not connect the power supply to the AC supply at this time.

THE FOUR ANGLE BRACKETS on the base legs are designed as hold-down brackets for the spotlight. These brackets should be bolted to the floor or platform for safety purposes when the “575” spotlight is permanently installed. The casters are provided only for ease of movement to the operating location and must be removed from the base legs to ensure stability during use of the follow spot.

WHEN TRANSPORTING or hoisting the follow spot, DO NOT ATTEMPT TO LIFT the complete system, including the stand, by raising the lamphouse and lens mechanism. The most simple procedure is to release the tilt locking lever, and the hex head screw and nut on the off-operator side, just enough to permit lifting the lamphouse and support saddle from the yoke on the stand. Then, transport as two separate assemblies.

## BULB INSTALLATION AND OPERATION

REMOVE THE REAR COVER PLATE by pulling on the center section of the three retaining pins to release the plate. This will provide an opening to grasp when removing the lamp housing. Tighten securely the vertical tilt locking lever on the yoke. Remove the six screws attaching the housing to the base and loosen the one at top and front of the house. Slide the housing back and off the base for easy access to the bulb support.

ASSEMBLE THE BULB before installing it in the lamphouse. Keep fingers off quartz envelope. Remove the two knurled nuts from both ends of the bulb. Screw the front bulb extension (Part No. 41116) on the end of the bulb which has the evacuation or seal tip. This will place the seal away from the reflector and towards the front of the lamphouse. The best light is obtained with the envelope seal tip to the front of the lamphouse. Place the terminal on the end of the front bulb lead (with the banana plug) against the end of the bulb extension #41116. Use one of the knurled nuts to secure the lead to the extension. Make sure the connections are tight, being careful not to put any strain or fingerprints on the bulb envelope. The other knurled nut is not required; keep it for future use if needed.

PLACE THE END of the bulb without the lead through the center hole in the reflector, into the rear support collet. Loosen the small allen head screw in the collet so the metal end cap of the bulb can be fully inserted into the collet. Tighten the set screw firmly against the bulb's end cap to ensure a good electrical contact.

THE OTHER END of the bulb (with the extension and lead) must be positioned so it will seat at the bottom and center of the "Y" in the front support yoke. Insert the banana plug into the receptacle on the air duct.

SLIDE THE HOUSING back onto the base; note the sides of the housing should be inserted into the slots on the base. Do not replace the rear cover plate until the bulb alignment procedure (following) has been completed. Slide the cover under the top screw and replace the six screws along the bottom of the housing.

PLUG THE AC LEAD CORD from the power supply into any grounded three-wire, 15 ampere, 120 volt outlet. Set the circuit breaker on the rear of the power supply case to the "ON" or "RESET" position. Press the green "ON" switch at either the power supply or at the lamphouse and the bulb will ignite.

ALLOW THE BULB to heat up for two or three minutes to reach full brightness, then proceed with the following instructions for alignment of the bulb with the reflector.

## BULB INSTALLATION AND OPERATION(continued)

THE CENTER SECTION of the control is a threaded member that focuses the bulb in relation to the reflector. Turning this adjustment moves the bulb along the optical centerline of the reflector. Turning this section clockwise moves the bulb away from the reflector. The small knurled screw to the left of this section can be tightened to lock the focusing mechanism, after the following procedures have been completed.

THE THUMB SCREWS on either side of the focusing control lock the horizontal and vertical adjustment mechanism in position.

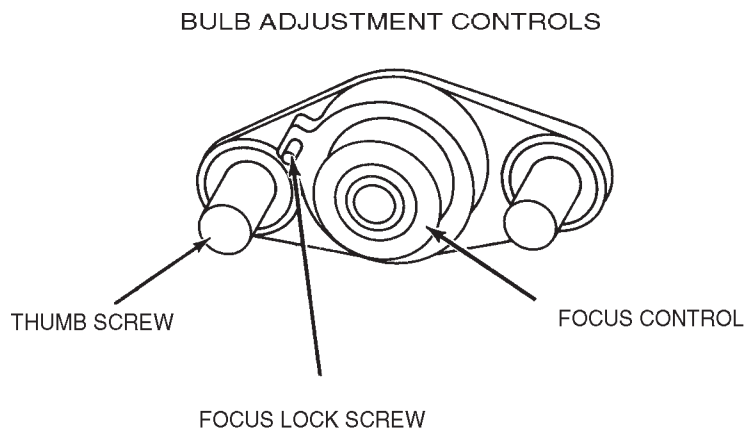

TO FOCUS THE METAL HALIDE BULB and obtain the best light on the stage the method outlined below is the most suitable.

MOVE THE SPOT SIZE CONTROL handle on the large lens carriage all the way forward to project the smallest spot possible, with the iris, the masking shutter and the dimming control or douser in the full open position. Project the spot to a wall or similar flat perpendicular area opposite the follow spot.

TURN THE CENTER FOCUSING SECTION of the bulb position control clockwise until a brown color with a hot spot is projected on the wall.

LOOSEN THE TWO THUMB SCREWS, one on either side of the center focusing section, just enough to permit manual movement of the complete assembly. The bulb adjustment control will now move around these two spring-loaded thumb screws.



## **BULB INSTALLATION AND OPERATION (continued)**

MOVE THIS CONTROL SECTION around the two screws until the hot spot is centered in the brown circle of the reflector. After the hot spot is centered, tighten the two thumb screws to lock this adjustment section and turn the center focus control section counterclockwise to obtain the brightest light with the best light distribution. Rotate the lens spot focus control knob, located on the front of the lens mechanism, to obtain the sharpest edge possible on the projected spot.

REPLACE THE REAR COVER PLATE over the bulb adjustment control mechanism. Secure using the push-type fasteners.

THE FOLLOW SPOT may be turned off at the lamphouse or the power supply, whichever is most convenient to the operator. It is recommended that the circuit breaker on the rear of the power supply be placed in the "OFF" position, to function as a line switch, when the spot is off for any extended period of time.

WHEN TRANSPORTING, or if the bulb may be subjected to a hard shock when moving to another location, remove the assembled metal halide bulb from the lamphouse by reversing the installation procedures. If the control section of the bulb adjustment is not changed, the bulb should be able to be replaced without any necessity to repeat the aligning procedures.

THE METAL HALIDE BULB ignites better when cold. After extinguishing the bulb, allow at least one minute cooling before attempting re-ignition.

EXPECTED BULB LIFE is 750 hours, but because of manufacturing tolerances, some bulbs may lose color quality before this period.

BULB LIFE can be maximized by avoiding repeated ignitions. Allow the lamp to burn throughout the spotlight's use cycle, dousing out with the masking shutter blades or fadeout mechanism as required.

RECORD the elapsed time meter reading when replacing a bulb.

## OPERATION OF OPTICAL SYSTEM

THE IRIS CONTROL is the front lever which projects through the top of the optical system housing. When this lever is to the left, looking at the spotlamp from the rear, the largest aperture is provided. Smaller apertures are obtained as the lever is moved to the right.

THE SPOT SIZE CONTROL HANDLE is located on the right side of the optical system just above the base pan. A variation of spot sizes from full flood to a small spot can be obtained by moving the spot size control from one extreme to the other. Beam intensity is increased by this optical system when reducing from flood to spot and maximum intensity is reached when the spot size control is in the extreme forward position.

THE MAXIMUM FLOOD SPOT is obtained with the iris control lever to the left (away from operating side) for the large aperture and with the spot size control handle moved as far as possible toward the rear.

SMALLER SIZED SPOTS are projected as the spot size control handle is moved forward. Most of the spot sizes needed will be produced with the iris in its maximum open position.

FOR A "HEAD SPOT," or any spot size smaller than can be obtained with the spot size control handle in its extreme forward position, shift the iris control lever to the right (toward operating side) for a smaller aperture. The iris control lever should always be returned to its extreme left position before the spot size control handle is again moved to obtain larger spots.

THE MASKING SHUTTER LEVER is the middle lever projecting through the top of the optical system housing. The masking shutter blades are operated by this lever to shape the projected spot to a rectangle, strip spot, or dousing.

THE DISENGAGED POSITION of the masking shutter lever is to the extreme right (toward operating side) and varying degrees of masking to complete cutoff are obtained by moving the lever to the left (away from operating side).

### CAUTION



ULTRAVIOLET RADIATION is emitted when the bulb is ignited. Wear protective clothing and goggles or glasses when adjusting the shutter blades or performing any service with the optical system housing removed.



## **OPERATION OF OPTICAL SYSTEM (continued)**

THE ANGLE OF THE MASKING SHUTTER BLADES can be adjusted to compensate for the horizontal projection angle. Remove large lens shaft handle and knobs. Remove the optical system housing, and loosen (with an angle screwdriver) the screws holding each of the masking shutter blades just enough to allow adjustment. Ignite the bulb and adjust the angle of the bottom blade by tapping with a screwdriver so its projected edge lies parallel to the footlights; tighten the mounting screw in the bottom blade.

OPERATE THE MASKING SHUTTER LEVER to close the blades. Adjust the upper blade to close in line with the bottom blade. Tighten the screw to secure the upper blade.

THE FADEOUT MECHANISM AND DOUSER CONTROL is the rear lever projecting through the top of the optical system housing. This lever controls the intensity of light from complete fadeout when the lever is to the left, to full intensity when the lever is to the right.

THE LENS FOCUSING KNOB is located on the operating side of the optical system base pan (forward end) and is used to adjust the optical system for the length of throw. When making an adjustment rotate the spot focusing knob until the sharpest edge is obtained on the projected spot. Moving the large lens to its center of travel and then adjusting for a sharp edge should give satisfactory results for the full movement of the lens system.

## **HANDLING THE SPOTLIGHT**

GENERALLY THE BEST POSITION for the operator to stand is near the center of the spotlight, on the right hand side, although the angle of tilt and the size of porthole may alter the position for the most convenient operation.

EACH OPERATOR will, after a few minutes of operation, generally develop his own system and preferred position for operating the follow spot.

THE VERTICAL TILT LOCK LEVER located on the base assembly can be set to give the required amount of friction on the spotlight to suit the individual operator.

THE LENS CARRIAGE FRICTION BRAKE is located on the outrider of the large lens carriage and is preset at the factory for the most satisfactory operation. Individual requirements vary and the brake can be adjusted to suit the operator. Remove the color boomerang, reach through the color gel opening and loosen the locknut. Then adjust the screw on the friction brake until the desired tension is applied to the large lens carriage. Tighten the locknut and replace the color boomerang.

## **OPERATION OF COLOR BOOMERANG**

THE COLOR BOOMERANG is equipped with six color filter discs containing the following colors in order from rear to front: (1) Amber, (2) Flesh Pink, (3) Daylight Blue, (4) Light Sky Blue, (5) Primary Blue, (6) Light Red. Keep the darkest or most dense colors to the front of the boomerang. A heat filter is mounted in a fixed position behind the boomerang to protect the gels.

THE SIX COLOR DISC LEVERS are mounted in the cover plate casting directly in front of the aperture selector lever. To insert a color disc in the light beam, move the proper color disc lever to the left as far as possible. To release a color disc, move the lever to the extreme right. Be sure that the lever is always fully returned to the limit of its movement.

TO REMOVE A COLOR DISC ASSEMBLY, remove the knobs from the aperture selector, masking shutter and fadeout levers. Remove the two end screws from the cover plate casting and lift off the complete boomerang assembly. The two split rivets holding the color disc assembly can now be removed and a new color disc assembly installed. Only the six above-mentioned color discs are supplied with the boomerang; additional colors are available from theatrical supply dealers.

## MAINTENANCE

TO CLEAN THE SMALL LENS, remove the color boomerang assembly and using a good grade of alcohol and piece of lens tissue (facial tissue can be used as a substitute), gently wipe both sides of the lens until the surface is clean.

THE BACK SURFACE OF THE LARGE LENS can readily be cleaned by using the same access hole as above with the large lens carriage in the rear position.

TO CLEAN THE FRONT SURFACE of the large lens, slide the lens carriage to the full forward position. The front surface is now readily accessible through the front of the housing.

THE REFLECTOR should be cleaned periodically with a clean, soft lint-free cloth to remove any dust from the reflecting surface. USE NO ABRASIVES.

THE NEGATIVE LENS, mounted on the support for the fadeout mechanism, must be removed for cleaning. Use the same materials for cleaning this lens as recommended for both the small and large lens. The negative lens must be replaced with the curved surface facing towards the reflector and metal halide bulb.

THE INSIDE of the lamphouse and lens mechanism and the blowers should be cleaned periodically, depending on the dust conditions at each installation. The blower blades and inlet grilles need cleaning to remove the dust buildup that accumulates over a period of time.

THE FOLLOW SPOT does not require any lubrication.

# LAMPHOUSE SCHEMATIC DIAGRAM

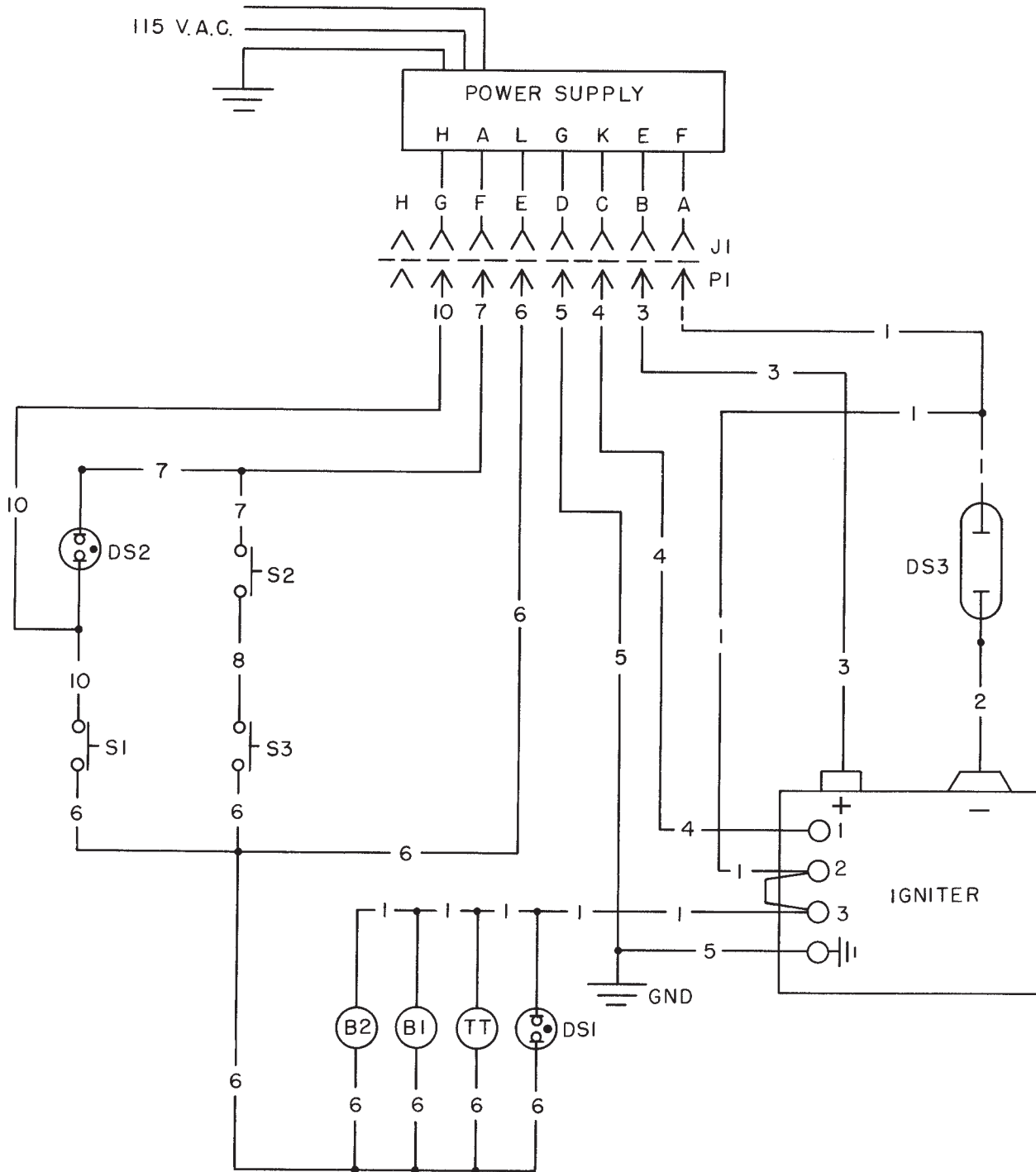

## PARTS LIST, SCHEMATIC DIAGRAM

Ref.	<u>Desig.</u>	<u>Part No.</u>	<u>Description</u>
-	-	41976	Igniter & Leads Assembly
-	-	41104	Igniter (220 V.AC, 50/60 Hz.)
-	-	41975	Igniter High Voltage Wire (2 req'd.)
B1	-	61-98002	Blower, Lamphouse (115 V.AC, 50/60 Hz.)
-	-	81272	Blower, Lamphouse (230 V.AC, 50/60 Hz.)
-	-	41970	Blower Lead, Lamphouse
B2	-	61-98002	Blower, Lens Mechanism (115 V.AC, 50/60 Hz.)
B2	-	81272	Blower, Lens Mechanism (230 V.AC, 50/60 Hz.)
-	-	41971	Blower Lead, Lens Mechanism
DS1	-	41188	Lamp & Switch ("ON" S1; 115 V.AC)
-	-	41193	Lamp & Switch ("ON" S1; 230 V.AC)
DS2	-	41189	Lamp & Switch ("OFF" S2; 115 V.AC)
-	-	41194	Lamp & Switch ("OFF" S2; 230 V.AC)
DS3	-	41102	HMI Bulb (575 Watt, Double-Ended)
-	-	41956	Lead Wire (TB1 to Duct) Assembly
-	-	41974	High Voltage Lead & Banana Plug (1)
J1	-	41111	Plug, Power Supply Cable <i>Cable Assembly furnished with Power Supply</i>
P1	-	41969	MS Receptacle, Wired Assembly
-	-	41110	MS Receptacle
S1	-	41967	"ON" Switch & Leads Assembly (DS1; 115 V.AC)
-	-	41188	"ON" Switch (115 V.AC)
-	-	41953	"ON" Switch & Leads Assembly (DS1; 230 V.AC)
-	-	41193	"ON" Switch (230 V.AC)
S2	-	41968	"OFF" Switch & Leads Assembly (DS2; 115 V.AC)
-	-	41189	"OFF" Switch (115 V.AC)
-	-	41954	"OFF" Switch & Leads Assembly (DS2; 230 V.AC)
-	-	41194	"OFF" Switch (230 V.AC)
S3	-	41973	Interlock Switch & Leads (115/230 V.AC)
-	-	80168	Interlock Switch, Housing (S3; 115/230 V.AC)
T1	-	41966	Elapsed Time Meter (115 V.AC, 60 Hz.)
-	-	41964	Elapsed Time Meter (230 V.AC, 50 Hz.)

*230 volt, 50 Hz. Components used in Export Model 41001*

FIGURE 1

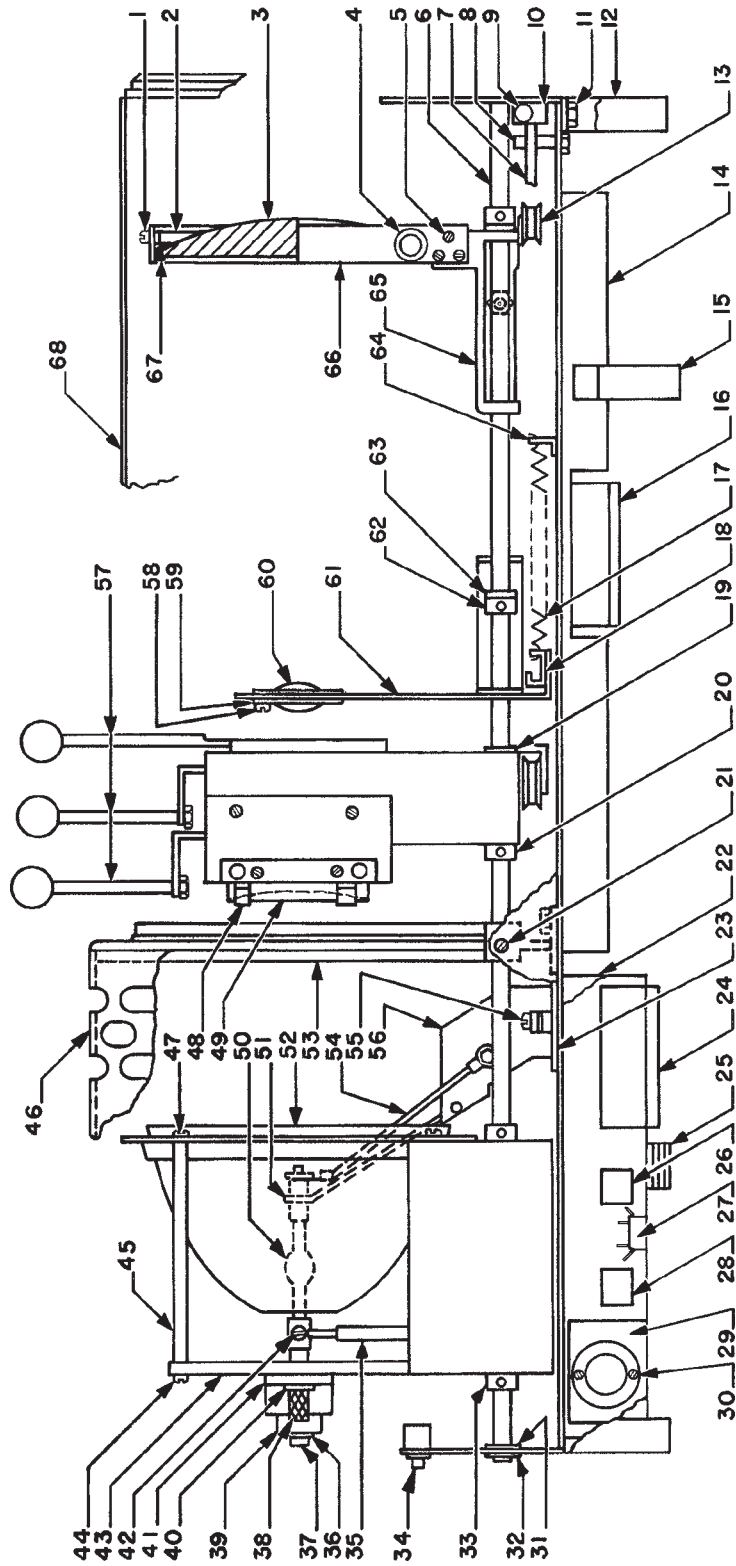

Lamphouse & Lens Mechanism



## PARTS LIST

Figure 1

<u>Item</u>	<u>Part No.</u>	<u>Description</u>
1	4080250	Screw, 8-32 x 1/4" Pan Head
-	4087001	Lockwasher, #8 Shakeproof (Bronze)
2	41152	Retaining Ring, Large Lens
3	41101	Lens, 9-1/2" Diameter, 20" F.L.
4	51509	Handle, Large Lens
-	41185	Shaft, Large Lens Handle
5	4110501	Screw, 10-24 x 1/2" Pan Head
-	4107001	Lockwasher, #10 Split Ring (as req'd.)
6	41134	Rod, Lens Carriage Slide
7	41958	Ribbon Assembly, Focus Adjusting
-	4060250	Screw, 6-32 x 1/4" Pan Head
-	4067000	Lockwasher, #6 Split
-	00919	Cotter Pin, 1/16" x 1/2"
8	45224	Stud, Lens Focus Adjusting
-	4250503	Screw, 1/4-20 x 1/2" Hex Head
-	4257000	Lockwasher, 1/4" Split Ring
9	51168	Knob, Focus Adjusting
-	4080120	Set Screw, Focus Adjusting Knob
-	41136	Threaded Rod, Focus Adjusting
-	4087101	Washer, 1/4" Flat
10	41135	Block, Lens Focus
11	4250503	Screw, 1/4-20 x 1/2" Hex Head
-	4257000	Lockwasher, 1/4" Split Ring
12	41173	Handle, Base Pan
13	51158	Pulley, Small
-	51160	Stud, Pulley
14	41994	Pan Assembly, Base
15	49361	Bracket, Handle (Used in early models <i>only</i> )
-	4310753	Thumbscrew, 5/16-18 x 3/4"
-	4317001	Lockwasher, 5/16" Shakeproof
-	4317102	Washer 5/16" Flat
-	49362	Grip, Vinyl Handle
16	61-98002	Blower, Lens Housing (125 V.AC, 50/60 Hz.)
-	81272	Blower, Lens Housing (230 V.AC, 50/60 Hz.)
-	83131	Guard, Blower

**PARTS LIST, Figure 1 (continued)**

<u>Item</u>	<u>Part No.</u>	<u>Description</u>
-	48316	Bushing, Nylon Snap
-	4062000	Screw, 6-32 x 2" Socket Head
-	4067001	Lockwasher, #6 Shakeproof
-	41971	Cord & Plug, Lens Blower
17	51162	Spring, Tension (Lens Carriage)
18	51120	Clip, Spring & Ribbon
-	4080250	Screw, 8-32 x 1/4" Pan Head
-	4087004	Lockwasher, #8 Shakeproof
19	91219	"E" Ring, External (Flat)
20	51114	Collar, Stop
-	4100180	Set Screw, 10-32 x 1/16" Cup Point, Allen Socket
21	4100250	Screw, 10-32 x 1/2" Pan Head
-	4107001	Lockwasher, #10 Shakeproof
22	41995	Welded Assembly, Instrument Case
-	4250508	Screw, 1/4-20 x 1/2" Pan Head
23	41139	Air Duct Insulator Plate, Fibreglass
24	61-98002	Blower, Lamphouse (115 V.AC, 50/60 Hz.)
-	81272	Blower, Lamphouse (230 V.AC, 50/60 Hz.)
-	83131	Guard, Blower
-	41970	Cord & Plug, Lamphouse Blower
-	4061000	Screw, 6-32 x 1" Pan Head
-	61127	Blower Mounting Clip
25	41969	MS Receptacle & Wires
-	41110	Receptacle, MS (less wires)
-	4040310	Screw, 4-40 x 5/16" Pan Head
-	4048001	Nut, 4-40 Hex
-	4047001	Lockwasher, #4 Shakeproof
26	41968	"OFF" Switch & Wires (115 V.AC)
-	41189	"OFF" Switch (115 V.AC)
-	41954	"OFF" Switch & Wires (230 V.AC)
-	41194	"OFF" Switch (230 V.AC)
27	81283	Block, Terminal
-	41142	Insulation Strip, Terminal Block
-	4080624	Screw, 8-32 x 5/8" Pan Head
-	4088001	Nut, 8-32 Hex
-	4087000	Lockwasher, #8 Split Ring

**PARTS LIST, Figure 1 (continued)**

<u>Item</u>	<u>Part No.</u>	<u>Description</u>
28	41967	“ON” Switch & Wired (115 V.AC)
-	41188	“ON” Switch (115 V.AC)
-	41193	“ON” Switch (230 V.AC)
29	41976	Igniter & Wires
-	41104	Igniter, High Voltage; 30 kV.
-	41146	Insulator, Igniter
30	41966	Meter, Elapsed Time (115 V.AC, 60 Hz.)
-	41964	Meter, Elapsed Time (230 V.AC, 50 Hz.)
-	41109	Plastic Cover, Hour Meter
-	4060310	Screw, 6-32 x 5/16" Pan Head
-	4067001	Lockwasher, #6 Shakeproof
31	46137	“E” Ring, External Bowed
32	91219	“E” Ring, External (Flat)
33	51114	Collar, Stop
-	4100180	Set Screw, 10-32 x 3/16" Cup Point, Allen Socket
34	80168	Switch, Interlock 115/230 V.
-	72178	Mounting Bracket, Interlock Switch
-	406037B	Screw, 6-32 x 3/8" Pan Head
-	4068001	Nut, 6-32 Hex
-	4067001	Lockwasher, #6 Shakeproof
35	41975	Wire Assembly, Igniter H.V.
36	21-48027	Ring, Truarc
37	25118	Bulb Support Assembly
-	408025C	Set Screw, 8-32 x 1/4" Cup Point (Bulb Retaining)
38	37985	Thumb Screw, Bulb Adjustment Locking
-	15010	Compression Spring
39	65959	Focus Screw & Bearing Assy.
40	65150	Fender Washer, Flat
41	65116	Bulb Adjust Casting
-	65153	Thumb Screw, Focus Lock
-	65154	Focus Locking Ball, Nylon
42	4080250	Screw, 8-32 x 1/4" Pan Head
-	4087001	Lockwasher, #8 Shakeproof
43	41992	Reflector Support
-	48324	Bushing, Wire
44	4250508	Screw, 1/4-20 x 1/2" Pan Head
-	4257001	Lockwasher, 1/4" Shakeproof

**PARTS LIST, Figure 1 (continued)**

<u>Item</u>	<u>Part No.</u>	<u>Description</u>
45	41140	Rod, Reflector Mounting
46	41963	Lamphouse Cover, Welded Assembly
-	41124	Danger Sign, Lamphouse
-	01639A	Rivet, 1/8" Domed Head
-	4080310	Screw, 8-32 x 5/16" Pan Head
-	41961	Rear Access Plate Assembly
-	41179	Cover, Lamphouse Access
-	45270	Plastic Plunger, Cover Plate
-	45271	Plastic Grommet, Cover Plate
47	4250508	Screw, 1/4-20 x 1/2" Pan Head
-	4257001	Lockwasher, 1/4" Shakeproof
48	44154	Clip, Lens Retaining
-	4080310	Screw, 8-32 x 5/16" Pan Head
-	4087001	Lockwasher, #8 Shakeproof
49	41119	Lens, Negative
50	41102	Lamp, HMI 575 Watt
-	41116	Threaded Extension, HMI Bulb 575 W.
51	41980	Bulb Support Yoke
52	23756	Reflector, Flanged
53	41114	Housing Support Casting
-	4250503	Screw, 1/4-20 x 1/2" Hex Head
-	4257000	Split Lockwasher, 1/4"
-	41945	Light Shield, Ring & Plate (not shown)
-	4080310	Screw, 8-32 x 5/16" Pan Head
54	41975	Wire Assembly, High Voltage Bulb Lead
55	4251007	Screw, 1/4-20 x 1" Truss Head
-	65171	Lava Bushing
-	48126A	Washer, Insulating
56	41155	Air Duct Casting
-	41139	Air Duct Insulator Plate, Fibreglass (ref. Item 23)
-	72181	Receptacle, Banana Plug
-	4100310	Screw, 10-32 x 5/16" Pan Head
-	4107001	Lockwasher, #10 Shakeproof
-	408025C	Set Screw, 8-32 x 1/4" Hex Socket
57	-	Fadeout, Chopper & Iris (See Figure 2)

**PARTS LIST, Figure 1 (continued)**

<u>Item</u>	<u>Part No.</u>	<u>Description</u>
58	4080183	Screw, 8-32 x 3/16" Pan Head
-	4087001	Lockwasher, #8 Shakeproof
59	41165	Ring, Small Lens Retaining
60	41108	Lens, 2" Diameter, 4-1/2" F. L.
61	41959	Carriage, Small Lens
62	51114	Collar, Stop
-	4100252	Set Screw, 10-32 x 1/4" Cup Point
63	51479	Washer, Rubber
64	41171	Bracket, Spring
-	4080310	Screw, 8-32 x 5/16" Pan Head
-	4087001	Lockwasher, #8 Shakeproof
65	41122	Support Casting, Large Lens
-	4251001	Brake Screw, 1/4-20 x 1" Hex Head (Nylon)
-	4258015	Lock Nut, 1/4-20 Hex (Nylon)
66	41981	Support Ring, Large Lens
67	41192	Rubber Edge, Large Lens
68	41965	Lens Housing
-	23059A	Insignia, "Strong"
-	01639-5	Rivet 1/8" Domed
-	41107	Insignia, "575"
-	41125	DANGER Sign, Lens Housing
-	48892	Rubber Baffle, Lens Carriage
-	4080377	Screw, 8 x 3/8" Self Tapping
-	4080310	Screw, 8-32 x 5/16" Pan Head

DETAIL, Figure 1, Items 36-41

37985	Thumb Screw (2 req'd.)
15010	Compression Spring (2 req'd.)
65116	Casting, Adjustment Mechanism
65150	Fender Washer (2 req'd.)
65153	Focus Lockscrew
65154	Nylon Locking Ball
65959	Focus Screw & Bearing Assembly
21-48027	Snap Ring, Collet Retaining
25118	Collet

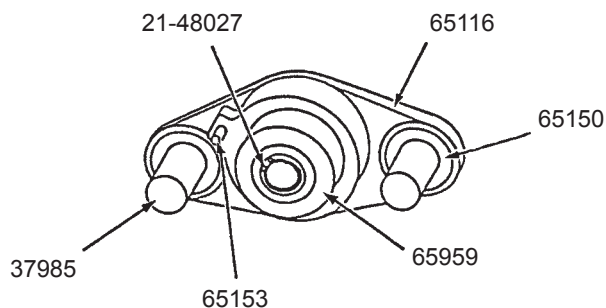
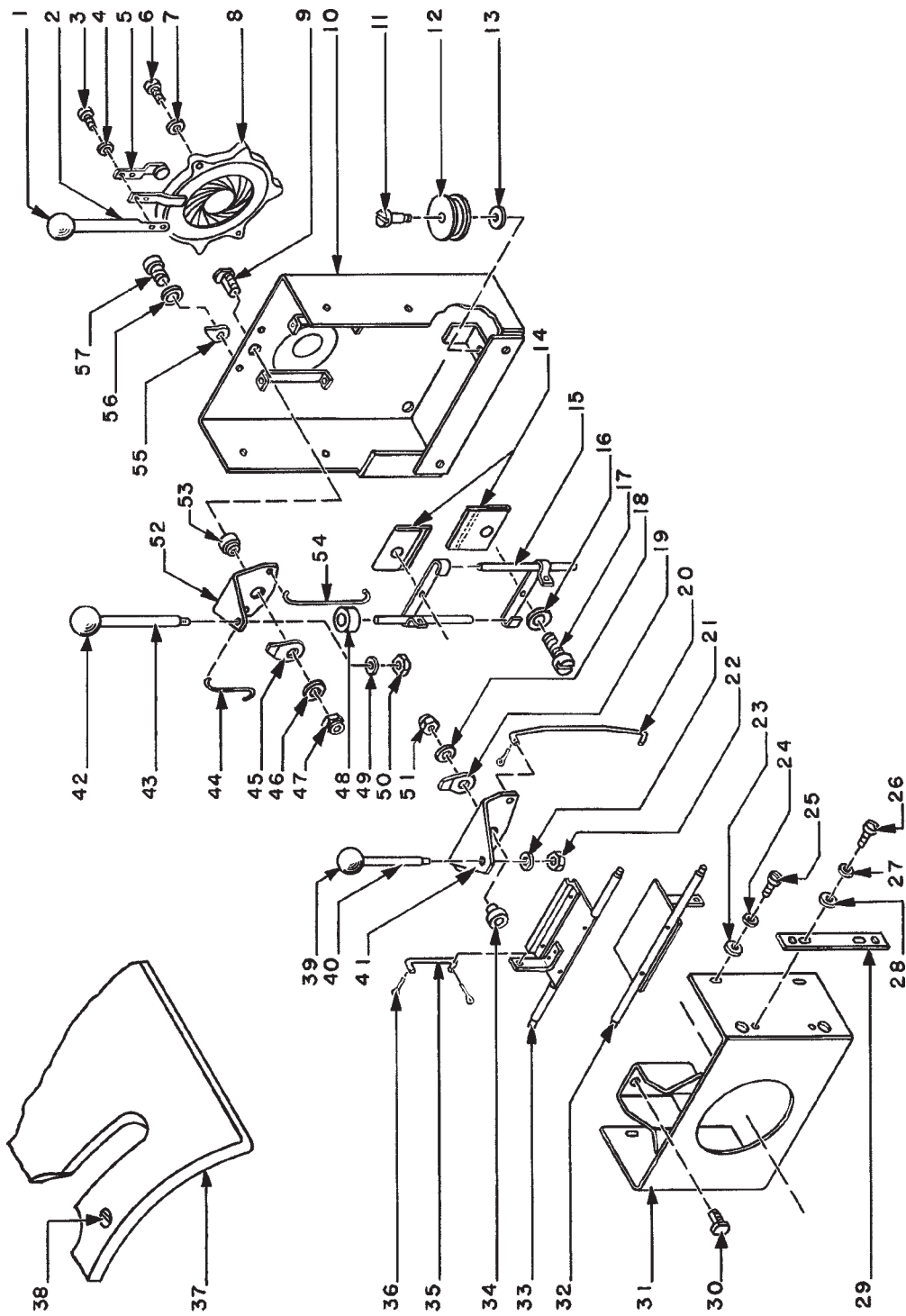

FIGURE 2



Optical System

## PARTS LIST

Figure 2

<u>Item</u>	<u>Part No.</u>	<u>Description</u>
1	10048A	Knob
2	51451	Shaft, Iris
3	4060310	Screw, 6-32 x 5/16" Pan Head
4	4067001	Lockwasher, #6 Shakeproof (as req'd.)
5	51978	Friction Spring & Button
-	51229	Friction Pad
6	4060620	Screw, 6-32 x 5/8" Pan Head
7	4067001	Lockwasher, #6 Shakeproof (as req'd.)
8	51979	Iris
9	51226	Stud
10	41988	Support Plate, Aperture
11	51160	Stud, Pulley
12	51157	Pulley, Large
13	4087100	Washer, #8 Brass Flat
14	47191	Masking Blade
15	47982	Slide Assembly, Masking Blades
16	4087001	Lockwasher, #8 Split Ring
17	4080181	Screw, 8-32 x 3/16" Pan Head
18	4257102	Washer, 1/4" SAE
19	51156	Friction Plate
20	51602	Rod, Long; Fadeout
21	4107001	Lockwasher, #10 Shakeproof
-	4257102	Washer, 1/4" Flat
22	4258001	Nut, 1/4"-20 Hex
23	4107100	Washer, #10 Brass
24	4107001	Lockwasher, #10 Shakeproof
25	410050B	Screw, 10-32 x 5/16" Pan Head
26	410050B	Screw, 10-32 x 5/16" Pan Head
27	4108001	Lockwasher, #10 Shakeproof (as req'd.)
28	4107101	Washer, #10 Flat SAE
29	51443	Retaining Strip, Fadeout
30	51226	Stud
31	41985	Support Assembly, Fadeout
32	51917	Blade Assembly, Lower
33	51916	Blade Assembly, Upper

**PARTS LIST, Figure 2 (continued)**

<u>Item</u>	<u>Part No.</u>	<u>Description</u>
34	41150	Bushing, Spacer
35	51515	Pull Rod, Short, Fadeout
36	01704	Spring Pin
37	41115	Cover plate
38	4250508	Screw, 1/4-20 x 1/2" Pan Head
39	10048A	Knob
40	51452	Shaft Fadeout Mechanism
41	41148	Bracket, Fadeout Handle
42	10048A	Knob
43	51452	Shaft, Masking Blades
44	51498	Pull Rod, Short, Masking Blade
45	51156	Friction Plate (replace with 4507106 Friction Washer)
46	4317102	Washer, 5/16" Flat
47	4318004	Nut, 5/16-18 x 1/4" FlexLock
48	MAL-64	Spacer ( <i>not used in "575" Spotlight</i> )
49	4257000	Lockwasher, 1/4" Split Ring
-	4257102	Washer, 1/4" Flat
50	4258001	Nut, 1/4-20 Hex
51	4318004	Nut, Flexlock 5/16-18 x 1/4" Thick
52	48406	Masking Blade Handle Bracket
53	51153	Spacer Bushing
54	51497	Pull Rod, Long Masking Blade
55	47170	Clip
56	4087001	Lockwasher, #8 Shakeproof
57	4080181	Screw, 8-32 x 3/16" Pan Head

NOTE

- 41989 Aperture Plate, Masking Blades & Iris Assembly  
Consists of Items 1 through 17, 42 through 50 & 52 through 57
- 41986 Fadeout Mechanism & Blades Assembly  
Consists of Items 18-36, 39-41, & item 51



FIGURE 3

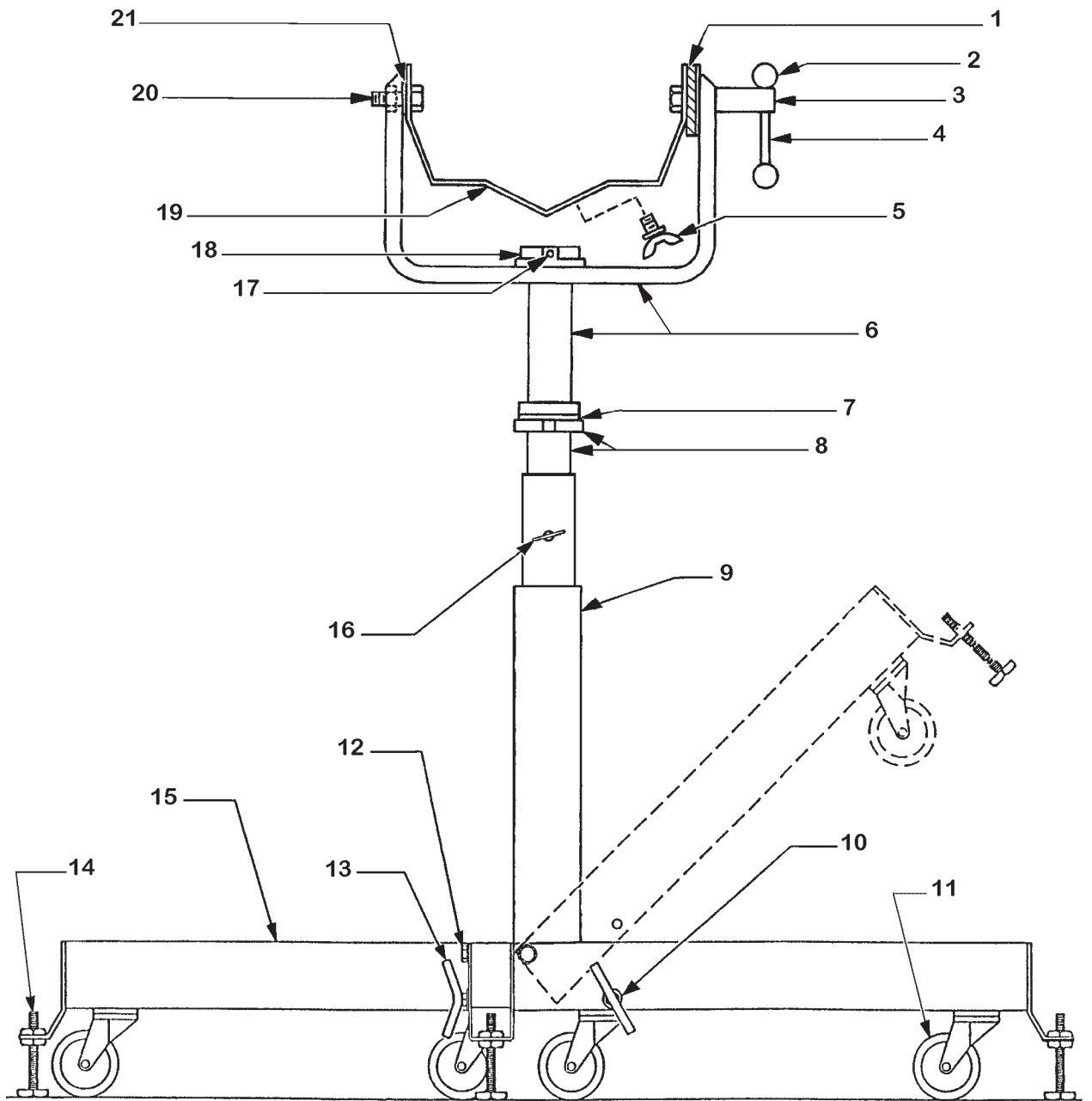

Yoke & Folding Floor Stand

## PARTS LIST

Figure 3

<u>Item</u>	<u>Part No.</u>	<u>Description</u>
-	65831	Yoke & Floor Stand Assembly
1	41133	Friction Washer
2	10048A	Knob
3	41149	Shaft, Clamp
-	45152	Bolt, Tilt Axis
4	49130	Handle
5	4310753	Thumb Screw, 5/16-18 x 3/4"
-	4317001	Lockwasher, 5/16" Shakeproof
-	4317102	Washer, 5/16" Flat
6	41960	Yoke, Welded Assembly
7	48399	Washer, Bronze
8	48885	Column Assembly, Inner
9	83742	Base Column, Welded Assembly
10	4377013	Flatwasher, 3/8"
11	49208	Swivel Caster
12	4433000	Screw, 7/16-14 x 3" Hex Head
13	83745	Leg T-Bolt, Welded Assembly
14	49926	Leveling Foot
15	83744	Base Leg, Welded Assembly
16	48395	Pin, Height Adjustment
17	4360370	Set Screw, 1/4-28 x 3/8" Dog Point
18	49191	Collar, Inner Tube
19	41123	Base Pan Saddle
20	4501250	Screw, 1/2-13 x 1 1/4" Hex Head
-	4508004	Nut, (FlexLock) 1/2-13 Hex
21	4507105	Washer, 1/2" Flat

FIGURE 3a

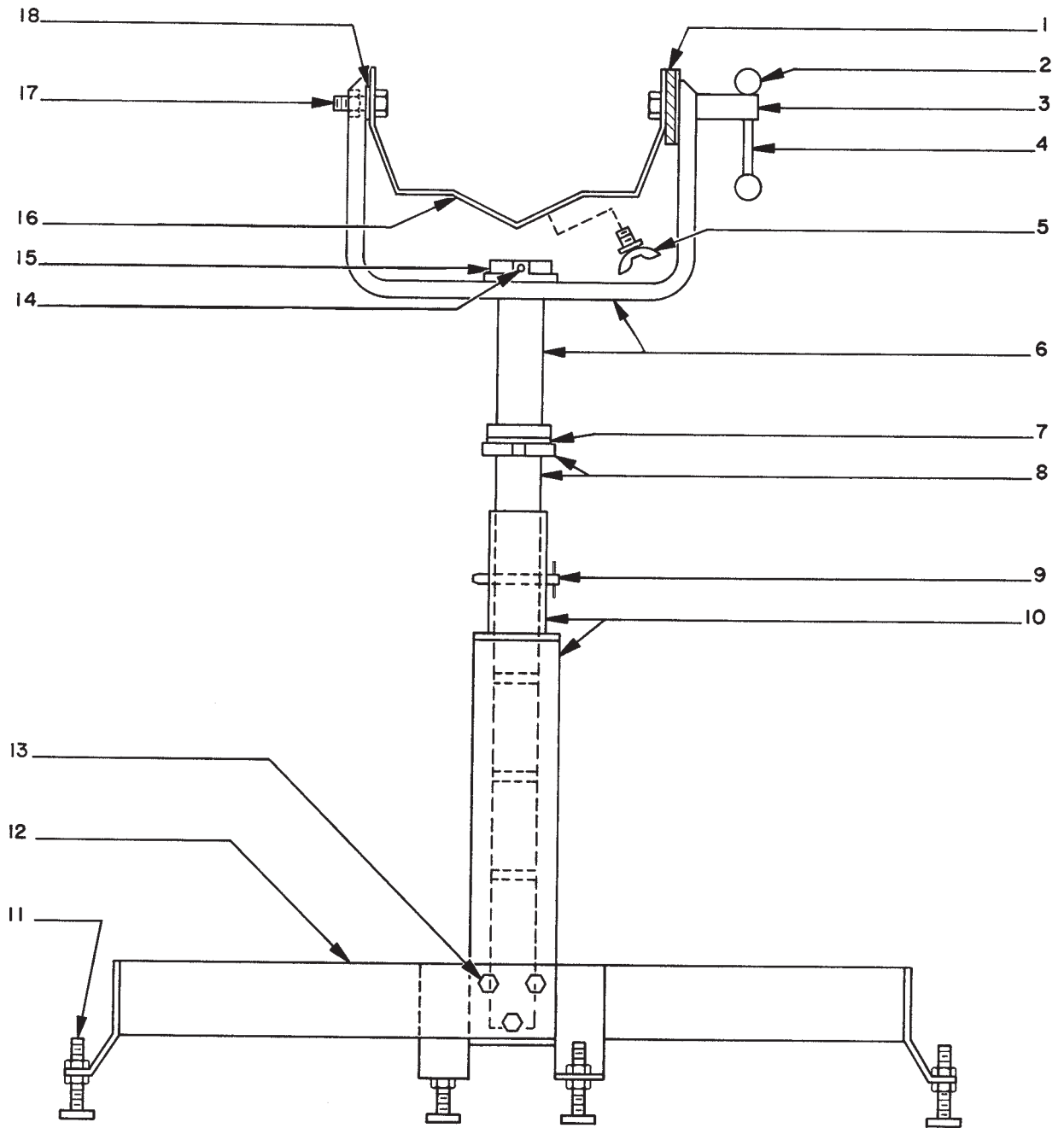

Yoke & Rigid Floor Stand

## PARTS LIST

Figure 3a

<u>Item</u>	<u>Part No.</u>	<u>Description</u>
-	41999	Yoke & Floor Stand Assembly
1	41133	Friction Washer
2	10048A	Knob
3	41149	Shaft, Clamp
-	45152	Bolt, Tilt Axis
4	49130	Handle
5	4310753	Thumb Screw, 5/16-18 x 3/4"
-	4317001	Lockwasher, 5/16" Shakeproof
-	4317102	Washer, 5/16" Flat
6	41960	Yoke Welded Assembly
7	48399	Washer, Bronze
8	48885	Column Assembly, Inner
9	48395	Pin, Height Adjustment
10	48888	Column Assembly, Outer
11	49226	Adjustable Foot
-	4508006	Nut, 1/2-13 Hex
12	48887	Leg Assembly
13	4312500	Screw, 5/16-18 x 2-1/2" Hex Head
-	4317000	Lockwasher, 5/16" Split
14	4360370	Set Screw, 1/4-28 x 3/8" Dog Point
15	49191	Collar, Inner Tube
16	41123	Base Pan Saddle
17	4501250	Screw, 1/2-13 x 1-1/4" Hex Head
-	4508004	Nut, (FlexLock) 1/2-13 Hex
18	4507105	Washer, 1/2" Flat

### PARTS NOT SHOWN

34014A Caster

---

FIGURE 4

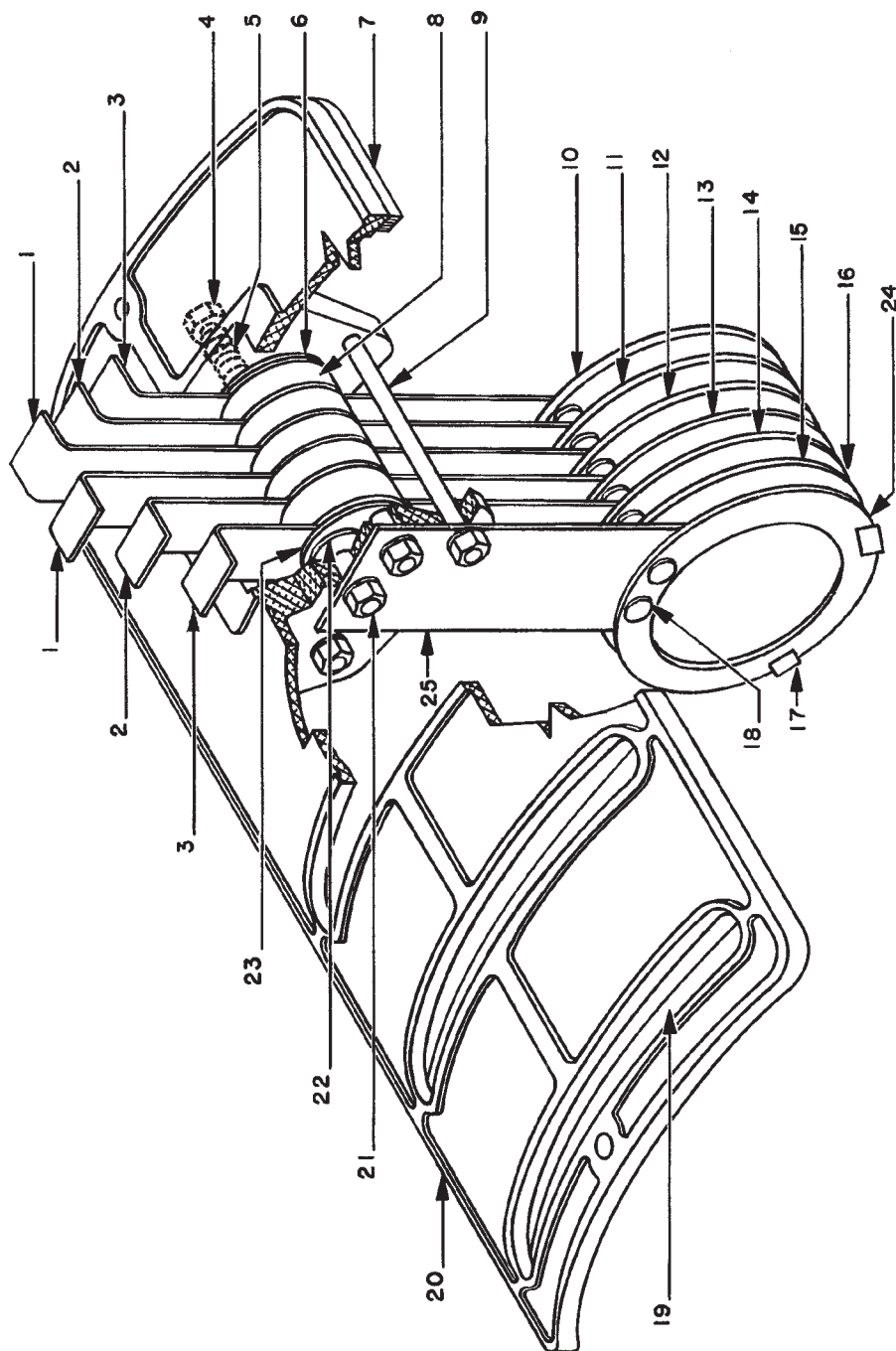

Color Boomerang Assembly

## PARTS LIST

Figure 4

<u>Item</u>	<u>Part No.</u>	<u>Description</u>
1	45131	Handle, Long
2	45130	Handle, Intermediate
3	45129	Handle, Short
4	4254000	Bolt, 1/4-20 x 4" Hex Head
5	01026	Spring
6	45133	Spacer, Thin
7	-	Rubber Seal 1/4" x 1/8" x 40" Long
8	45134	Spacer
9	4253500	Bolt, 1/4-20 x 3-1/2" Hex Head
10	45981	Color Disc Assembly (Light Red)
11	45982	Color Disc Assembly (Primary Blue)
12	45983	Color Disc Assembly (Light Sky Blue)
13	45984	Color Disc Assembly (Daylight Blue)
14	45985	Color Disc Assembly (Flesh Pink)
15	45986	Color Disc Assembly (Golden Amber)
*	41944	Color Discs, Set of Six (Items 10-15)
16	45122	Color Frame
17	46150	Clip
18	01456	Paper Fastener
19	41141	Rubber Baffle
20	41115	Cover Plate Casting
21	4258015	Nut, 1/4-20 Hex (Nylon)
-	4257001	Washer, 1/4" Shakeproof
22	4257102	Washer, 1/4" SAE Std.
23	45133	Spacer, Thin
24	41946	Heat Filter Disc Assembly
25	41199	Heat Filter Mounting Bracket

HMI POWER SUPPLY  
 Equipment Type 27002-01  
 June 1989 - present

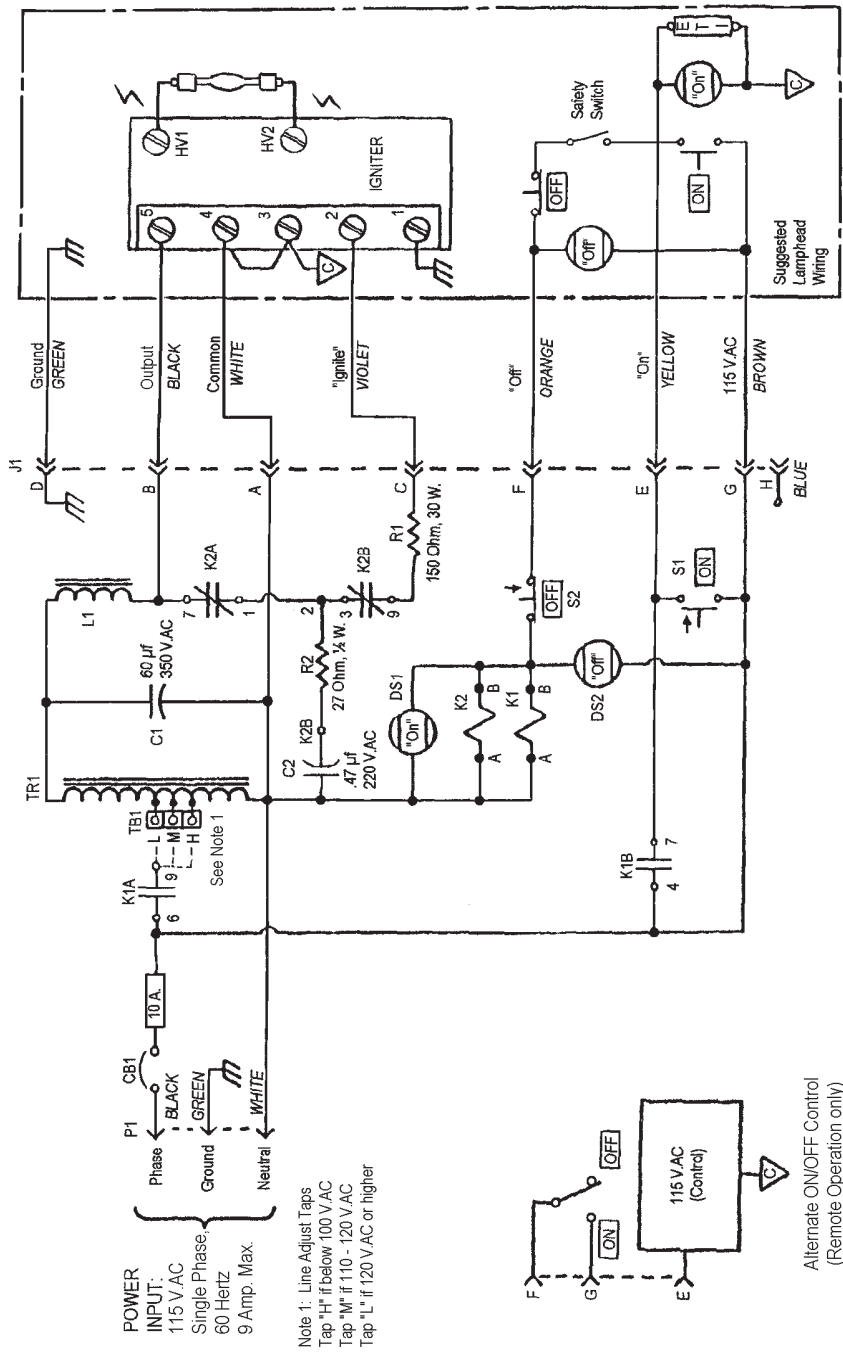

L.P Associates Inc.  
 6650 Lexington Avenue  
 Hollywood, California 90063  
 Tel. 213/462-4714

HMI POWER SUPPLY  
 Equipment Type 27000-01  
 July 1982 - June 1989

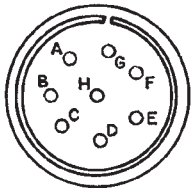
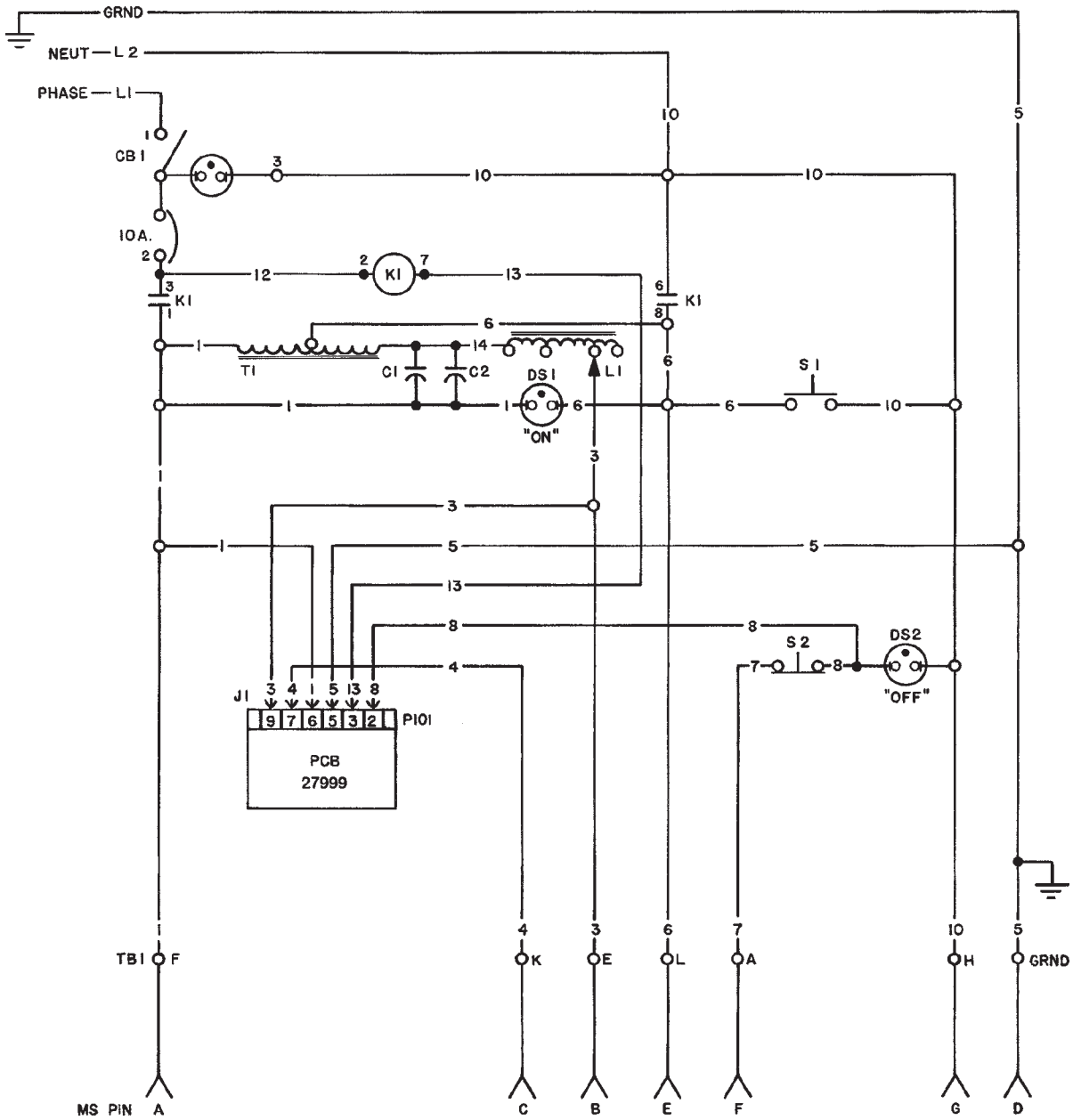

MS CONNECTOR

PIN	PIN
A - RED	E - WHITE
C - WHITE	F - WHITE
B - RED	G - WHITE
	D - GREEN



Relay Wiring,  
 27000 Power Supply  
 (Bottom View)

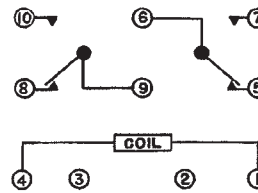
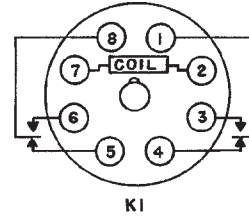

K102, K103

Printed Circuit Board  
 27000 Power Supply  
 Assembly 27999

- C103,104 Capacitor, 1.0  $\mu$ f, 600 W VDC
- C105,106 Capacitor, .01 $\mu$ f, 1000 W VDC
- C107 Capacitor, .01 $\mu$ f, 1000 W VDC
- C108 Capacitor, 150  $\mu$ f, 25 W VDC
- CR101 Bridge Rectifier, 1 A, 50 V.
- CR102,103 Zener Diode, 12 mA 110 V.
- K102 Relay, P&B R10-E1-X2
- K103 Relay, P&B R10-E1-Y2-J5.OK
- Relay Socket, P&B 27E128
- R101 Resistor, 27 Ohm, 5 $\frac{1}{4}$  W.
- R102 Resistor, 62k Ohm, 1 W.

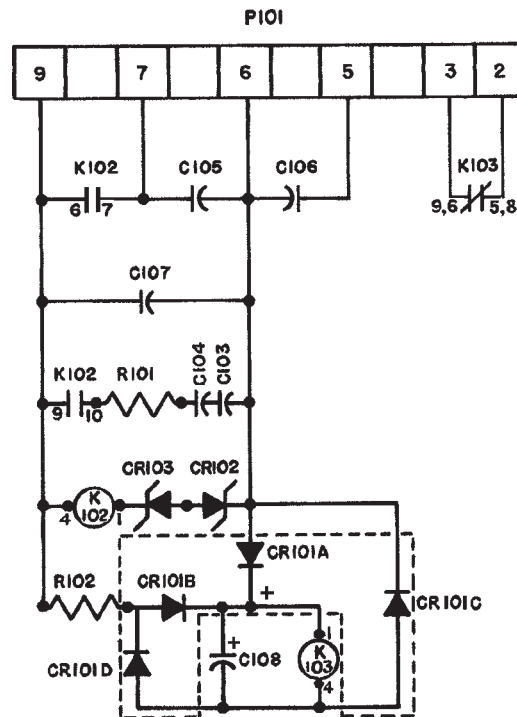

HMI POWER SUPPLY  
 Equipment Type 41106  
 December 1979 - July 1982

SUGGESTED WIRING OF LAMPHOUSE

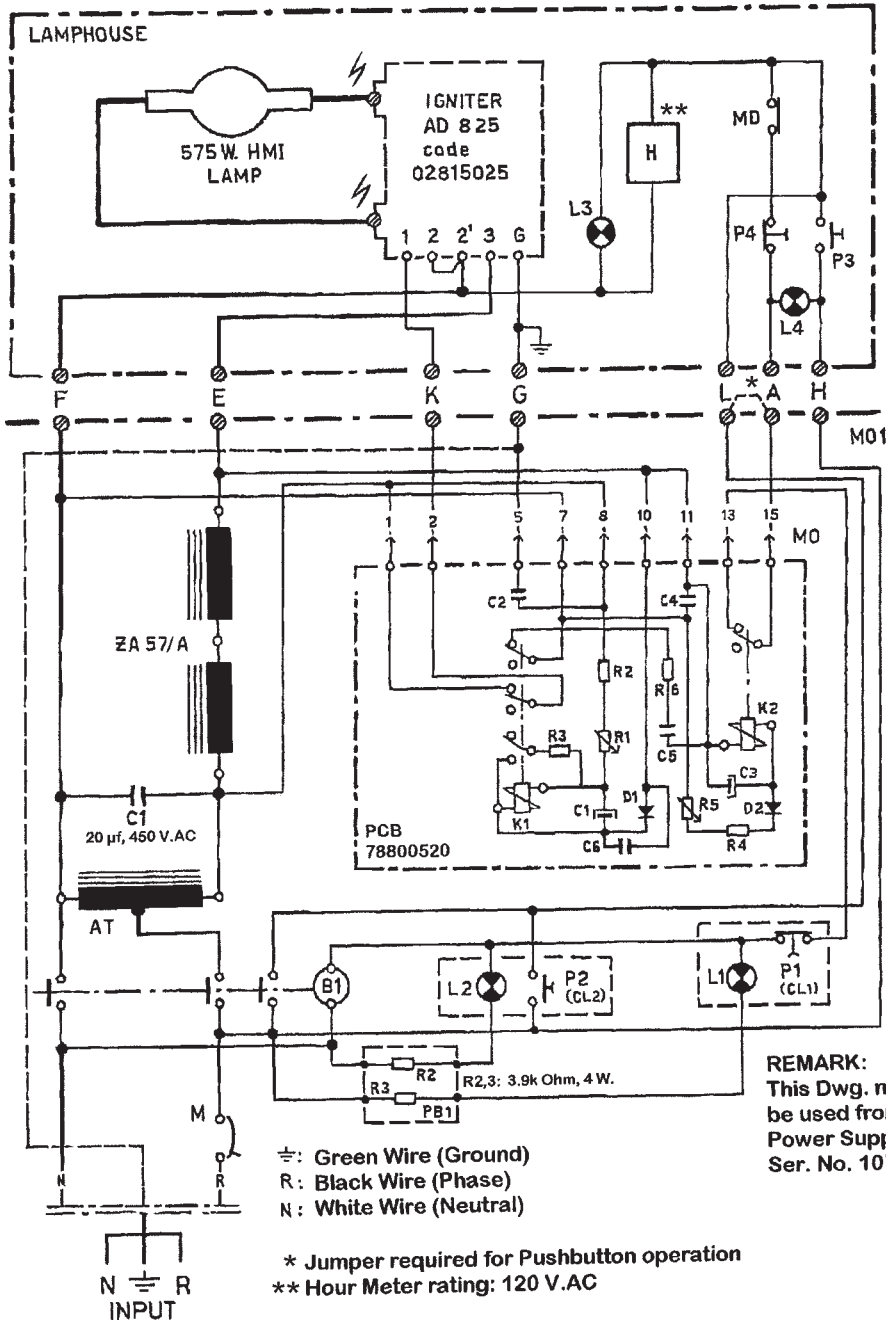

**IREM SpA**  
 Via Abegg 75  
 10050 Borgone (To) ITALY  
 Tel. +39 011 9649213  
 Fax +39 011 9646385



