

INSTRUCTION MANUAL

TROUPERETTE IV

Follow Spotlight

Type 45004-1,2

Rev. April 2005



STRONG INTERNATIONAL

a division of Ballantyne of Omaha, Inc.

4350 McKinley Street

Omaha, Nebraska 68112 USA

Tel 402/453-4444 • Fax 402/453-7238

www.strongint.com

FIGURE 1

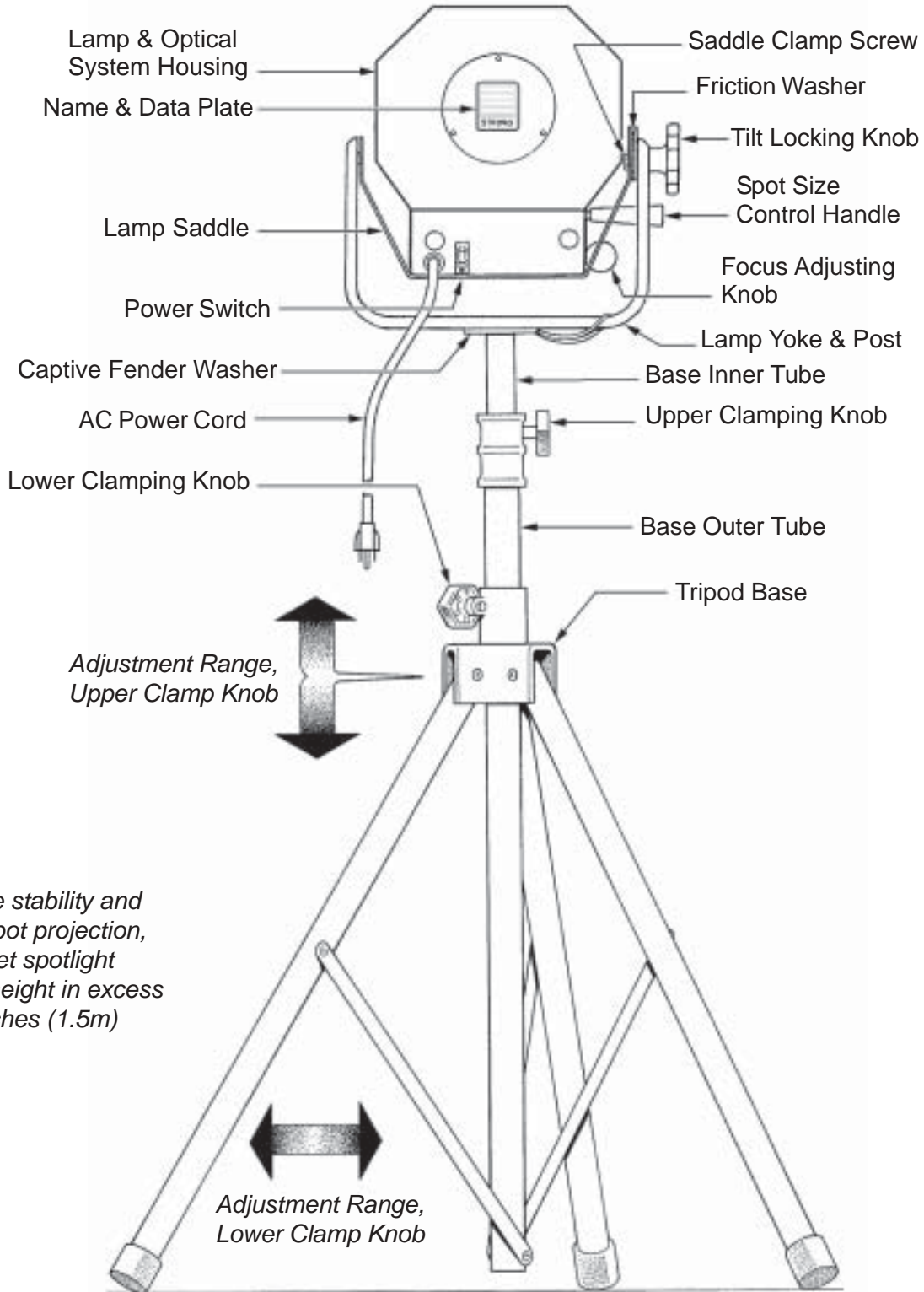

For base stability and stable spot projection, do not set spotlight overall height in excess of 58 inches (1.5m)

TROUPERETTE IV

TROUPERETTE IV Spotlight Set-Up

UNFOLD THE TRIPOD BASE and secure the legs by tightening the lower clamping knob. Loosen the upper clamping knob and withdraw a length of the base inner tube as shown; tighten the upper clamping knob. Insert the post of the yoke assembly into the base inner tube, placing the captive fender washer between the base inner tube and the bottom of the yoke as shown.

TIGHTEN THE CLAMPING KNOBS to secure the height adjustment. Mount the spotlight head to the lamp yoke by lowering the lamp saddle into the slots provided. Make certain the leather friction washer disc is between the flat metal friction surfaces of the saddle and yoke. Clamp the spotlight head in a horizontal position by tightening the cast aluminum vertical tilt locking knob onto the saddle clamp screw.

TO SET THE DESIRED THE HEIGHT OF THE SPOTLIGHT, loosen the upper clamping knob and raise or lower the inner tube as desired. Additional adjustment is available by loosening the lower clamping knob and adjusting the spread of the tripod legs. The height range from floor to optical center is extensive, but allow enough spread of the legs to insure stability.

THE TROUPERETTE IV requires a 1000 watt, 120 volt Type FEL projection bulb for domestic (USA) operation. An export model (45004-02) is available, and uses a 1000 watt, 240 volt Type FEP bulb. The rated life of either bulb is 250 hours, and it is advisable to have a spare bulb available (FEL - Part No. 45246; FEP - Part No. 45272).

TO INSTALL THE BULB, dismount the rear cover (with Name & Data Plate) by removing the (3) socket head cap screws. See the Detail drawing on Figure 4. Loosen the two thumb screws (Item 11) enough to slide the support bracket and bulb socket (Items 13 & 14) through the rear opening and out of the lamphouse. *Do not alter the position of the stop plate (Item 5).* Grasp the bulb by its metal base and push it firmly into the center of the socket (Item 14). **CAUTION:** Avoid touching the bulb envelope; skin oils in fingerprints will etch the envelope and possibly shorten the expected bulb life. Remove any accidental fingermarks immediately using alcohol and a clean, soft cloth.

SLIDE THE ASSEMBLED BRACKET and bulb back onto the support (Figure 4, Item 12) up to and resting against the stop plate (Item 5). Tighten the two thumb screws (Item 11) to secure the bulb and bracket in position, and replace the rear cover plate.

CONNECT THE LEAD CORD PLUG to an AC receptacle of the correct voltage (see Equipment Data Plate; 45004-01 = 120 V.AC, 45004-02 = 240 V.AC). Turn the lamp ON by means of the power switch and inspect the projected spot. If the spot is not satisfactory, see the instructions following regarding Reflector & Bulb Adjustments.

WHEN MOVING THE SPOTLIGHT from one location to another, it is highly advisable to remove the bulb and pack it separately. The bulb filament is very fragile and susceptible to breakage from jars and shocks, particularly after prolonged operation.

OPERATION OF OPTICAL SYSTEM

THE SPOT SIZE CONTROL HANDLE (“trombone”) is located on the right-hand side of the spotlight housing just above the base pan. A variation of spot sizes in a ratio of 5:1 can be obtained with the movement of the Spot Size Control from one extreme to the other.

THE APERTURE SELECTOR (“iris”) is the front handle projecting through the top of the lamphouse cover plate casting. When this handle is to the left (viewing spotlight from the rear), the largest aperture is open. Smaller apertures are obtained as the handle is moved to the right.

THE SPOT FOCUSING CONTROL KNOB is located on the lower right side of the optical system base pan, toward the front of the unit. This control is used to adjust the optical system for the length of throw. A nominal (“average”) setting of this control can be made by positioning the aperture selector (iris) handle to the right, and sliding the spot size control (trombone) to the extreme front. Then rotate the knob until the sharpest white light is obtained on the projected spot. If the spotlight remains at a given throw point, the focus control can be set to best sharpen the edge of the projected spot.

MAXIMUM “FLOOD” SPOT is obtained by opening the aperture selector (iris) by moving its control handle to the left, and sliding the spot size control (trombone) to its extreme rear stop. If projecting a flood spot for a prolonged period, it may be desirable to adjust the focus control to sharpen the edge of the spot.

SMALLER SIZED SPOTS are projected as the spot size control (trombone) is moved forward. Most commonly used spot sizes (head-to-foot “body” spots) are produced with a large aperture (iris open) and a small spot (trombone forward).

FOR A “HEAD” SPOT, or any spot smaller than can be obtained with the spot size control (trombone) in the extreme forward position, shift the aperture selector handle toward the right to close the iris and project a smaller spot. The aperture selector handle should always be returned to its extreme left setting before the spot size control handle is again moved to project larger spots.

A “DIFFUSED” SPOT is projected by pulling the spot size control (trombone) back toward “flood” setting while closing the iris (aperture selector handle toward right). A “diffused” spot is a “soft” edged spot with low light intensity and is seldom required.

THE MASKING SHUTTER AND DOUSER HANDLE (“chopper”) is the rear lever projecting through the top of the lamphouse cover casting. The masking shutter (chopper) blades are operated by this lever to shape the projected spot to a rectangle, a light strip, or to douse the spot for blackout. When the masking shutter control lever is to the extreme right, the chopper blades are open, and a round spot is projected. Varying degrees of top-and-bottom masking, to complete douse (light cutoff), are obtained as the lever is moved to the left.

ANGULAR ADJUSTMENT OF MASKING SHUTTER BLADES

THE ANGULARITY of the masking shutter (chopper) blades can be adjusted to compensate for the horizontal projection angle, for example, if the spotlight is positioned to the left or right of center stage. Remove the spotlight housing to expose the optical system.

AN UNBALANCED CONDITION will occur when the housing is removed, so the vertical tilt locking knob should be tightened. Slide the large lens forward by moving the trombone handle to the extreme forward position; remove the spot size control handle. Unscrew the knobs from the iris and chopper levers. Remove all screws securing the housing to the base pan, and lift the housing from the base pan.

SEE THE DETAIL DRAWING on Figure 5. Loosen, but do not remove, the screws (Item 16) securing each of the chopper blades (Items 14 & 18). Angle the lower blade so that it lies parallel with the footlights, and tighten the lower screw. Operate the masking shutter lever to close the chopper blades, and cause the upper blade to align to the lower blade. Secure the upper blade by tightening its mounting screw. Check the setting by lighting the bulb and projecting a narrow strip spot to the stage. Replace the housing and controls.

OPERATION OF THE COLOR BOOMERANG

THE COLOR BOOMERANG (Figure 6) is equipped with six 3-1/2" color filter discs containing the following colors, in sequence, from rear to front: (1) Golden Amber, (2) Flesh Pink, (3) Daylight Blue, (4) Light Sky Blue, (5) Primary Blue, and (6) Scarlet Red. Additional colors are available from theatrical supply dealers; specify ROSCOLUX® (or equivalent) *high temperature* gels.

THE SIX COLOR DISC CONTROL LEVERS are mounted in the cover plate directly in front of the aperture selector (iris) lever. To insert a color disc into the light beam, move the desired disc lever to its extreme left position. To release a color, return the lever to the extreme right. Always operate the color levers to the limits of their travel.

TO DISMOUNT A COLOR DISC, unscrew the knobs on the iris and chopper levers and remove the four screws securing the top cover plate to the housing. Lifting the top cover plate from the spotlight will remove the boomerang assembly. Each color disc is mounted to its control arm by two screws. See Figure 6 Parts List for replacement discs.

HANDLING THE SPOTLIGHT

GENERALLY THE BEST POSITION FOR OPERATION is to stand near the center of the spotlight on the right-hand side. The angle of tilt and the size and location of the porthole may, however, alter the position for most convenient operation. One hand should be kept on the spot size control handle, as the spot can thus be directed and changed in size simultaneously. The other hand is normally used for operation of the optical system and boomerang control levers, and generally steadying the spotlight.

THE VERTICAL TILT LOCKING KNOB on the side of the lamp saddle can be tightened or loosened to provide the desired degree of friction to suit the individual operator. A brake screw on the outrider of the large lens carriage (Figure 3, Item 15) can also be set to provide more or less “drag” to the spot size control handle.

REPLACEMENT AND ADJUSTMENT OF REFLECTOR AND BULB

THE REFLECTOR has been carefully aligned at the factory for maximum light collection and transmission, and under normal circumstances, its position should not be changed. If it becomes necessary to replace the reflector, tighten the vertical tilt locking knob to immobilize the spotlight, unscrew the knobs from the iris and chopper control levers, remove the spot size control handle, and dismount the spotlight housing.

SEE THE DETAIL DRAWING on Figure 4. Dismount the reflector (Item 15) by removing *only* the reflector mounting screws (Item 2). *Do not remove plate mounting screws (Item 16) or otherwise alter the location of the mounting plate (Item 1)*. Install the replacement reflector (45245) without disturbing the position of the mounting plate.

IF THE ORIGINAL or a replacement bulb fails to produce a suitable spot, it may be (a) the bulb is not properly seated in its socket, or (b) because of manufacturing tolerances, the position of the bulb filament differs slightly from the bulb used prior. Project a spot with the iris open and the spot size control handle about five inches back from the front of the lamphouse. Rotate the focus knob to obtain the sharpest possible spot.

IF A DARK AREA APPEARS at the top or bottom of the spot, slightly loosen the two screws (Figure 4, Item 8) and move the bracket (Item 12) up or down on its slots to obtain even illumination. When corrected, tighten the two bracket mounting screws.

IF THE CENTER OF THE SPOT appears darker or brighter than the edges, loosen the two thumb screws (Figure 4, Item 11) and move the bracket (Item 13) slightly to the rear of the lamp-house. If this does not balance the light, the stop plate (Item 5) must be moved a little toward the front of the bracket (Item 12). Loosen the screws (Item 6) just enough to move the stop plate (Item 5) in small increments until an even spot is projected. When a satisfactory spot is obtained, tighten all fasteners securely.

MAINTENANCE

TROUPERETTE LENSES SHOULD BE CLEANED with a liquid lens cleaner formulated for use with coated lenses, and lens tissue. These items are available from theatrical or motion picture supply dealers. A good grade of alcohol and facial tissue may be substituted. *Do not use abrasive cleansers of any kind.*

TO CLEAN THE SMALL LENS, remove the slotted top cover plate and boomerang to access the rear lens carriage. The back surface of the large lens can also be cleaned through this opening when the spot size control handle is moved to its extreme rear position. Returning the trombone handle to its front position allows the front surface of the large lens to be cleaned through the front opening of the spotlight housing.

THE INTAKE GRILLE of the fan should be cleaned regularly to prevent dust build-up, which could restrict air flow. A reduction in forced-air cooling will greatly shorten the life of the FEL or FEP bulb; replace the fan if defective. The fan motor incorporates sealed bearings and requires no lubrication.

PARTS LISTS
Troupurette IV
Type 45004

FIGURE 2	Floor Stand & Yoke
FIGURE 3	Base Pan & Lens Mechanism
FIGURE 4	Bulb & Reflector Mount
FIGURE 5	Optical System
FIGURE 6	Color Boomerang

Replacement Parts for Strong Troupurette IV Follow Spotlights are available through authorized Strong International Dealers *only*. Order by Part Number and Description.

Goods returned to Strong International must be marked with a **Return Authorization** number issued by Strong to its Dealer prior to shipment. Return freight must be prepaid.

FIGURE 2

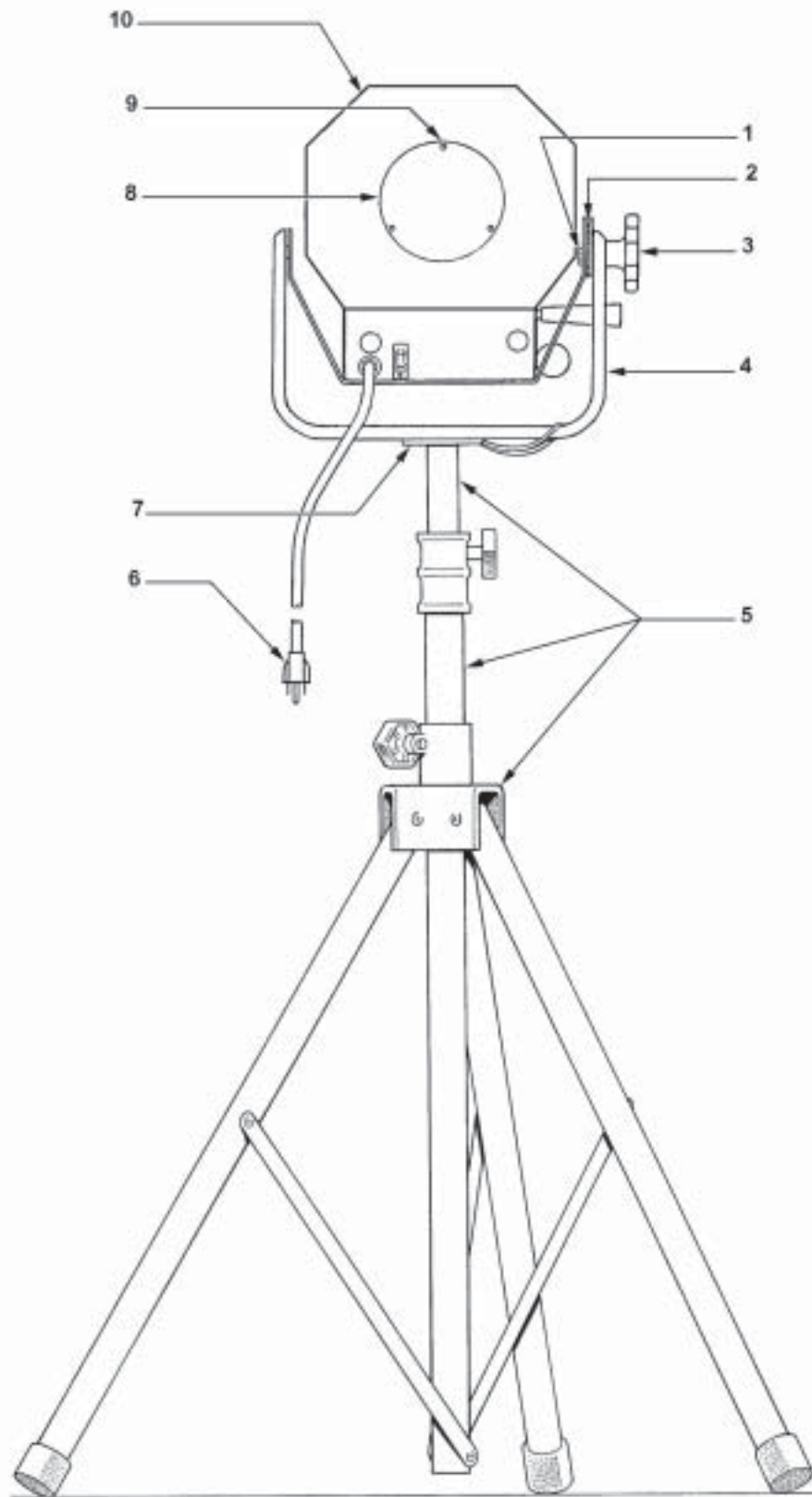

PARTS SHOWN ON ILLUSTRATIONS

<u>Figure</u>	<u>Item</u>	<u>Part No.</u>	<u>Description</u>
2	1	45152	Screw, Saddle Clamp
	2	45151	Friction Washer, Leather
	3	45153	Vertical Tilt Locking Knob, Cast
	4	45987	Yoke & Post, Welded Assembly
	5	72-00634	Trouperette Tripod Base Assembly
	5	72-00737	Tripod Base with Casters (not shown)
	-	34014	Caster (not shown)
	6	45918	AC Power Cord with Molded Plug, 120 V.AC
	-	49295	Plug, 230 V.AC (Export)
	7	72-00633	Fender Washer
-	31-98178	Lanyard	
8	72-00739	Back Cover Plate	
9	4100500	Mounting Screw, 10-32 x 1/2" Socket Head	
-	4107101	Flatwasher, #10	
-	4108021	Tinnerman Nut, #10	
10	72-00216	Spotlight Housing, Welded Assembly (see Figure 3, Item 21)	

<u>Figure</u>	<u>Item</u>	<u>Part No.</u>	<u>Description</u>
3	1	4080310	Screw, 8-32 x 5/16" Pan Head
	-	4087000	Lockwasher, #8 Split Ring
	2	51493	Ring, Large Lens Carriage
	3	51492	Rubber Edge Mounting
	4	45209	"E" Ring, 3/16"
	5	4107101	Flatwasher, #10
	6	51133	Lens Focus Adjusting Block
	7	45208	Shaft, Focus Adjusting
	8	51114	Stop Collar, Slide Rod
	-	4100252	Set Screw, 10-32 x 1/4" Cup Point
	9	48103	Knob, Focus Adjust
	10	4060250	Screw, 6-32 x 1/4" Pan Head
	-	4067001	Lockwasher, #6 Shakeproof
	11	45224	Stud, Lens Focus
	-	4250508	Screw, 1/4-20 x 1/2" Pan Head
	12	51992	Focus Ribbon, Welded Assembly
	13	51509	Handle, Red Plastic
-	51508	Shaft, Spot Size Control (Trombone)	
-	4378001	Hexnut, 3/8-16	
14	51158	Lens Ribbon Pulley, Small	
-	51160	Pulley Stud	
15	4251001	Screw, Lens Friction Brake; 1/4-20 x 1" Hex Head (Nylon)	
-	4258015	Lock Nut, Friction Brake; 1/4-20 Hex (Nylon)	
16	51162	Expansion Spring, Lens Ribbon	
17	45945	Base Pan & Saddle, Welded Assembly	

FIGURE 3

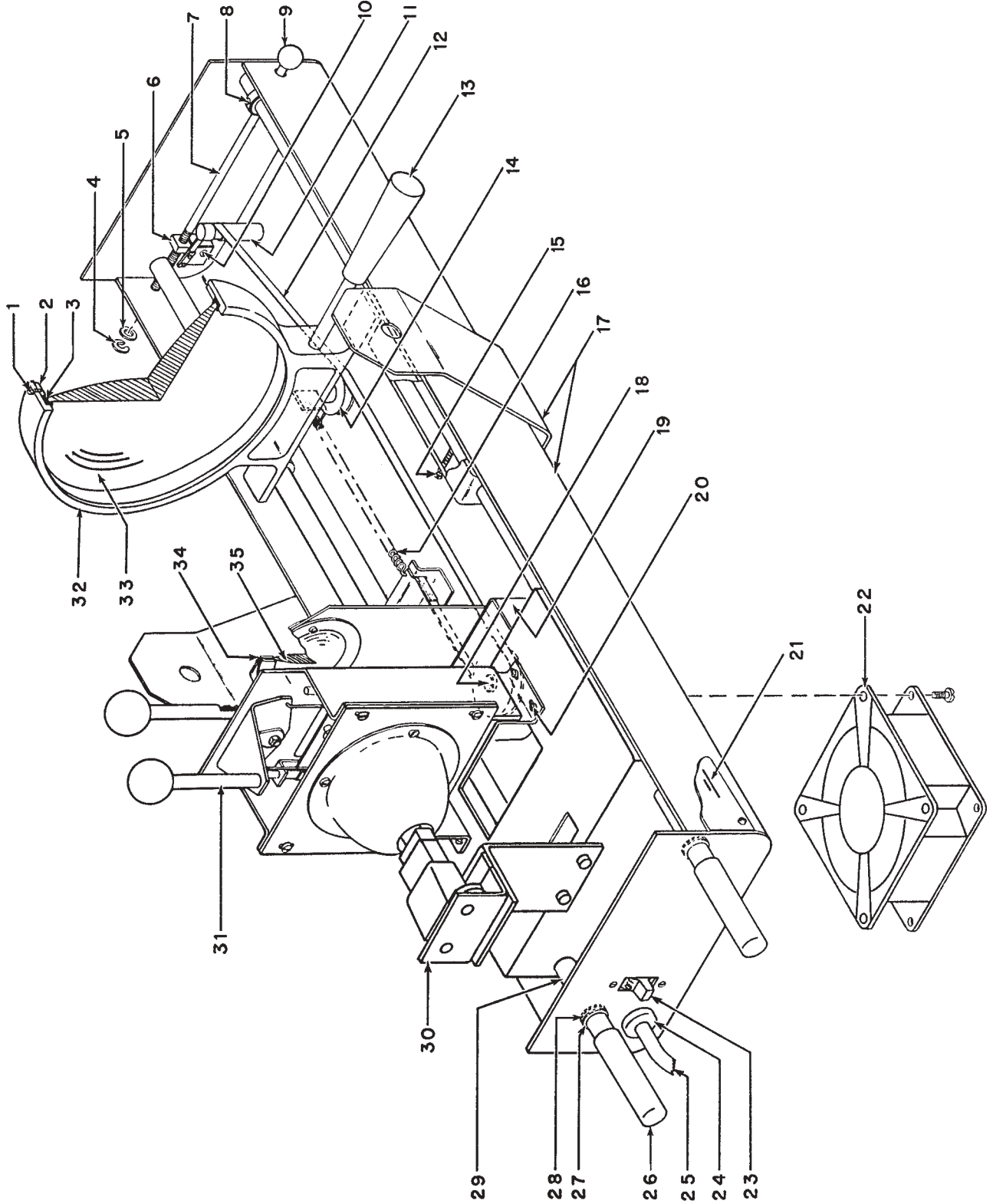

<u>Figure</u>	<u>Item</u>	<u>Part No.</u>	<u>Description</u>
3	18	51157	Lens Ribbon Pulley, Large
(Con'd)	-	51160	Pulley Stud
	-	4087100	Spacer Washer, #8 Flat
	19	45930	Small Lens Carriage, Welded Assembly
	20	4100500	Screw, 10-32 x 1/2" Socket Head
	-	45258	Shim (below Aperture Support)
	21	72-00216	Spotlight Housing, Welded Assembly (see Figure 2, Item 18)
	-	4100250	Mounting Screw, 10-32 x 1/4" Binding Head
	22	61-98002	Fan, 4" Square Frame, 120 V.AC, 50/60 Hz.
	-	81272	Fan, 4" Square Frame, 240 V.AC, 50/60 Hz. (Export)
	-	72-00546	Blower Mounting Plate (not shown)
	-	88253	Cord & Plug, Fan
	-	83131	Inlet Grille, Plastic (Fan Guard)
	-	4062000	Fan Mounting Screw, 6-32 x 2" Socket Head
	-	4067001	Lockwasher, #6 Shakeproof
	23	45331	Switch, Power ON - OFF, 120 V.AC (Domestic)
	-	45281	Switch, Power ON - OFF, 240 V.AC (Export)
	24	23163	Strain Relief Bushing
	25	45918	AC Power Cord with Molded Plug, 120 V.AC
	—	49295	Plug, 230 V.AC (Export)
	26	45150A	Handle Grip, Plastic
	27	91219	"E" Ring, 5/8" Flat
	28	46137	"E" Ring, 5/8" Bowed
	29	45278	Slide Rod (Left & Right)
	30	-	See Figure 4
	31	-	See Figure 5
	32	51856	Large Lens Carriage Casting
	33	51102	Large Lens, 7" Diameter
	34	45254	Lens Retaining Ring
	-	4060250	Screw, 6-32 x 1/4" Fillister Head
	-	4068001	Hexnut, 6-32
	-	4067001	Lockwasher, #6 Shakeproof
	35	45252	Small Lens, 2.5" Diameter

<u>Figure</u>	<u>Item</u>	<u>Part No.</u>	<u>Description</u>
4	1	45250	Mounting Plate, Reflector
	2	4060376	Sheet Metal Screw, 6-32 x 3/8" Hex Head
	3	45246	Tungsten-Halogen Bulb, 1000 Watt, Type FEL (Domestic)
	-	45272	Tungsten-Halogen Bulb, 1000 Watt, Type FEP (Export)
	4	4080375	Screw, 8-32 x 3/8" Pan Head
	5	45261	Stop Plate, Bulb Bracket
	6	4110500	Screw, 10-24 x 1/2" Socket Head
	-	4107101	Flatwasher, #10
	-	4107001	Lockwasher, #10 Shakeproof
	7	45275	Lamphouse Support Bracket
	8	4110500	Screw, 10-32 x 1/2" Socket Head

FIGURE 4

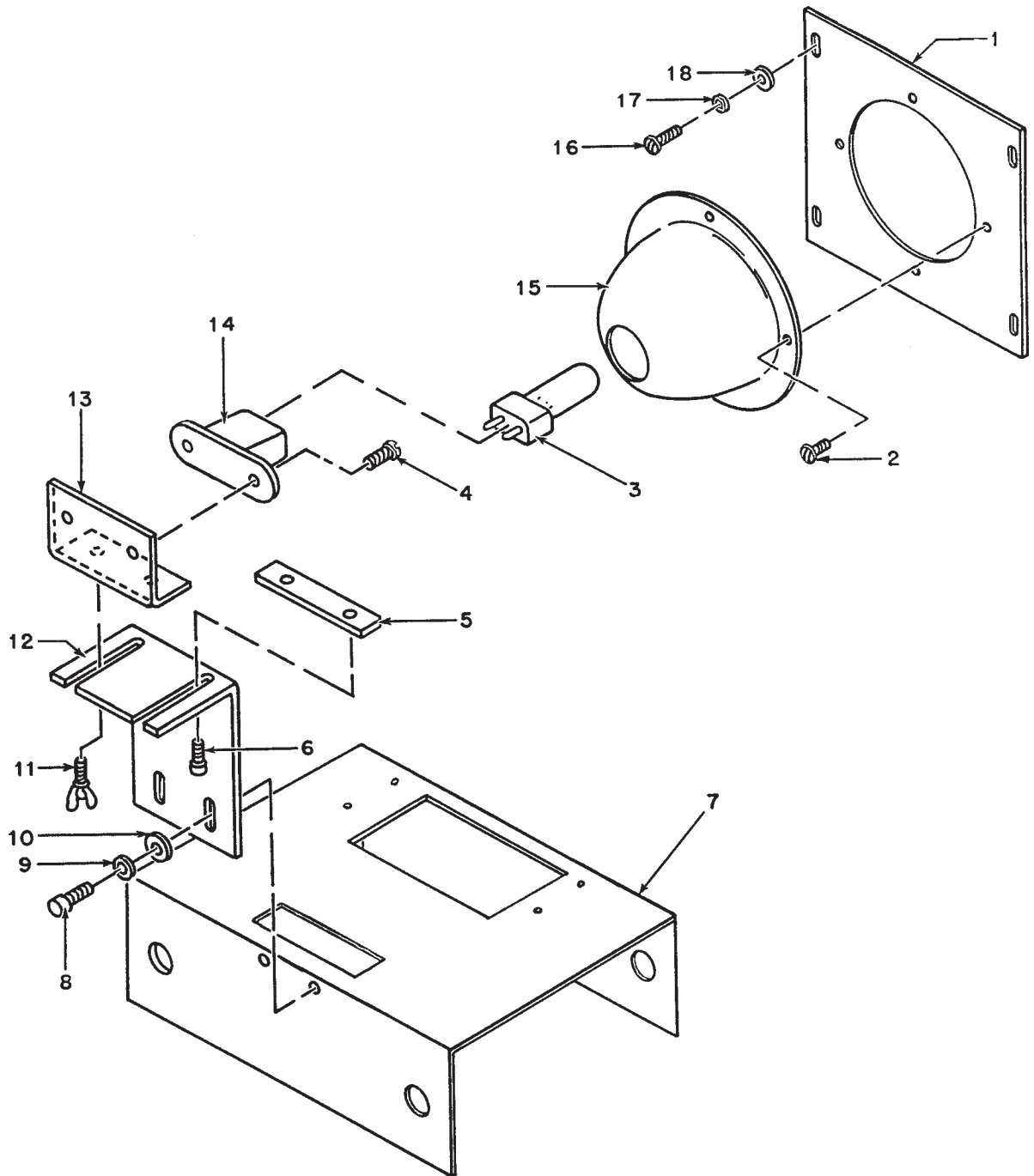
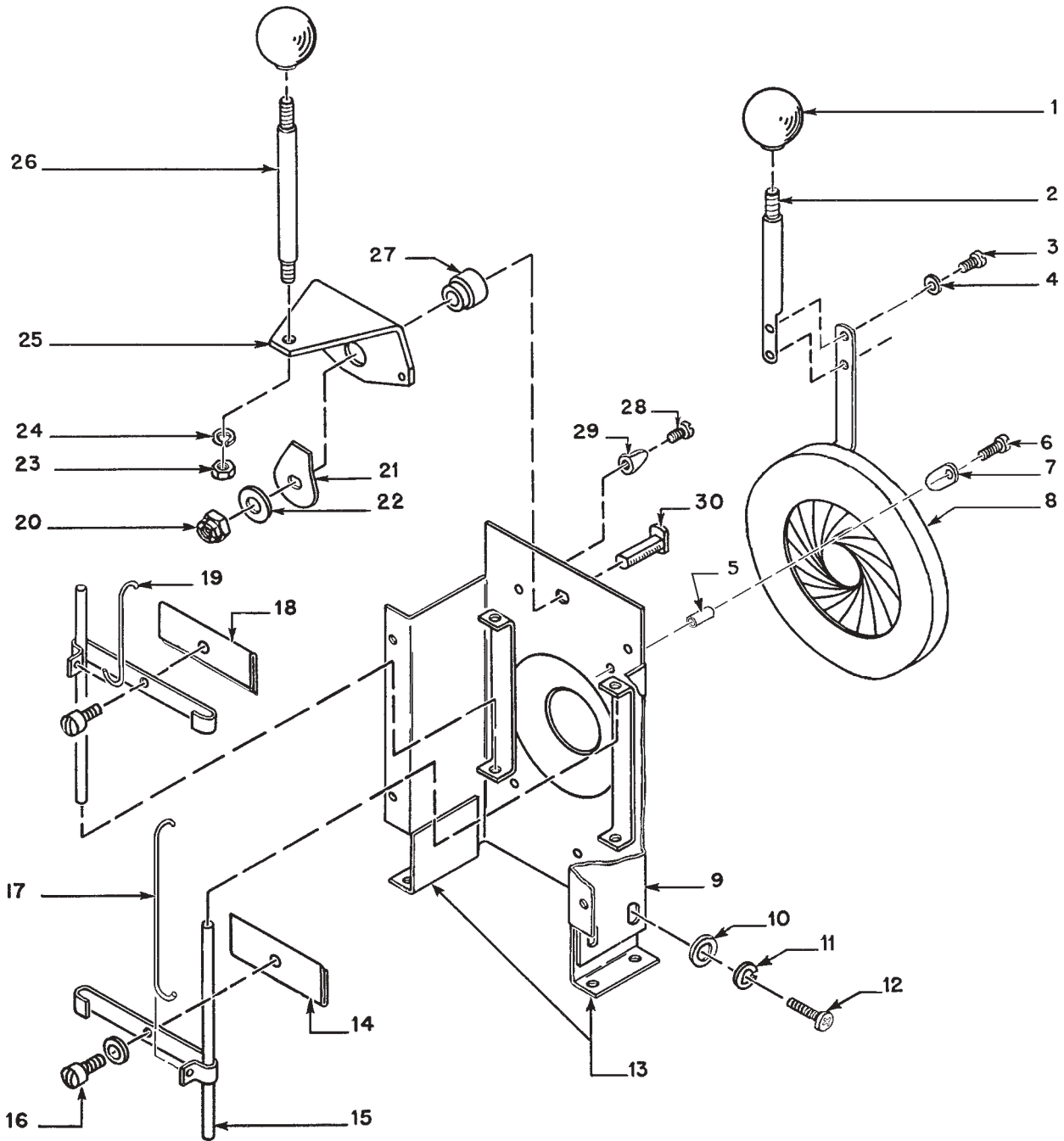

FIGURE 5



<u>Figure</u>	<u>Item</u>	<u>Part No.</u>	<u>Description</u>
4	9	4107001	Lockwasher, #10 Shakeproof
(Con'd.)	10	4107101	Flatwasher, #10
	11	4110373	Thumb Screw, 10-24 x 3/8"
	12	45263	Support Bracket, Slotted
	13	45262	Bracket, Bulb Socket
	14	45247	Socket, 120/240 Volt, FEL/FEP
	15	45245	Reflector
	16	4080375	Screw, 8-32 x 3/8" Pan Head
	17	4087000	Lockwasher, #8 Split Ring
	18	4087101	Flatwasher, #8

<u>Figure</u>	<u>Item</u>	<u>Part No.</u>	<u>Description</u>
5	1	10048A	Knob, Red Plastic
	2	51228	Shaft, Iris Control
	3	4060370	Screw, 6-32 x 3/8" Pan Head (2 req'd.)
	4	4067001	Lockwasher, #6 Shakeproof (2 req'd.)
	5	72-00844	Iris Clamp Spacer (3 req'd.)
	6	4080754	Screw, 8-32 x 3/4" Pan Head (3 req'd.)
	7	4258091	Weld Nut (3 req'd.)
	8	72-00548	Iris Assembly
	-	4067101	Spacer Washer (not shown)
	9	45925	Aperture Support Bracket, Welded Assembly
	10	4107101	Flatwasher, #10
	11	4107000	Lockwasher, #10 Split Ring (as req'd.)
	12	4100371	Screw, 10-32 x 3/8" Pan Head
	13	45924	Mounting Bracket, Aperture Support (Left & Right)
	14	47978	Chopper Blade, Lower
	15	47982	Slide Assembly (Upper & Lower)
	-	47972	Lower Blade & Slide Assembly (Items 14 & 15)
	16	4080181	Screw, 8-32 x 3/16" Pan Head (41-51318)
	-	4087000	Lockwasher, #8 Split Ring
	17	51497	Pull Rod, Long
	18	47979	Chopper Blade, Upper
	-	47973	Upper Blade & Slide Assembly
	19	51498	Pull Rod, Short
	20	4318004	Nut, 5/16-18 FlexLock
	21	51156	Friction Plate (older models; replace with 4507106)
	21	4507106	Friction Washer (current production)
	22	4317100	Flatwasher, 5/16"
	23	4258001	Hexnut, 1/4-20
	24	4257000	Lockwasher, 1/4" Split Ring
	25	51488	Bracket, Masking Control
	26	51155	Operating Shaft, Masking Control

FIGURE 6

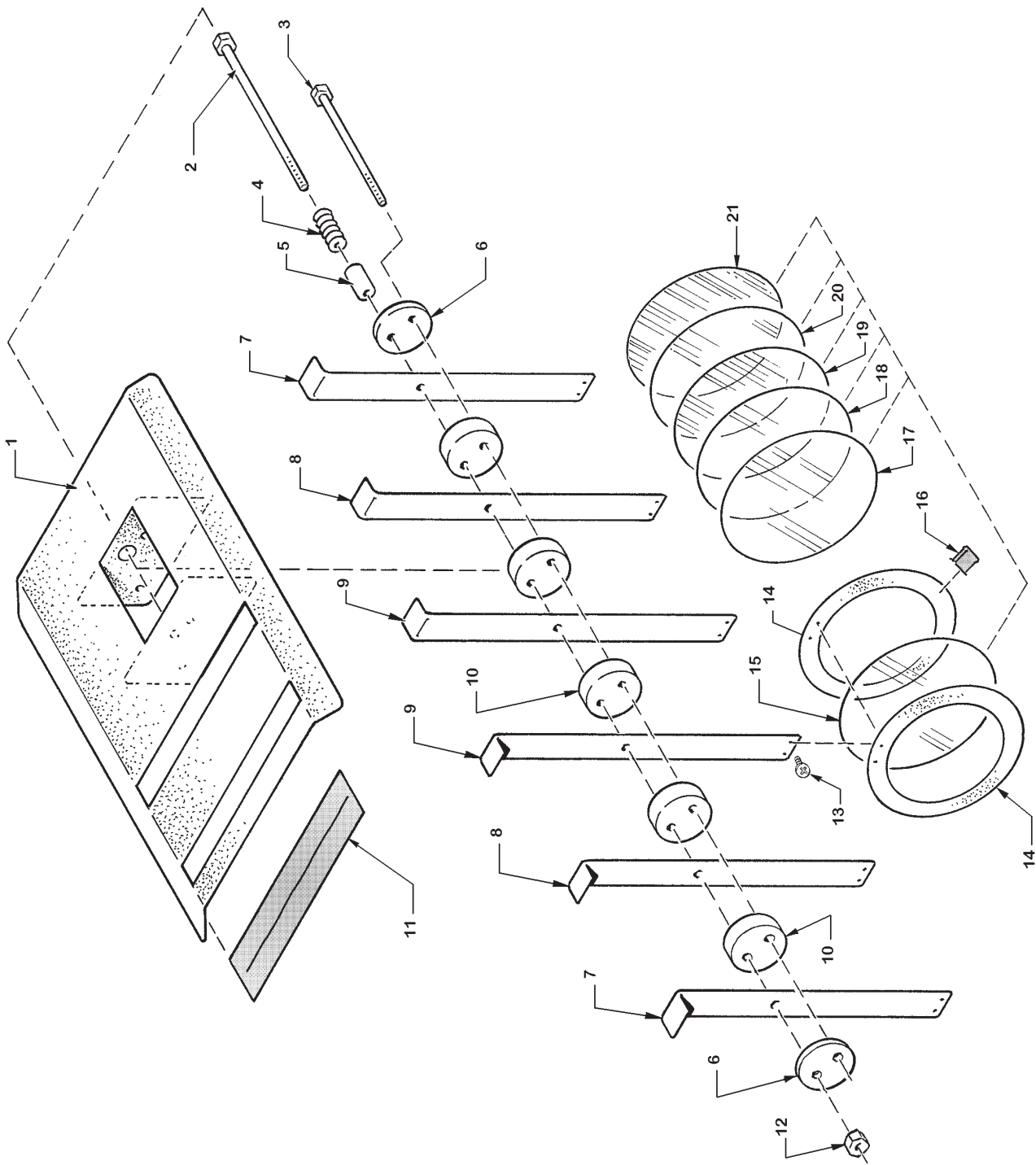

<u>Figure</u>	<u>Item</u>	<u>Part No.</u>	<u>Description</u>
5	27	51153	Spacer Bushing
(Con'd.)	28	4080250	Screw, 8-32 x 1/4" Pan Head
	29	47170	Iris Stop
	30	51226	Stud, Masking Control Bracket

<u>Figure</u>	<u>Item</u>	<u>Part No.</u>	<u>Description</u>
6	1	72-00218	Boomerang Cover Plate, Welded Assembly
	2	4254000	Pivot Bolt, 1/4-20 x 4" Hex Head
	3	4253500	Stop Bolt, 1/4-20 x 3-1/2" Hex Head
	4	01026	Compression Spring
	5	45135	Pivot Bolt Bushing
	6	45133	Spacer, Nylon (Thin)
	7	45129	Color Disc Handle, Short
	8	45130	Color Disc Handle, Intermediate
	9	45130	Color Disc Handle, Long
	10	45134	Spacer, Nylon (5 req'd.)
	11	51371	Rubber Light Gasket (Order by foot)
	12	4258015	Hexnut, 1/4-20 Nylon (4 req'd.)
	-	4257001	Lockwasher, 1/4"
	13	4060180	Screw, 6-32 x 3/16" Pan Head (6 req'd.)
	14	45122	Color Frame, 3-1/2"
	15	45986	Color Disc Assembly, Golden Amber (with Items 14 & 16)
	16	46150	Clip, Color Frame (2 per frame pair)
	17	45985	Color Disc Assembly, Flesh Pink (Items 14 & 16 not shown)
	18	45984	Color Disc Assembly, Daylight Blue (Items 14 & 16 not shown)
	19	45983	Color Disc Assembly, Light Sky Blue (Items 14 & 16 not shown)
	20	45982	Color Disc Assembly, Primary Blue (Items 14 & 16 not shown)
	21	45981	Color Disc Assembly, Scarlet Red (Items 14 & 16 not shown)
	-	41944	Color Disc Assemblies, set of Six
	-	72-00217	Color Boomerang Assembly (Figure 6, Items 1 - 21 Complete)
	-	4080375	Boomerang Mounting Screws, 8-32 x 3/8" (4 req'd.)
	-	4087101	Flatwasher, #8 (4 req'd.)

Theatrical Supply Dealers generally stock a complete selection of color media, including color correction filters (required for television & videotaping). Specify ROSCOLUX® or equivalent **high temperature** gels.

Install darker gels (red, green, dark blue) toward the *front* of the boomerang (**away** from the bulb) and gels of lower density (pink, amber, and lighter colors) at the *rear* positions.

