

INSTRUCTION MANUAL

TrussTrouper 1.2

Follow Spotlight

Equipment Type 41080

Issue 10/99



STRONG INTERNATIONAL

a division of Ballantyne of Omaha, Inc.

4350 McKinley Street

Omaha, Nebraska 68112 USA

Tel 402/453-4444 • Fax 402/453-7238

PREFACE

THE STRONG TrussTrouper 1.2 Type 41080 is a high intensity, lightweight follow spotlight designed for high performance and ease of operation and portability. The light source is an OSRAM 1200 watt HMI Metal Halide bulb mounted transversely in a fixed, deep ellipse type metal reflector. The bulb is warranted for (500) hours of operation, and it is advisable to have a spare bulb available for each unit.

THE SPOTLIGHT is shipped with a yoke adaptable for truss mounting. An optional folding floor stand assembly, and overhead Hanger Kit, are available from Strong International. Lens mechanisms are available in Long, Medium and Short throw configurations, and are readily mounted to the TrussTrouper as the application or venue require.

THE SOLID STATE POWER SUPPLY is mounted below the head assembly. The power supply and lamphouse are forced-air cooled by built-in blowers. Lamphouse and power supply are controlled by means of fixture-mounted pushbutton switches at the rear of the base pan.

POWER REQUIREMENT for the TrussTrouper is 120 V.AC, 15 amperes, 60 Hertz. Approximate line draw is 12 amperes. A 220 V.AC, 50/60 Hertz model is available under Type Number 41080-03 or -04. A 12 foot, three-wire power cord is mounted to the power supply.

THE OPTICAL SYSTEM, designed for left- or right-hand operation, includes a variable focus lens mechanism which intensifies light output as the spot size is reduced from flood to spot. The (2) rear mounted controls operate the fade out/douser and the iris. Control levers for the six color self-cancelling boomerang are located on the top of the housing. A pattern slot for gobos is accessible in front of the iris.

REPLACEMENT BULBS are available through authorized Strong International and OSRAM Dealers. Use only the OSRAM 1200W HMI in this unit. Bulbs returned for warranty adjustment must be returned through the original supplier, shipped prepaid, with all relevant warranty papers completed and enclosed.

IF AT ANY TIME you have a suggestion, or desire aid in securing anticipated results, write directly to STRONG INTERNATIONAL, 4350 McKinley Street, Omaha, Nebraska 68112.

INSTALLATION - OPERATION

INSPECT THE UNIT upon receipt. Any damage must be reported to the freight carrier immediately. It is the responsibility of the *consignee*, not the shipper, to file damage claims.

THE HMI BULB is included in the accessory kit packed with the spotlight. DO NOT touch the quartz envelope when handling the bulb; fingermarks will burn into the vessel, reducing light, and contributing to premature bulb failure. Handle the bulb by the metal base caps *only*. The HMI bulb is *not* polarized, and the igniter lead can attach to either end.

DISMOUNT THE LAMPHOUSE COVER from the rear of the lamphouse by loosening the (4) captive screws. Loosen the top bulb mounting bracket and remove the threaded nuts from the ends of the HMI bulb. Pull the upper bulb mount clear of the reflector and insert the bulb through the reflector holes. Slide the lower bulb end cap through the lower mounting opening; attach the igniter lead and secure using the knurled nut. Swing the top bulb mounting bracket over the upper end cap; attach the upper lead, and secure using the knurled nut. Tighten the top mounting bracket.

IF USING THE OPTIONAL FLOOR STAND ASSEMBLY, drop the legs to the horizontal position and pin in place. The floor stand may then be moved on its casters to desired location. IMPORTANT: Once the floor stand has been positioned, lower the leveling feet to transfer the weight of the unit from the casters to the leveling feet. If the unit is to be permanently installed, it is advisable to remove both casters and leveling feet, and bolt the stand to the floor.

INSERT THE POST of the yoke assembly into the nylon bushing at the top of the floor stand tube. Position the yoke for right- or left-hand operation (as desired). Place the spotlight head on the yoke assembly, making certain that the friction plate of the spotlight saddle is between the yoke and the brake clamping plate. Tighten the (2) handwheel knobs on each side of the yoke allowing adequate end play for free operation, and tighten the (2) lock knobs. Vertical movement of the spotlight head can be adjusted by the amount of torque applied to the spring-loaded clamping knob against the friction plate.

SET THE BALANCE of the head assembly. Loosen the (2) hex nuts on each side securing the saddle brackets to the spotlight base rail. Slide the spotlight head inside the slots until the proper balance is achieved, and retighten the hex nuts.

THE SPOTLIGHT YOKE, as supplied, is designed for use with standard truss fixtures. Truss mounting the TrussTrouper will depend largely on its application in any given venue.

THE TRUSSTROUPER SPOTLIGHT may be suspended from a ceiling or overhead truss by means of an optional Hanger Kit. This kit is available through your authorized Strong International Dealer.

ELECTRICAL CONNECTION for the 41080-01 or -02 (120 V.AC, 60 Hz.) requires a 120 V.AC, three prong 15 ampere grounded outlet. The Type 41080-03 or -04 (240 V.AC, 50/60 Hz.) may be fitted with a plug acceptable for the local electrical supply. Cooling fans are either 120 V.AC or 240 V.AC and not interchangeable; see Data Plate on unit for correct voltage. Sustaining line draw of the TrussTroupier is (12) amperes; observe local electrical codes.

ENERGIZE THE AC LINE as required. When the power switch at the rear of the spotlight head is closed, the bulb will ignite, and the cooling fans will operate. Allow one to five minutes for the bulb to reach full intensity. Rotate the three adjusting screws below the lamphouse base pan to center and focus the bulb inside the reflector. Alternate adjustments until the light field is as flat as possible at highest intensity.

WHENEVER THE SPOTLIGHT is moved, either from one position to another, or one show site to another, the bulb mount should be inspected at the new installation site to determine that the bulb is firmly seated in its socket. The above bulb alignment procedure must then be repeated after the bulb mount assembly is replaced.

MAINTENANCE

THE TrussTroupier requires very little maintenance to keep it in good working order. Cleanliness is the most important factor. Clean the surface of the reflector regularly using a clean, dry cloth. If excessively soiled, a good, spray-on commercial glass cleaner may be used. The bulb envelope may be cleaned with alcohol, and rinsed with distilled water on a clean cloth.

THE COOLING FANS are permanently lubricated, and require no oil. Fan impeller blades and intake grilles must be cleaned regularly to prevent restriction of air flow, particularly after events such as tractor pulls or rodeos.

OPTICAL SYSTEM LENSES may be cleaned with an optical grade lens cleaner and Roscoe Lens Tissue. Light lubrication of the lens carriage slide rods using WD-40® or equivalent may be desirable; do not use graphite lubricants, and do not lubricate the iris assembly.

OPERATION OF OPTICAL SYSTEM

THE OPTICAL SYSTEM of the TrussTrouper consists of a spot size selector, an iris assembly to reduce the size of the spot aperture, and a fade-out chopper assembly to permit reducing light output from full intensity to complete douse. The iris and chopper controls are mounted on the back of the lamphouse and are fully accessible from either side of the unit. The spot size is selected by setting and locking a control knob located on the right side (as viewed from rear) of the unit.

INSTALL A LENS MECHANISM compatible with the desired throw. The three lens mechanisms are designated as Short, Medium, and Long Throw. The throw specifications listed below may serve as a guideline when first setting up the TrussTrouper, but optimal performance at a given throw distance may vary with ambient light levels, projection angles, and other variables unique to the venue.

Short Throw	20 - 50 feet (6.0 - 15.2 m)
Medium Throw	40-100 feet (12.2 - 30.5 m)
Long Throw	50-130 feet (15.2 - 39.6 m)

IGNITE THE LAMPHOUSE and allow the bulb to stabilize. Open the iris to project the largest aperture by rotating the iris control (left) fully counterclockwise. Open the chopper blades by rotating the chopper control (right) fully clockwise. Rotate the spot size control knob (right side) counterclockwise to unlock, and slide the knob forward or back to set the desired spot size. Lock the spot size control at the desired point.

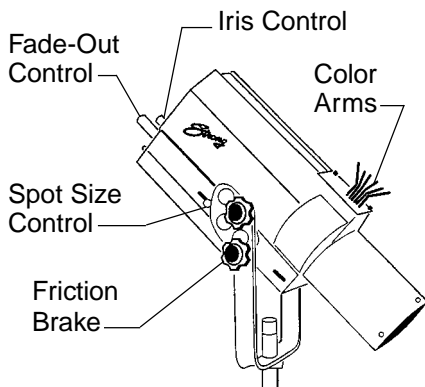

TO REDUCE SPOT SIZE, or to project a “head” spot, rotate the iris control clockwise to the desired spot size. The spot cannot be doused by means of the iris control; do not force the control beyond its stop.

ROTATING THE FADE-OUT CONTROL will decrease the light output, and dim the spot to complete douse-out. It is advisable to use the dousing capability of this control to cut off the light between cues instead of extinguishing the bulb. The HMI bulb requires a relatively long warmup period, and repeated ignitions decrease bulb life.

OPERATION OF COLOR BOOMERANG

THE COLOR BOOMERANG is equipped with six color holders. Additional filter holders can be supplied by an authorized Strong International Dealer.

TO OPERATE INDIVIDUAL COLOR FILTERS, engage the desired filter selector lever. A rocker catch located in the color disc housing holds the filter in position.

TO RELEASE A COLOR, push the filter release button or engage another color, thus releasing the previous color automatically.

NOTE: WHEN PLACING COLOR FILTERS in the boomerang, the *less* dense colors (pink, amber) should be placed in the holders toward the **rear** of the boomerang (toward arc), and those of *greater* density (red, green) should be placed in the holders toward the **front** of the boomerang (away from the arc). Use *high temperature* filter material (RoscoLux[®] or equivalent).

COLOR TEMPERATURE REDUCTION FILTERS, required for use with television and videotape, are available from theatrical supply dealers.

TrussTrouper 1.2 Wiring Diagram

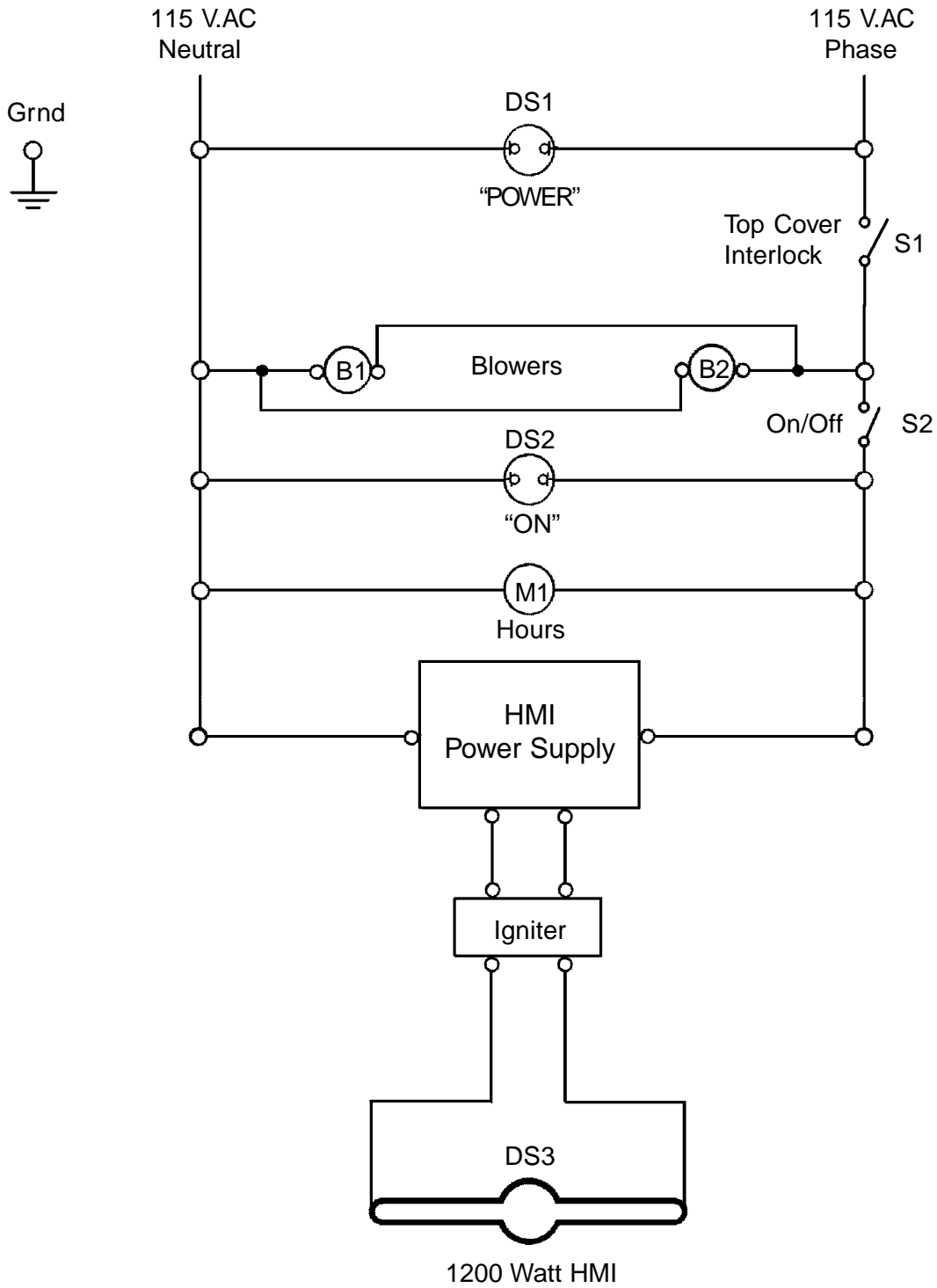

WIRING DIAGRAM

Parts List

Ref.	Desig.	Part No.	Description
	B1,2	61-98002	Blower, 115 V.AC, 50/60 Hz.
	-	88253	Blower Power Cord & Plug
	DS1	21-61216	POWER Indicator Light; Red; 115 V.AC
	-	21-61217	Switch Cap, "POWER"
	DS2	21-61193	ON Indicator Light, Green (with S2)
	DS3	41103	HMI Bulb, 1200 Watt
	M1	81-32007	Elapsed Time Meter, 115 V.AC 60 Hz.
	S1	39260	Interlock Switch, Pushbutton
	S2	21-61193	Lighted Pushbutton Switch, ON/OFF

EXPORT

Ref.	Desig.	Part No.	Description
	B1,2	81272	Blower, 230 V.AC, 50/60 Hz.
	-	88253	Blower Power Cord & Plug
	DS1	21-61216	POWER Indicator Light; Red; 230 V.AC
	-	21-61217	Switch Cap, "POWER"
	DS2	21-61193	ON Indicator Light, Green (with S2)
	DS3	41103	HMI Bulb, 1200 Watt
	M1	81-32003	Elapsed Time Meter, 115 V.AC 50 Hz.
	S1	39260	Interlock Switch, Pushbutton
	S2	21-61193	Lighted Pushbutton Switch, ON/OFF (with DS2)

FIGURE 1
Parts List

Item	Part No.	Description
1	25396	Screw, 10-32 Captive
2	81-28002	Hand Rail
3	41-70004	Washer, Hand Rail
4	41908	Rear Panel (Welded to Item 6)
5	41-35023	Hand Rail Fastening Nut, 1/4-28 Hex
6	41908	Lamphouse Cover, Welded Assembly (incl. Item 4)
7	41315	Bottom Cover, Welded Assembly
8	11-40037	AC Power Cord
9	41330	Captive Screw
10	41292	Lens Housing, Welded Assembly
11	41-51030	Screw, 6-32 x 3/16" Pan Head
12	41304	Long Throw Lens
13	41289	Lens Ring
14	81-28002	Hand Rail
-	41326	Lens Assembly, Long Throw (Items 10-14)
15	41294	Lens Ring
16	41305	Medium Throw Lens
17	81-28002	Hand Rail
18	41296	Lens Housing, Welded Assembly
19	41-51030	Screw, 6-32 x 3/16" Pan Head
-	41327	Lens Assembly, Medium Throw (Items 15-19)
20		Lens Ring
21		Short Throw Lens
22		Lens Housing, Welded Assembly
23	41-51030	Screw, 6-32 x 3/16" Pan Head
-		Lens Assembly, Short Throw (Items 20-23)
24	41-51281	Mounting Screw, 1/4-20 x 1/2" Button Head

FIGURE 2

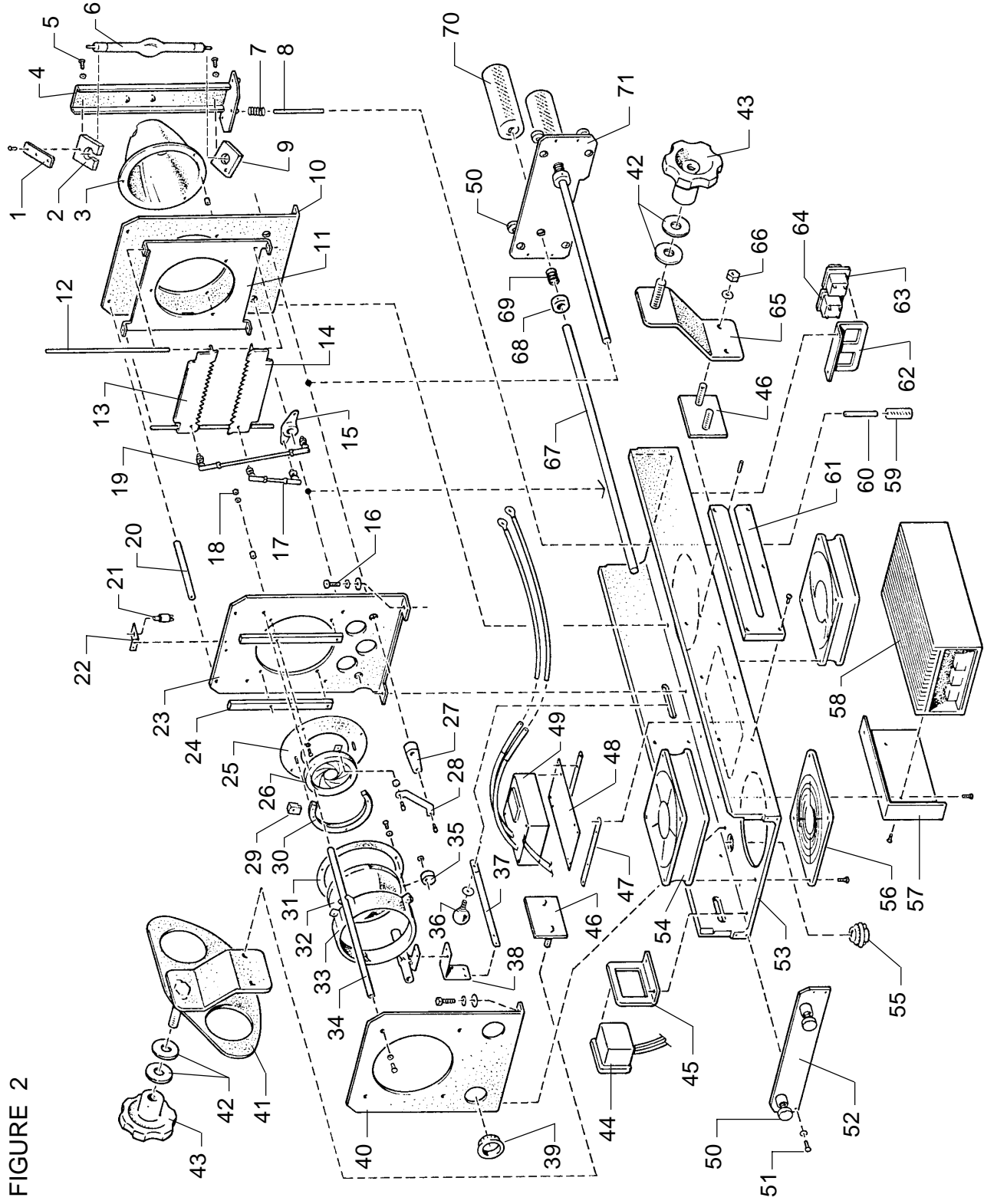

FIGURE 2
Parts List

Item	Part No.	Description
1	41257	Bulb Contact
2	41255	Upper Bulb Retainer
3	41300	Reflector
-	41-51075	Mounting Screw, 8-32 x 1" Bind Head
-	41-35008	Spacer
4	41907	Bulb Mounting Pedestal
5	41-51490	Mounting Screw, 6-32 x 3/8" Pan Head
6	41103	HMI Bulb, 1200 Watt Double-Ended
-	01304	Mounting Screw, 8-32 x 5/16" Pan Head
7	11-58013	Compression Spring (3 req'd.)
8	41337	Adjusting Shaft, Bulb Positioning (3 req'd.)
9	41254	Lower Bulb Retainer
10	41242	Reflector Mounting Plate
11	41250	Chopper Mounting Plate
12	41248	Chopper Slide Rod (2 req'd.)
13	41278	Upper Chopper Blade Assembly
14	41279	Lower Chopper Blade Assembly
15	41253	Actuator Arm, Choppers
16	41-51122	Mounting Screw, Iris Plate; 1/4-20 x 3/4" Hex Head
17	41312	Pull Rod, Short
-	41310	Ball Joint Elbow (2 req'd.)
18	41-51629	Gobo Channel Mounting Screw, 8-32 x 5/8" Phil. Head
19	41310	Ball Joint Elbow (2 req'd.)
-	41311	Pull Rod, Long
20	41276	Spacer Rod
21	31-61030	Top Cover Interlock Switch (S1)
22	65322	Switch Mounting Bracket
-	00167	Mounting Screw, 6-32 x 1/2" Flat Head
23	41242	Iris Mounting Plate
24	41301	Gobo Slide Channel (2 req'd.)
25	41263	Iris Back Plate
26	24374	Iris
27	41261	Iris Actuator Collar
28	41237	Iris Actuator Arm
29	25386	Iris Clamp (2 req'd.)

FIGURE 2 Parts List (continued)

Item	Part No.	Description
30	41264	Iris Spacer Plate
31	41265	Lens Retaining Ring
32	41302	Condensor Lens
32	41281	Condensor Lens Mounting Ring
34	41277	Lens Ring Guide Rod
35	41271	Phenolic Bushing
36	48103	Knob, Red Plastic
-	41370	Threaded Shaft
-	41-70004	Flatwasher, 1/4"
37	41229	Slide Bar
38	41275	Slide Bar Transfer Bracket
39	31-07003	Bushing
40	41252	Optical System Front Plate
41	41284	Saddle Bracket & Brake Quadrant, Welded Assembly
42	41-70008	Flatwasher, 1/2" Steel
43	45153	Clamping Knob, Cast Aluminum
44	81-32007	Elapsed Time Meter (M1), 60 Hz.
-		Elapsed Time Meter (M1), 50 Hz.. (Export)
45	41228	Meter Mounting Bracket
46	25389	Stud Plate, Balance Slide
47	41317	Igniter Retaining Strap (2 req'd.)
48	25415	Igniter Mounting Plate
49	25447	Igniter Assembly (incl. Item 48)
50	41330	Captive Screw
51	41-51540	Screw, 8-32 x 3/8" Phillips Head
52	41308	Base Rail Front Plate
53	41226	Base Rail
54	61-98002	Blower (B1,B2), 115 V.AC, 50/60 Hz.
-	81272	Blower (B1,B2), 230 V.AC, 50/60 Hz. (Export)
55	11-40037	Cable Clamp (incl. with Figure 1, Item 10 Cord)
56	83131	Blower Grille
57	25417	Mounting Bracket, Power Supply

FIGURE 2 Parts List (continued)

Item	Part No.	Description
58	25446	HMI Power Supply Assembly
59	51168	Knurled Knob, Bulb Positioning Control (3 req'd.)
60	41336	Spacer, Bulb Adjustment (3 req'd.)
61	25387	Balance Slide Bracket (2 req'd.)
62	41227	Switch Mounting Bracket
63	21-61193	Lighted Switch (S3 & DS2), ON/OFF
64	21-61216	Indicator Light (DS1), POWER
65	41283	Saddle Bracket, Welded Assembly
66	00809	Hexnut, Balance Slide Lock; 3/8-16 (4 req'd.)
67	41319	Control Rod (2 req'd.)
68	41320	Locking Collar (2 req'd.)
69	51-58017	Compression Spring (2 req'd.)
70	41318	Control Handle (2 req'd.)
71	41309	Back Plate

FIGURE 3

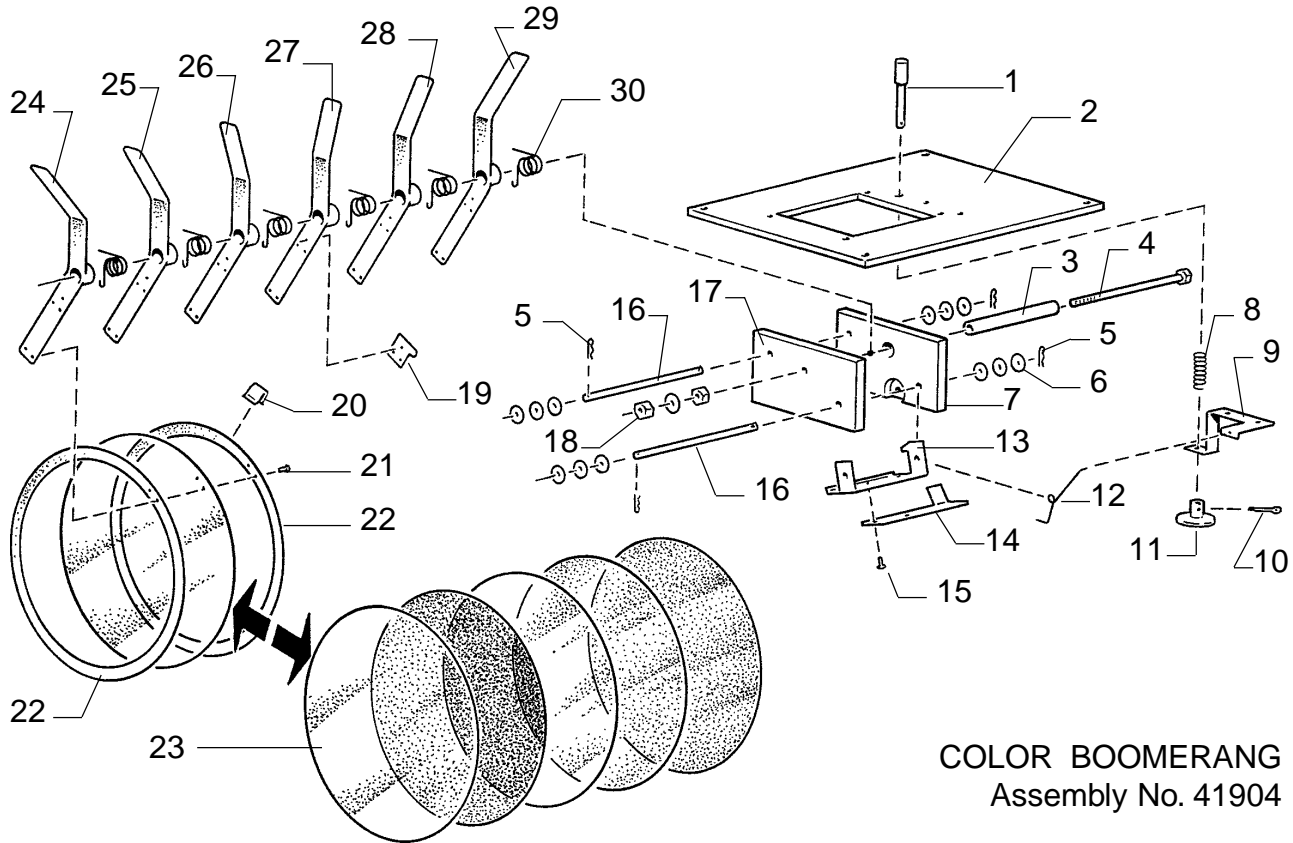

COLOR BOOMERANG
Assembly No. 41904

Item	Part No.	Description
1	45308	Color Release Pushbutton
2	41239	Boomerang Cover Plate
3	45306	Pivot Stud Bushing
4	01743	Pivot Stud Bolt, 1/4-20 x 3-1/2"
5	01704	Hitch Pin (4 req'd.)
6	41-70002	Washer (12 req'd.)
7		Retainer Plate, Rear
8	51-58029	Compression Spring
9	41240	Color Release Guide Bracket
10	00919	Cotter Pin
11	41234	Color Release Plunger
12	45310	Torsion Spring, Release Arm
13	45309	Color Arm Catch Bracket
14	41260	Trip Lever
15	41-51012	Screw, 4-40 x 1/4" Button Head
16	45304	Stop Pin, Color Arm Travel

FIGURE 3 Parts List (continued)

Item	Part No.	Description
17	18121	Retainer Plate, Front
18	01754	Nylon Hexnut, 1/4-20 (2 req'd.)
-	00889	Shakeproof Lockwasher, 1/4"
19	45308	Hook (early models only)
20	46150	Clip (3 req'd. per Color Holder)
21	01515	Screw, 4-40 x 1/4" (2 req'd. per Color Holder)
22	18118	Color Frame (2 req'd. per Color Holder)
23*	47215	Color Gel, Light Red (RoscoLux #26)
-	47216	Color Gel, Primary Blue (RoscoLux #80)
-	47217	Color Gel, Sky Blue (RoscoLux #68)
-	47218	Color Gel, Daylight Blue (RoscoLux #65)
-	47219	Color Gel, Flesh Pink (RoscoLux #34)
-	47220	Color Gel, Golden Amber (RoscoLux #21)
24	25412	Color Selector Arm
25	25408	Color Selector Arm
26	25407	Color Selector Arm
27	25411	Color Selector Arm
28	25410	Color Selector Arm
29	25409	Color Selector Arm
30	45303	Torsion Spring (6 req'd.)
		NOT SHOWN
	25396	Boomerang Mounting Screw, Captive (4 req'd.)

* Install *less dense* colors (pink, amber) **closest** to light source

FIGURE 4

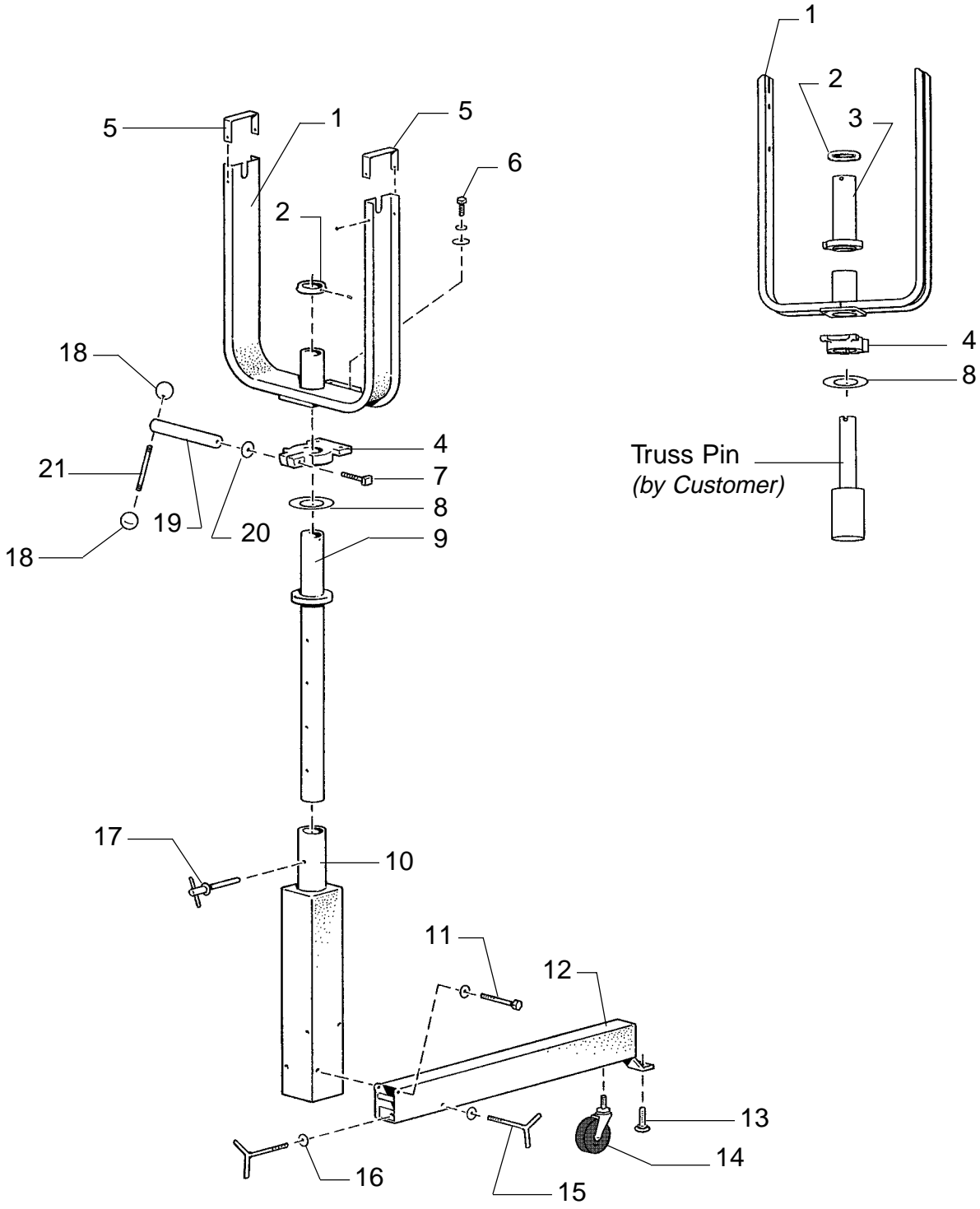

PARTS LIST

Figure 4

Item	Part No.	Description
1	41243	Yoke, Welded Assembly
2	65431	Inner Tube Retaining Collar
3	41325	Yoke Pivot, Welded Assembly
4	83381	Swivel Clamp Collar
5	25420	Strap (2 req'd.)
6	00695	Screw, 1/4-20 x 1" Hex Head
-	00876	Lockwasher, 1/4" Split Ring
-	00852	Flatwasher, 1/4"
7	00684	Screw, 3/8-16 x 2-1/4" Square Head
8	65420	Thrust Bearing
9	65824	Inner Tube, Welded Assembly
10	83742	Outer Tube & Base Column, Welded Assembly
11	41-51399	Screw, 7/16-14 x 3" Hex Head (4 req'd.)
-	41-70008	Flatwasher, 1/2"
-	41-35056	FlexLock Hexnut, 7/16-14
12	83744	Base Leg, Welded Assembly (4 req'd.)
13	49226	Leveling Foot (4 req'd.)
14	49208	Caster (4 req'd.)
15	83745	Leg T-Bolt (4 req'd.)
16	41-70007	Flatwasher, 7/16"
17	48395	Height Adjusting Pin, 3/8" Diameter
18	10048A	Knob, Red Plastic
19	47290	Swivel Clamping Shaft
20	41-70007	Thrust Washer
21	49130	Handle Shaft

