



FOLLOW SPOTLIGHT INSTRUCTION MANUAL

Equipment Type 7201156 • Rev. November 2007



a division of Ballantyne of Omaha, Inc.

4350 McKinley Street • Omaha, Nebraska 68112 USA
Tel (402) 453-4444 • Fax (402) 453-7238 • www.strong-lighting.com

PREFACE

THE STRONG XENON SUPER TROUPER® is a direct current follow spotlight system complete with a xenon lamphouse, power supply, optical system, and a floor stand and yoke assembly. An optional six-color, self cancelling boomerang (Order No. 7201188; see Figure 7) may be ordered with new equipment, or it can be added at a later date.

ONLY THE SPECIAL XENON POWER SUPPLIES manufactured by Strong International can be used with the xenon spotlight. For installation and operation of the power supply, see the instruction manual furnished separately.

THE XENON LAMPHOUSE utilizes a deep ellipse dichroic metal reflector designed to operate in a fixed position with a horizontally mounted xenon bulb as the light source. A heat filter is located in the front of the lamphouse to reduce the heat at the optical system and color boomerang.

ONLY XENON BULBS designed for horizontal operation should be used in this spotlight. The lamphouse is designed for use with the standard 2000 watt horizontal theatre bulb, and an optional Adapter Kit (Order No. 7201192) allows use of 1000 and 1600 watt bulbs. See the listing in this manual for the approved types and necessary adapters.

ADJUSTMENT CONTROL for positioning the xenon bulb is located at the rear of the lamphouse. The adjustments are for the horizontal, vertical, and focus control of the bulb.

THE LAMPHOUSE INSTRUMENT PANEL is equipped with an ammeter and running time meter. The ammeter indicates the operating current of the lamp, and the running time meter records the number of hours the lamp has operated. The xenon bulb is ignited and extinguished by use of the LAMP switch mounted on the instrument panel.

THE LAMP BLOWER, internally wired in the lamp, operates on 115 V.AC and is required to keep the seals on the bulb at a safe operating temperature. This blower will operate continuously until power is turned off at the main line switch to the xenon power supply. An air flow switch in the lamphouse prevents operation of the xenon lamp if the blower is not operating, or if airflow is inadequate. If additional cooling is required (i.e. 50 Hertz power source), an optional Exhaust Blower Assembly (7201036; see Figure 8) may be mounted to the top of the lamphouse.

THE LAMPHOUSE is supplied with a 11 foot (3.35 m) cable containing the two DC leads, the ground lead, and all AC control leads. The cable terminates in a multiple-pin MS connector to mate to a corresponding receptacle on the xenon power supply.

WHEN TRANSPORTING the follow spotlight, it is recommended that the xenon bulb be removed from the lamphouse and placed in its original shipping carton with the protective cover on the bulb to prevent breakage.

LAMPHOUSE - POWER SUPPLY Interconnection Diagram

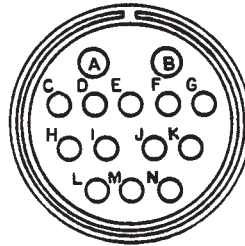
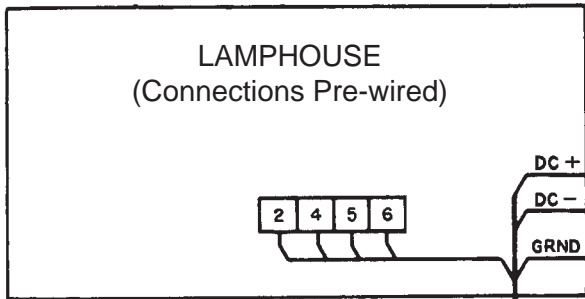

Pin	Wire No.
A	DC-
B	DC+
C	2
E	4
F	5
G	6
M	Grnd

Lamphouse
Cable Assembly

SYSTEM MUST BE GROUNDED
All wiring must conform to local codes;
shield lamphouse cable in conduit if
required.

Check Slide Switch (below) on Power
Supply for correct positioning.

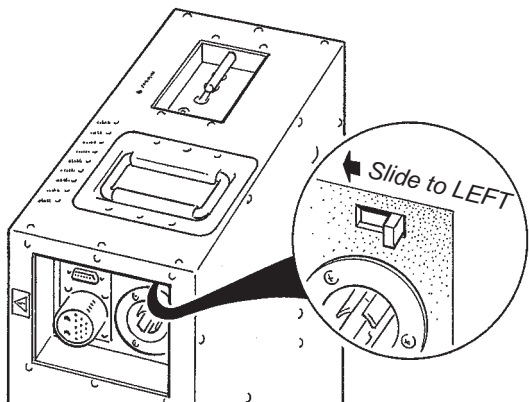
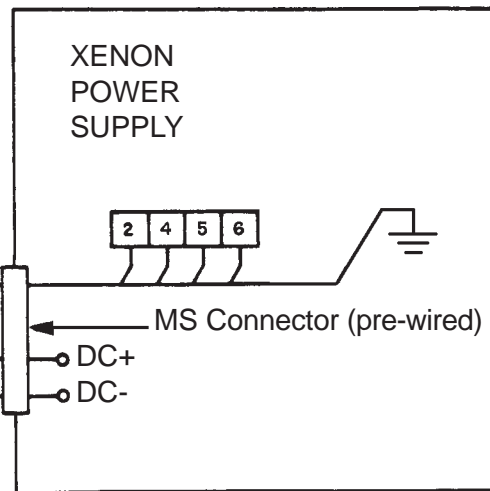

INSTALLATION AND SETTING UP SPOTLIGHT

THE XENON SUPER TROUPER is shipped in sections which must be assembled. The Folding Base Stand Assembly 65826000 (see Figure 6) is shipped collapsed, and requires only folding down and pinning the four base legs.

WHEN INSTALLED in a permanent location, the leveling feet must be removed, and the clearance holes in the base leg brackets used for hardware (user supplied) to bolt the base to the floor or platform. If it is desired to have the unit portable, when operating, the leveling feet must be adjusted down until the weight of the spotlight has been shifted from the casters to the leveling feet.

THE INNER TUBE and support yoke has three holes to permit adjusting the height of the spotlight. The three holes are on four-inch centers and will allow an optical height of approximately 53 inches, 57 inches, and 61 inches above floor level to the optical center of the lamphouse and lens system. The leveling feet may be adjusted through an additional two inch range. Insert the height location pin (Figure 5, Item 16) through the hole in the outer tube and one of the holes in the inner tube.

THE HORIZONTAL SWING and vertical tilt locking knobs are on the right hand (operating) side of the yoke assembly. Tighten both of these locking devices (Figure 6, Items 19 & 21) securely before attempting to place the lamphouse and lens system on the support yoke.

PLACE THE LAMPHOUSE and lens system on the yoke assembly (Figure 6, Item 4), with the spot size control handle to the right hand (operating) side, the same as the locking controls on the yoke. Line up the four mounting holes in the bottom of the base rail with four slotted holes in the support yoke and secure with the four 5/16-18 wing screws. There are (2) sets of four mounting holes to insure correct balance of the spotlight with or without the optional color boomerang. An optional Counterweight Kit (7201191) is also available for setting concise balance adjustments.

THE OPTIONAL COLOR BOOMERANG (7201188) mounts to the front opening of the optical system on three studs protruding from the front of the optical system housing. Secure the boomerang using the (3) screws provided, and install the safety cable between the boomerang housing and the spotlight frame.

ATTACH THE LAMPHOUSE CABLE connector to the receptacle on the xenon power supply. Align the pins before tightening the locking ring. Do not energize the power supply before first completing the bulb installation procedure.

CHECK THE SLIDE SWITCH on the xenon power supply cabinet and verify that it has been paced in the "LAMPHOUSE/SPOT" position. See the illustration on the inside front cover of the Xenon Power Supply instruction manual.

SAFETY PROCEDURES

THE XENON BULB is highly pressurized. When ignited, the normal operating temperature of the bulb increases the pressure to a level at which the bulb may explode if not handled in strict accordance to the manufacturer's operating instructions. The bulb is stable at room temperature, but may still explode if dropped or otherwise mishandled.

REFER bulb replacement and service to QUALIFIED PERSONNEL with adequate protective clothing (face shield, clean cotton gloves, welder's jacket). For routine lamphouse service, observe the following rules:

1. Allow the bulb to cool to room temperature before opening the lamphouse. Put on protective clothing described above.
2. De-energize the xenon power supply at the AC source before opening the lamphouse compartment.
3. When possible, encase the bulb in its protective cover when cleaning or servicing the lamphouse interior. The bulb, when outside the lamphouse, must be encased in the cover.
4. Clean the bulb after it has cooled to room temperature. Do not touch the quartz envelope of the bulb; fingerprints will burn in and create hot spots which may shorten bulb life. If fingermarks are made, they should be carefully removed with methyl alcohol and cotton prior to bulb operation.
5. Never view an ignited bulb directly. **BLINDNESS OR PERMANENT EYE DAMAGE MAY BE INCURRED.**
6. Use only xenon bulbs designated as OZONE FREE. When possible, vent the lamphouse exhaust to outside atmosphere.
7. Maintain the lamphouse blower in good operating condition. Keep the blower inlet clean for unrestricted air flow.
8. To insure maximum bulb life, operate the lamphouse blower and the exhaust system for *at least* ten minutes after extinguishing the bulb.
9. If returning a bulb for warranty adjustment, pack it in its original shipping container. Complete and return all required warranty information.
10. Dispose of expired bulbs that are beyond warranty in the following manner: Wrap the bulb tightly in several layers of canvas or heavy cloth. Place it on a hard surface and shatter the envelope with a sharp hammer blow. **DO NOT** place an unshattered bulb in an ordinary refuse container.
11. **DO NOT PERMIT UNAUTHORIZED PERSONNEL TO PERFORM OR ATTEMPT ANY PHASE OF XENON BULB HANDLING OR SERVICE.**

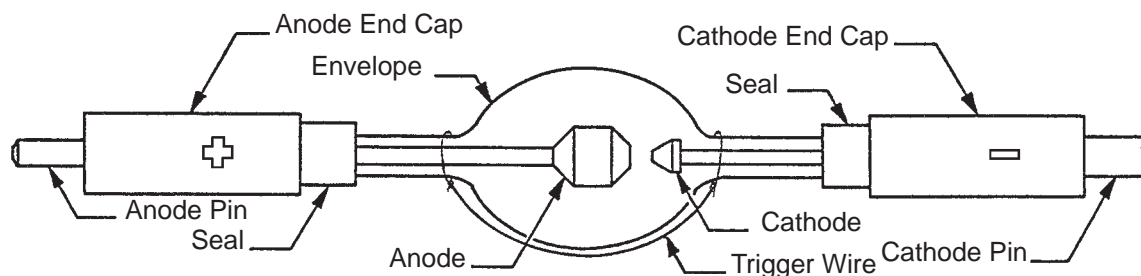

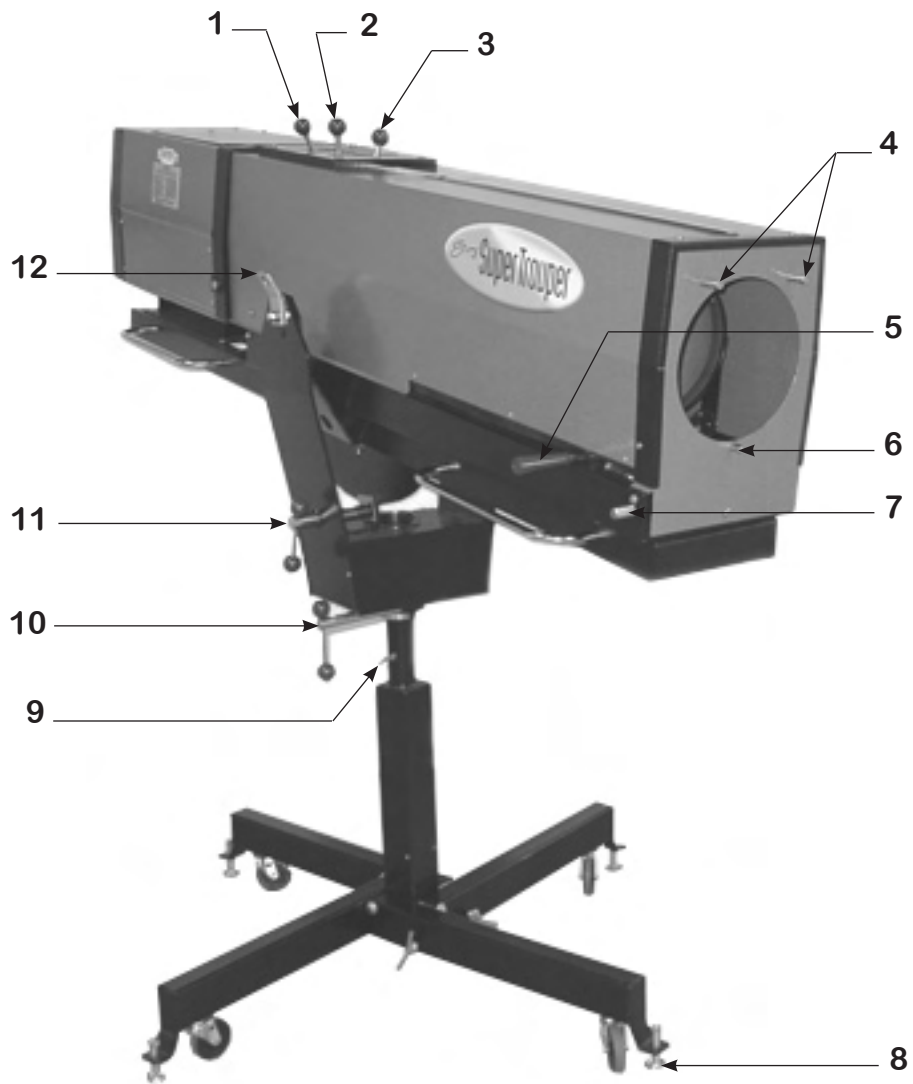

- | | |
|--|------------------------------------|
| 1. Fade-Out Mechanism Control Lever | 7. Spot Focus Control Knob |
| 2. Masking Shutter (Chopper) Control Lever | 8. Leveling Foot |
| 3. Iris Control Lever | 9. Height Adjust Pin |
| 4. Boomerang Mounting Stud, Upper* | 10. Horizontal Swing Control Lever |
| 5. Spot Size Control Handle | 11. Vertical Tilt Control Lever |
| 6. Boomerang Mounting Stud, Lower* | 12. Lifting Strap |

* Color Boomerang *optional*; see Figure 7

EXHAUST SYSTEM INSTALLATION

IF THE SPOTLIGHT is installed in a closed booth, it is recommended to vent the lamphouse exhaust to outside atmosphere to remove the heat from the booth. An optional lamphouse top cover plate with an exhaust stack (Part No. 7201222) may be ordered from Strong and installed in place of the standard top cover plate (see Parts List, Figure 2, Item 27).

THE EXHAUST STACK of the optional lamphouse cover plate is designed to fit a six-inch diameter duct. The exhaust system must be designed and installed in a manner as to eliminate any possibility of a down draft or of rain dripping into the lamphouse. The exhaust fan must be capable of removing 750 lineal feet per minute (150 cfm) of air from each lamphouse.

TO PERMIT MOVEMENT of the follow spotlight, install a section of six-inch diameter, non-flammable, flexible ducting between the lamphouse exhaust stack and the projection booth exhaust system. Two screw holes in the exhaust stack can be used to secure the ducting with #6 self-tapping sheet metal screws.

IF ADDITIONAL BULB COOLING is required (i.e. 50 Hertz power source), an optional Exhaust Blower Assembly (Part No. 7201036; see Figure 8) may be mounted to the existing top cover of the lamphouse. This blower assembly exhausts into the surrounding air and does not allow connection to a ducted exhaust system.

THE RADIATION from some xenon bulbs can convert the oxygen in the surrounding air to ozone. In large quantities, ozone can endanger health, but it spontaneously changes back into oxygen in a very short time, especially if it mixes with a large volume of air (as in an auditorium, arena, or outdoors). Most currently manufactured xenon theater bulbs are classified as *ozone free* and do not release ozone.

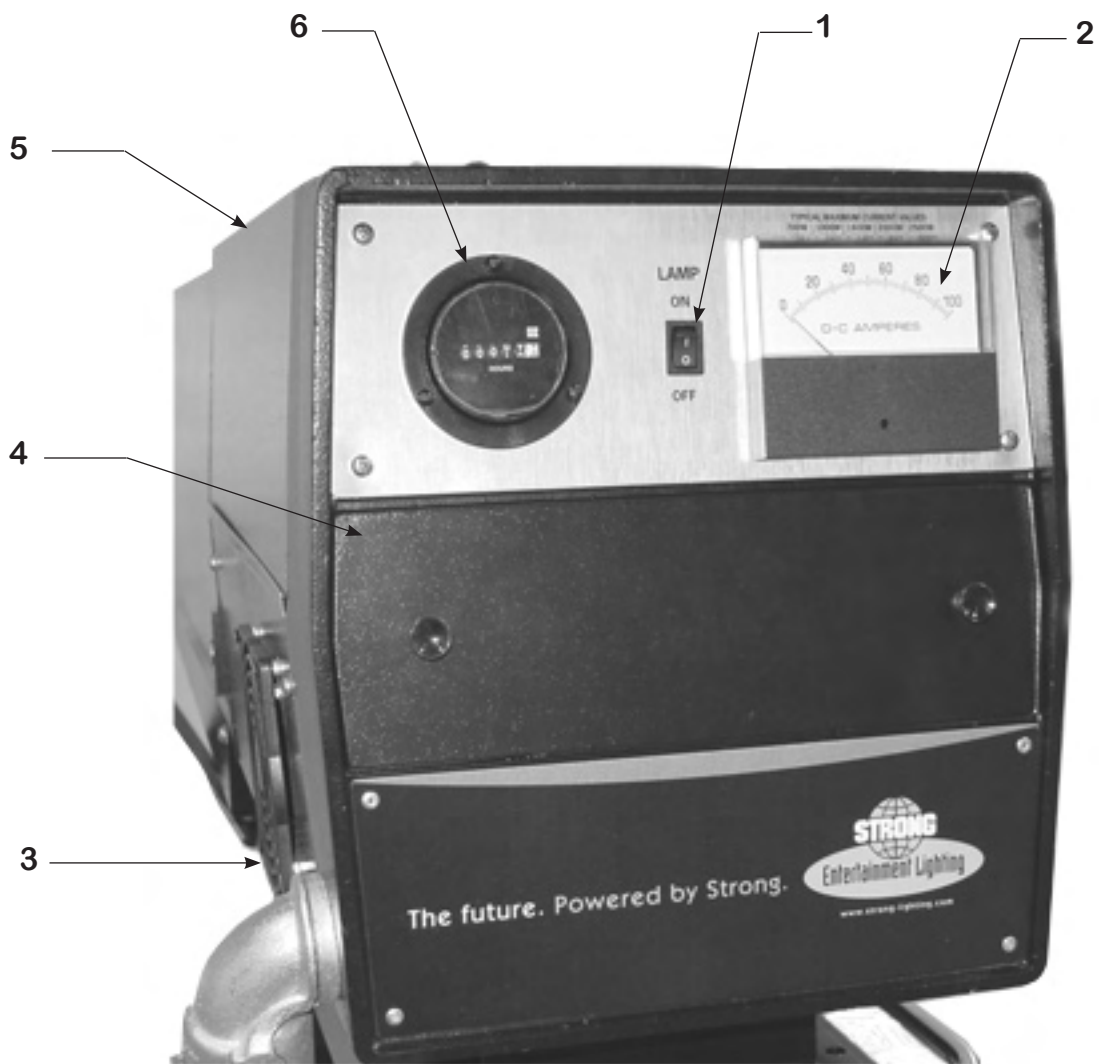

1. LAMP Switch (ON-OFF)
2. Ammeter
3. Air Intake, Blower
4. Cover, Bulb Adjust Controls
5. Top Cover, Lamphouse
6. Elapsed Hour Meter

1000, 1600 WATT BULB INSTALLATION
Requires optional/Bulb Adapter Kit 7201192

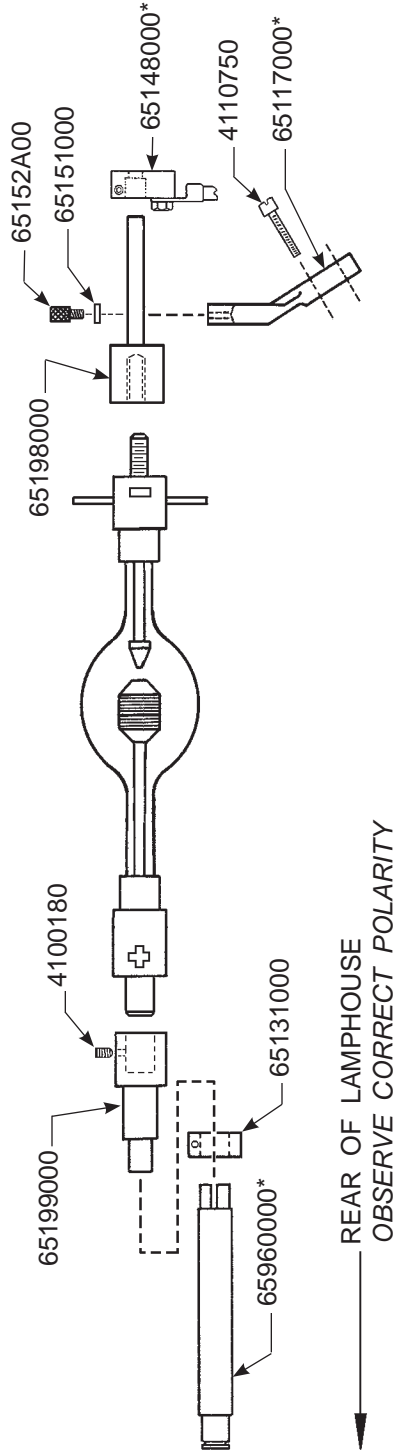

* Replace Collet, Front Bulb Support, and Cathode Clamp before installing bulb.

Part No.	Description
65117000	Bulb Support Yoke
65131000	Anode (+) Contact Clamp
65148000	Cathode (-) Contact Clamp
65151000	Retainer Plate
65152A00	Thumbscrew (2 req'd.)
65198000	Cathode Adapter
65199000	Anode Adapter
65960000	Rear Bulb Support Collet
4080870	Clamping Screw (for 65131000 & 65148000)
4100180	Set Screw, Anode Adapter
4110750	Bulb Support Mounting Screw
4250373	Lead Mounting Screw (for 65131000 & 65148000)
<i>NOT SHOWN</i>	
65948000	Negative (-) Lead Assembly, 29" (Clamp to Shunt)
65966000	Positive (+) Lead Assembly (incl. 65131000)

1000 Watt Operation: 50 Amperes Nominal
DO NOT EXCEED 58 AMPERES

1600 Watt Operation: 65 Amperes Nominal
DO NOT EXCEED 70 AMPERES

BULB INSTALLATION

CAUTION: OBSERVE ALL SAFETY PROCEDURES. Put on the protective face mask. Wear clean cotton gloves to prevent marking the quartz envelope of the bulb with fingerprints.

REMOVE THE TOP COVER of the lamphouse by removing the four Holt head (tamperproof) screws with the special screwdriver provided.

NO BULB ADAPTERS are required to install the 2000 watt bulb in the Xenon Super Trouper lamphouse. Components and adapters required to install the 1000 watt or 1600 watt bulb in the lamphouse are available in an optional Adapter Kit (Part No. 7201192). See the Bulb Adapter illustration on the facing page for the correct adapters and method of assembly.

1000 & 1600 Watt Bulb Installation

DISMOUNT AND REMOVE the front bulb mounting ring assembly from the air duct casting in front of the reflector and replace it with the smaller bulb support yoke casting included in the 7201192 Bulb Adapter Kit. Install the 65148000 cathode clamp in place of the standard 2 kW clamp. Remove the rear bulb support collet assembly (nylon rod and brass socket) from the bulb focus assembly behind the reflector and replace it with the collet assembly included in the Bulb Adapter Kit.

ASSEMBLE THE REQUIRED ADAPTERS to the 1000 or 1600 watt bulb prior to inserting the bulb into the lamphouse. Be very careful **not** to apply any strain on the quartz envelope when installing adapters. Handle the bulb by its metal end caps only. Screw the threaded cathode adapter onto the negative stud so it seats firmly against the shoulder of the cathode (-) end cap. Apply torque using the pins on the cathode end cap. Slip the anode adapter with set screw over the positive stud, up to the shoulder of the anode (+) end cap. Tighten all fasteners securely to insure a good electrical connection.

REMOVE THE PLASTIC PROTECTIVE COVER from the xenon bulb only if necessary. Insert the bulb through the top of the lamphouse, between the reflector support and the front casting. Pass the anode (+) end of the bulb through the hole in the reflector, taking care **not** to touch the surface of the reflector.

INSERT THE ANODE ADAPTER STEM of 1000 and 1600 watt bulbs into the rear support collet. The stem must be inserted into the socket as far as possible to permit full focus travel of the bulb. Place the stem of the cathode adapter into front bulb support yoke, pivot the retaining plate to its closed position, and tighten the (2) thumb screws. Tighten the socket head clamping screw in the anode contact securely to insure a good electrical contact.

INSTALL THE CATHODE LEAD CONTACT over the end of the cathode adapter up to the shoulder of the contact and tighten the clamping screw securely. Dress the lead in front of the air duct to minimize the shadow.

BULB INSTALLATION (continued)

2000 Watt Bulb Installation

THE 2000 WATT bulb mounting components include a shock mount support at the front of the lamphouse. Insert the 2000 watt bulb through the top of the lamphouse, passing the anode (+) end through the hole in the reflector. Pass the anode pin as far as possible to the rear of the lamphouse to permit sliding the cathode (-) end cap through the ring of the shock mount. Temporarily removing the 65131000 anode clamp from the brass socket of the collet allows added clearance for the bulb. Gently rotating or turning the bulb while sliding the cathode end cap through the shock mount will slightly compress the coil spring and prevent stripping the spring from its channel in the ring.

REPLACE THE ANODE CLAMP over the rear bulb socket. Insert the anode (+) pin of the bulb into the rear support collet, and firmly tighten the socket head clamping screw. Slide the 65410000 cathode contact clamp over the cathode (-) pin and tighten securely.

AN ALTERNATE METHOD of installing the 2000 watt bulb is to dismount the 83748000 shock mount ring from the front bulb support assembly by removing the 4100620 socket head clamping screw. Slide the ring over the cathode (-) end cap of the bulb, and install the bulb by inserting the anode (+) end cap through the reflector center hole and seating the anode pin into the rear support collet. Remount the ring to the 83364000 base bracket of the front bulb support using the socket head screw. DO NOT dismount or reposition the factory-aligned base bracket. Secure the anode (+) clamping screw; install and tighten the cathode (-) contact clamp.

THE SOCKET HEAD SCREW which mounts the 83748000 bulb support ring to the 83364000 base bracket must be tightened securely enough to *clamp* the upright bulb support ring in a vertical (90°) position and prevent its tilting forward or back as the bulb is focused. The end cap of the bulb should touch only the coils of the 83410000 shock mount spring to allow the bulb to slide forward and back with a minimum of friction and *no stress* on the quartz envelope.

OBSERVE THE POSITION of the Trigger Wire on the xenon bulb relative to the point where the bulb passes through the center hole of the reflector. Some bulb manufacturers attach one end of the trigger wire to the anode end cap; if this trigger wire approaches the reflector too closely, the DC current may follow this path to ground and prevent bulb ignition. In this event, detach the trigger wire from the anode end cap and loop it around the bulbous portion of the envelope as illustrated on the line drawing at the bottom of the SAFETY PROCEDURES page.

IT IS RECOMMENDED to establish a routine for periodically checking all electrical connections for tightness, particularly those at the bulb. A loose connection in the DC circuit will cause failure of the contacts and leads, and may destroy the bulb.

THE REFLECTOR is optically positioned at the factory. Do not alter the position of the reflector by adjusting the threaded tie rod located in the upper corner of the lamphouse.

2000 WATT BULB INSTALLATION

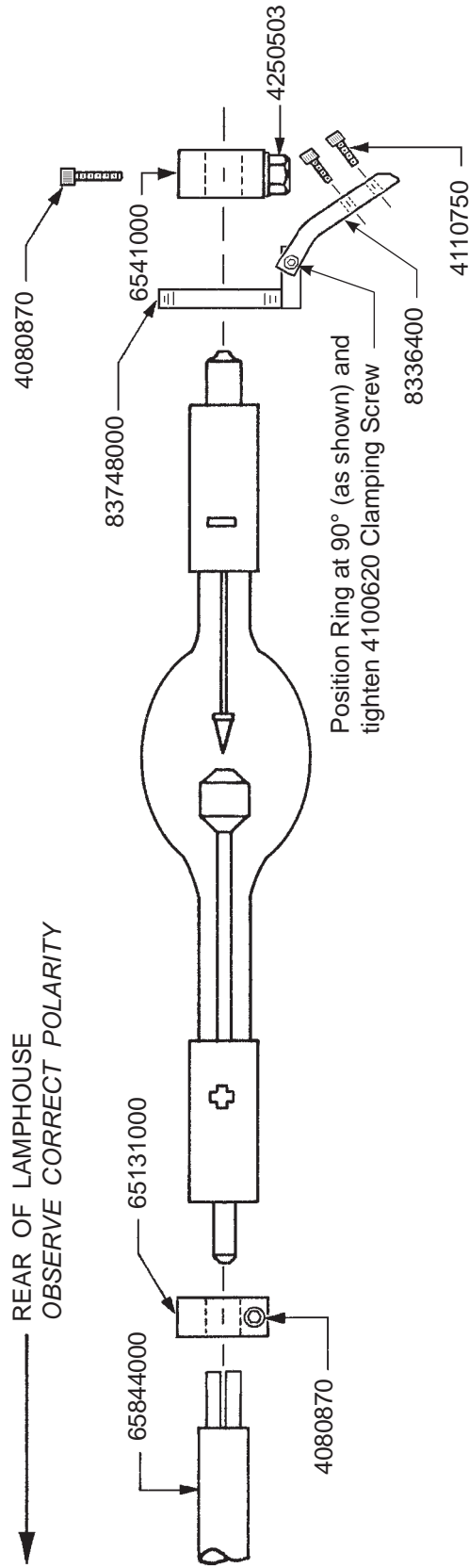

Part No.	Description
65131000	Anode (+) Contact Clamp
65410000	Cathode (-) Contact Clamp
65844000	Rear Bulb Support Collet, 2 kW
83364000	Front Bulb Support Base Bracket
83410000	Coil Spring (<i>inside 83748000; not shown</i>)
83748000	Front Bulb Support Ring
4080870	Contact Clamping Screw
4100620	Support Ring Clamping Screw
4110750	Bulb Support Bracket Mounting Screw
4250503	Lead Mounting Screw

NOT SHOWN

- 65948000 Negative (-) Lead Assembly, 29" (Clamp to Shunt)
- 65966000 Positive (+) Lead Assembly (incl. 65131000)

DETACH & DISCARD ANY FACTORY-MOUNTED LEAD CONNECTED TO BULB END CAP

SHORT 2000 WATT (Type "HS") BULB NOT USED IN XENON SUPER TROUPEUR

2000 Watt Operation: 75 Amperes Nominal
DO NOT EXCEED 90 AMPERES

OPERATION

REMOVE THE PLASTIC COVER from the xenon bulb. **Do not** ignite the lamp with the protective shipping cover on the bulb.

A GLASS HEAT FILTER is supplied to reduce the temperature at the optical system and color gels. This filter is a narrow glass strip that covers only the center portion of the beam. Insert the heat filter in the bracket provided on the inside of the lamphouse at the front opening (see Figure 2, Item 2). Place the filter in position *with the coated surface facing the bulb*. The coated surface is indicated by a small XX or other marking. To prevent damage to optical system components, **do not** operate the spotlight with the filter removed or reversed.

SECURE THE LAMPHOUSE COVER with the (4) tamperproof screws using the special screwdriver provided. The cover must be securely in position to actuate the interlock switch and permit lamp ignition.

CLOSE THE CIRCUIT BREAKER on the xenon power supply to energize the power supply. The blowers in the power supply and in the lamphouse will start; the lamphouse blower will actuate the air intake interlock switch to permit bulb ignition. The lamp and power supply blowers will operate continuously until the xenon power supply is de-energized.

PLACE THE LAMP SWITCH in the ON position and the xenon bulb will ignite. Allow a few minutes for the current to stabilize, and read the lamphouse ammeter. The bulb must be operated within the current range specified by the bulb manufacturer. The ranges for the xenon bulbs approved for use with the Xenon Super Trouper are as follow:

<u>WATTAGE</u>	<u>NOMINAL CURRENT</u>	<u>DO NOT EXCEED</u>
1000	50 A.	58 A.
1600	65 A.	70 A.
2000	75 A.	90 A.

ADJUST THE POWER SUPPLY as instructed in the power supply manual for the correct operating current. The current setting must be increased in time to compensate for bulb aging, but *do not*, at any time, exceed the maximum current rating.

REMOVE THE REAR COVER PANEL (two black plastic pull-type knobs) to expose the bulb position adjustment control.

THE CENTER SECTION of the control is a threaded member that focuses the bulb in relation to the reflector. Turning this adjustment moves the bulb on the horizontal plane, into or out of the reflector. Rotating this section clockwise moves the bulb away from the reflector. The small knurled screw to the left of this section can be tightened to lock the focusing mechanism in place after the bulb alignment procedure has been completed.

THE THUMB SCREWS to the left and right of the focusing control lock the horizontal and vertical position of the bulb.

BULB ADJUSTMENT CONTROLS

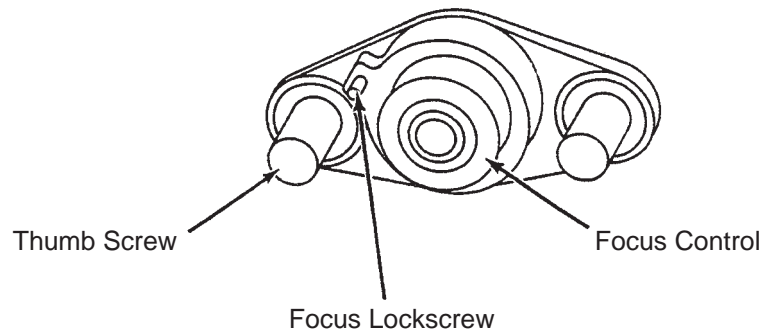

TWO METHODS, details following, are recommended to align the bulb in order to project the best light to the stage.

MOVE THE SPOT SIZE CONTROL HANDLE on the large lens carriage to the forwardmost position to project the smallest spot possible. Set the iris, choppers, and dimming control to their full *open* positions. Project the spot to a wall or similar flat perpendicular surface opposite the spotlight position.

TURN THE CENTER FOCUS CONTROL counterclockwise until a small black spot is projected on the wall. It may be well to run this adjustment both directions to permit positive identification of the dark spot.

LOOSEN THE TWO THUMB SCREWS to the left and right of the focus control just enough to permit manual movement of complete control assembly. Move the control assembly around the two thumb screws and observe the smooth dark shadow of the bulb electrode inside the shaded circle of the reflector center opening. The shadow of the electrode must be centered in the projected opening of the reflector.

MOVE THE CONTROL ASSEMBLY around the thumb screws until the dark electrode shadow is as round as possible to project. It may be necessary to again rotate the focus control to define the electrode shadow.

AFTER THE ELECTRODE SHADOW is as even around the outside as possible, tighten the two thumb screws to lock this adjustment in place, and rotate the focus control to obtain the brightest light with the best light distribution. Turn the spot focus control knob, located on the front of the lens mechanism, to sharpen the edge of the spot.

THE SECOND METHOD of aligning the xenon bulb is to project the spot to the stage, and using the bulb adjustment controls, obtain a “hot spot” in the projected spot. Center this “hot spot” in the projected spot by moving the entire control section around the two thumb screws. Once

the “hot spot” is centered in the projected spot, lock the adjustment control in position with the two thumb screws and rotate the focus control to obtain a spot with an even distribution of light. Turn the spot focus control knob at the front of the lens mechanism to sharpen the edge of the spot.

THIS ADJUSTMENT should not be disturbed until the xenon bulb is replaced. At this time it will be necessary to repeat the alignment procedure.

REPLACE THE REAR COVER PANEL over the bulb adjustment control mechanism. Secure using the plastic fasteners.

BECAUSE OF MANUFACTURING TOLERANCES and normal bulb aging, it may be necessary to operate one lamp at slightly higher or lower current than others to balance light output between multiple units. These adjustments are made at the xenon power supply.

TO EXTINGUISH THE ARC, place the LAMP switch in the OFF position. The blower in the lamphouse will continue running until the xenon power supply is de-energized. Allow the blower to operate and cool the bulb for *at least* five minutes after extinguishing. This measure will prolong bulb life.

HANDLING THE SPOTLIGHT

GENERALLY THE BEST POSITION for the operator to stand is near the center of the spotlight, on the right hand side, although the angle of tilt and the size of the porthole may alter the position for the most convenient operation.

EACH OPERATOR will, after a few minutes of operation, generally develop his own system and position for operating the unit.

THE HORIZONTAL SWING LOCK LEVER and vertical tilt lock lever located on the base assembly can be set to give the desired amount of friction on the spotlight swing to suit the individual operator. An optional counterweight assembly (Part No. 7201191; see Figure 7) allows adding or removing weights for concise adjustment of the spotlight balance.

THE LENS CARRIAGE FRICTION BRAKE is a nylon drag screw located on the outrider of the large lens carriage (see Figure 4, Items 16 & 17), and is preset at the factory for most satisfactory operation. Individual requirements may vary, and the brake can be adjusted to best suit the operator or to allow for a severe “down” angle. Remove the color boomerang and lens mechanism housing, loosen the nylon lock nut and tighten or loosen the screw on the friction brake to apply the desired tension. Tighten the lock nut and replace the housing and boomerang.

OPERATION OF COLOR BOOMERANG

THE OPTIONAL COLOR BOOMERANG is equipped with six color filter holders. Additional filter holders (51928000 & 51376000) can be supplied by your Strong dealer.

TO OPERATE INDIVIDUAL COLOR FILTERS, lower the desired filter selector lever. A rocker catch located in the color disc housing holds the filter in position.

TO RELEASE A COLOR, push either filter release arm upward or engage another color, thus releasing the previous color automatically.

NOTE: WHEN PLACING COLOR FILTERS in the boomerang, the *less* dense colors (amber, pink) should be placed in the holders toward the **rear** of the boomerang (closer to the arc), and those of *greater* density (red, green) should be placed in the holders toward the **front** of the boomerang (away from the arc). Use RoscoLux® (or equivalent) *high temperature* filters.

COLOR TEMPERATURE REDUCTION FILTERS, required for use with television and videotape, are available from theatrical supply dealers.

PROVISION IS MADE for “stowing” color holders for transport. When stowed, the color holders are protected from breakage or other damage caused by moving the spotlight. To enable operation of the color boomerang, detach the lower thumbscrew securing the hinged portion of the boomerang housing and fold the panels upward. This allows the color holders to drop into a “deployed” position for normal operation. An upper thumbscrew allows locking the hinged panels in the upper position. To again stow the color holders for transport, raise all six color holders to their engaged position, loosen the upper lockscrew, unfold the hinged boomerang housing, and secure in the lower position.

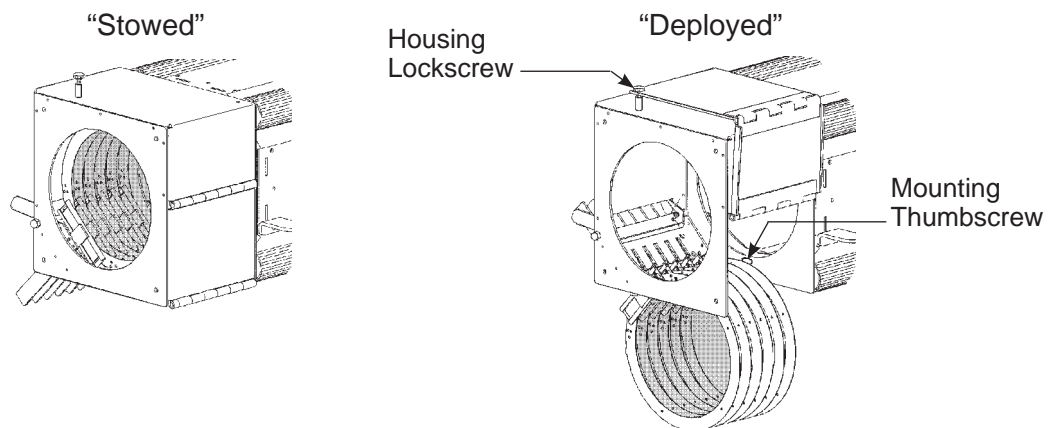

OPERATION OF OPTICAL SYSTEM

THE IRIS CONTROL is the front lever which projects through the top of the optical system housing. When this lever is to the right (as viewed from the rear of the unit), the largest aperture is provided. Smaller apertures are selected as the lever is moved to the left.

THE SPOT SIZE CONTROL HANDLE is located on the right hand side of the optical system just above the base rail. A variation of spot sizes from full flood to small spot can be obtained by moving the spot size control handle from one extreme to the other. Beam intensity is increased by this optical system when reducing from flood to spot, and maximum intensity is reached when the spot size control handle is in the extreme forward position.

THE MAXIMUM FLOOD SPOT is obtained with all three beam shape control levers to the right (toward operating side) for the largest aperture, and with the spot size control handle moved as far to the rear as possible.

SMALLER SIZED SPOTS are projected as the spot size control handle is moved forward. Most of the spot sizes needed will be produced with the iris in its maximum open position.

FOR A "HEAD SPOT," or any spot smaller than can be obtained with the spot size control handle in its extreme forward position, shift the iris control lever to the left (away from operating side) for a smaller aperture. The iris control lever should always be returned to its extreme right position before the spot size control handle is again moved to obtain larger spots.

A "DIFFUSED" SPOT is projected by sliding the spot size control handle backward toward its "flood" setting while closing the iris (aperture selector lever toward left). A "diffused" spot is a soft-edged spot with low light intensity and is seldom required.

THE MASKING SHUTTER (chopper) lever is the middle lever projecting through the top of the optical system housing. The masking shutter blades are operated by this lever to shape the projected spot to a rectangle, strip spot, or dousing.

THE DISENGAGED POSITION of the masking shutter lever is to the extreme right (toward operating side) and varying degrees of masking to complete cutoff are obtained by moving the lever to the left (away from operating side).

THE ANGLE of the masking shutter blades can be adjusted to compensate for the horizontal projection angle. Remove the color boomerang and optical system housing, and loosen the screws holding each of the masking shutter blades enough to allow movement. Ignite the bulb and adjust the angle of the *bottom* blade by tapping with a screwdriver so its projected edge lies parallel to the footlights. Tighten the screw. Operate the masking shutter lever to close the blades. Adjust the upper blade to close in line with the bottom blade and tighten the screw.

OPERATION OF OPTICAL SYSTEM (continued)

THE FADEOUT MECHANISM AND DOUSER CONTROL is the rear lever projecting through the top of the optical system cover. This lever controls the intensity of light from complete fadeout when the lever is to the left, to full intensity when the lever is to the right.

THE SPOT FOCUSING CONTROL KNOB is located on the operating side of the optical system at the forward end above the base rail. This control is used to position the lenses of the optical system for the length of throw. When making an adjustment, rotate the spot focusing control knob until the sharpest edge is obtained on the projected spot.

IF UNABLE TO ACHIEVE A "HARD" EDGE on the spot, the ribbon joining the lenses (see Figure 4, Item 12) can be lengthened or shortened by repositioning the cotter pin attaching the ribbon to the small lens carriage; see Figure 4, Item 25. The ribbon may also require resetting if the spotlight is moved from its original location to a new position with a different throw distance.

A SLOT in the lens mechanism housing, between the beam shaping control levers and the front lens, allows insertion of special media such as frost gels. Additional gel frames (Part No. 83374000) may be ordered from Strong dealers.

MAINTENANCE

THE XENON SUPER TROUPER SPOTLIGHT requires very little maintenance to keep it in good working order.

THE REFLECTOR should be cleaned periodically with a clean, soft, lint free cloth to remove any dust from the reflective surface. *Do not* use abrasive cleaners.

CHECK ALL ELECTRICAL CONNECTIONS periodically for tightness, especially the bulb connections and other leads in the DC circuit.

THE XENON LAMPHOUSE requires no lubrication other than the blower motor. This should be lubricated with two or three drops of non-detergent oil at each oil hole every six months. The lamphouse cover must be removed to expose the oil holes.

THE XENON BULB should be checked occasionally for presence of foreign material on the quartz envelope. Any dirt or other foreign material must be removed immediately. **CAUTION:** Observe all safety procedures when working around the exposed bulb.

THE INSIDE OF THE LAMPHOUSE and the blower should be cleaned periodically, depending on the dust conditions at each installation. The blower requires cleaning to remove dust build up which accumulates over a period of time. Keep the air inlet grille clean to permit free air flow.

AN ARC STABILIZATION MAGNET is mounted to the base of the lamphouse below the reflector and is required by xenon bulb manufacturers for the correct operation of the 2000 watt horizontal bulb. If removed for any reason, it must be replaced with the NORTH seeking pole (unpainted) toward the right (operator's) side of the lamphouse. The presence of this magnet is not detrimental to the operation of 1000 or 1600 watt bulbs, if used in place of the 2000 watt bulb.

THE OPTICAL SYSTEM LENSES must be kept clean to prevent any light reduction in the projected spot. To gain access to the lenses, tighten the horizontal swing and vertical tilt locking clamps, and remove the color boomerang and optical system housing.

CLEAN THE PROJECTION LENS and large lens with any cleaner approved for use on coated projection lenses. If the projection lens is removed for cleaning, note the direction of the lens when reinstalling. The lens tube is marked with arrows indicating the end nearest the iris.

WHEN TRANSPORTING the spotlight, it is recommended that the xenon bulb be removed and placed in its original shipping carton with the cover on to insure against breakage. If the spotlight is equipped with the standard 2 kW bulb shock mount, the unit may be transported with the bulb installed, assuming reasonable caution is exercised. Under *no* circumstances should the unit be moved until the bulb has cooled to room temperature.

LAMPHOUSE SCHEMATIC

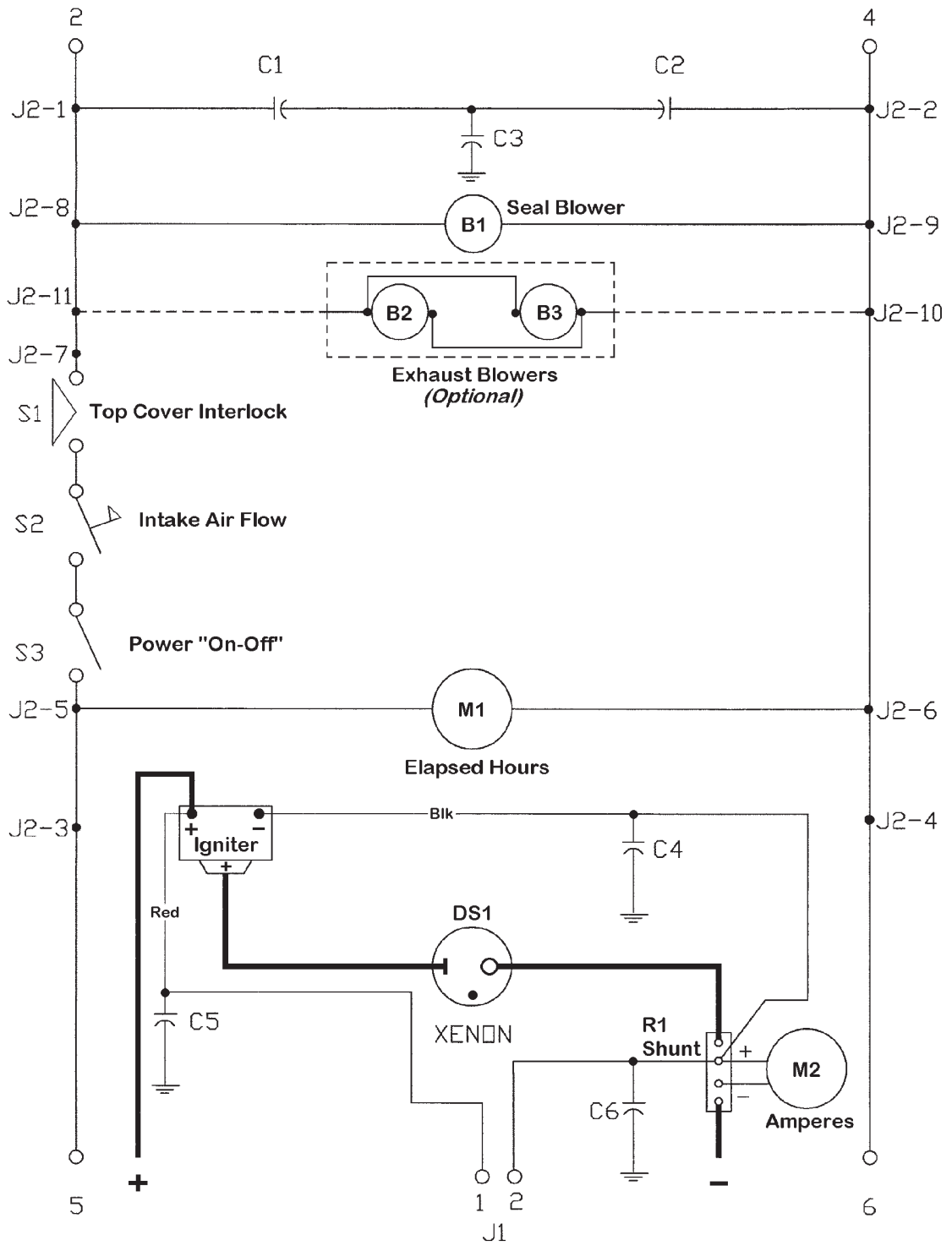

SCHEMATIC DIAGRAM
Parts List

Ref.		
<u>Desig.</u>	<u>Part No.</u>	<u>Description</u>
B1	7201038	Blower, 115 V.AC, 50/60 Hz.
B2,3	6198002	Blower, 115 V.AC, 50/60 Hz. (optional)
C1,2	76132000	Capacitor, .005 μ f, 600 WVDC
C3	76133000	Capacitor, .01 μ f, 400 WVDC
C4,5	6108075	Capacitor, 1.0 μ f, 630 WVDC
C6	79127000	Capacitor, .01 μ f, 1000 VDC
-	7201033	Capacitor PC Board Assembly (C1-C6)
DS1	-	Xenon Bulb (by Customer)
M1	7132002	Elapsed Time Meter, 50/60 Hz.
M2	7132001	Ammeter, 0-100 A.
R1	7198022	Shunt, 100 A. 50 mV.
S1	80168000	Cover Interlock Switch
S2	85106000	Air Flow Switch
S3	2161228	Rocker Switch, ON-OFF
-	65503000	DC Pulse Igniter Assembly
-	65858000	Igniter Case & Coil Assembly
-	25476000	Igniter Printed Circuit Board Assembly
-	7201031	Lamphouse/Power Supply Interconnect Cable (includes 88318000 MS Connector & 62151000 Clamp)

Specify Equipment Type and Serial Number when ordering replacement parts.

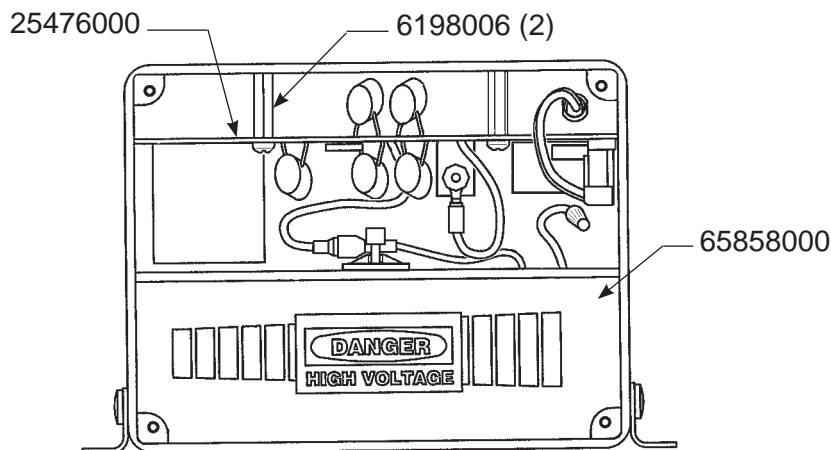

65503000 Igniter (detail); also see Figure 2, Item 9

TROUBLE CHART

NORMAL OPERATION

WHEN THE SWITCH in the main AC supply line to the xenon power supply is in the ON position, and the 30 A. circuit breaker on the switching power supply is ON, the green 20 VDC, VIN, and FUSE lights on the xenon power supply will glow. The lamphouse blower will start.

OPERATION OF THE LAMPHOUSE BLOWER will close the air flow interlock switch, and assuming the lamphouse top cover is correctly installed and secured, the control circuit to the LAMP switch will be completed.

WHEN THE “LAMP” SWITCH is placed in the ON position, the AC control circuit in the lamphouse will energize the power supply circuitry providing DC current to the igniter and bulb. The green GO power supply indicator light will glow, and high “no load” (open circuit) DC voltage will be applied to the DC pulse igniter.

THERE WILL BE a distinctly audible high voltage arc ping at the igniter arc gap and across the bulb electrodes. The bulb should ignite immediately after one or two of these high voltage pulses, and the lamp current will adjust to the output setting of the xenon power supply. Multiple ignition pulses prior to bulb ignition normally indicate a low DC output setting. See xenon power supply manual. A “warm” or aged xenon bulb might also require multiple strikes.

TROUBLE SHOOTING

IF THE XENON BULB does not ignite, observe the following operational sequences for assistance in locating and isolating the trouble area.

WHEN THE FANS and the green indicator lights on the power supply are on, the AC circuit in the power supply is trouble-free up to the terminal block in the power supply.

AT THIS TIME, the lamphouse blower should operate. If this does not occur, the trouble is located in the blower motor, a loose J2 connection, or a broken #2 or #4 lead (MS connector pins “C” and “E”). **CAUTION:** To prevent bulb ignition when checking the AC control circuit in the lamphouse, temporarily unplug J1 (two-pin plug) from the lamphouse printed circuit board. Check at this time for **115 V.AC Control Voltage** at the interlock switches (wires J2-10 & J2-5) and the blower terminals (J2-8 & J2-9). Replace DC plug J1 before proceeding.

THE VANE on the air flow switch should raise. With the LAMP switch in the “ON” position, the running time meter should start and indicate elapsed time. If this meter does not operate, check for continuity through the LAMP switch.

TROUBLE SHOOTING (continued)

A DEFECTIVE RUNNING TIME METER will *not* prevent bulb ignition.

WITH THE “LAMP” SWITCH in the “ON” position, a distinct high voltage arcing should be heard at the spark gap in the igniter, and the flash of the xenon bulb should be visible through the ammeter as a high DC voltage pulse is applied across the bulb electrodes.

IF THE HIGH VOLTAGE PING or the flash at the ammeter is not apparent, check the “No Load” DC voltage between the lamphouse and power supply. Measure the DC voltage across terminals J1-1 (+) and J1-2 (-). DO NOT measure voltage across the bulb end caps. A reading of 130-170 V.DC should be measured. If this voltage is not indicated, the problem is in the leads between the lamphouse and power supply, the MS connectors, or in the power supply boost circuit. See the trouble shooting section of the xenon power supply manual for additional instructions.

IF THE HIGH VOLTAGE ARC is audible at the lamphouse and the bulb does *not* flash, check for a lamphouse DC lead arcing to ground. If no ground fault is detected, replace the bulb and attempt ignition with the new bulb.

IF THE HIGH VOLTAGE ARC is audible at the lamphouse, the flash of the bulb is visible in the ammeter, but ignition of the bulb is not sustained, the problem area is in the power supply. See the trouble shooting section of the power supply manual for additional instructions.

IF THE HIGH VOLTAGE ARC is *not* audible or the flash of the bulb visible, and DC “no load” voltage exceeds 130 V.DC, the problem is in the igniter assembly.

EXCHANGE of components (i.e. igniters, igniter PC boards) between similar Strong Xenon Super Troupers to aid in diagnosis of a problem is encouraged. This will not lead to equipment damage, and will not void equipment warranty.



CAUTION - HIGH VOLTAGE



THE STRONG DC PULSE IGNITER STORES ENERGY IN ITS CAPACITORS AFTER THE UNIT HAS BEEN DE-ENERGIZED. TO PREVENT SHOCK, THIS ENERGY CAN BE DISCHARGED BY PLACING THE BLADE OF AN INSULATED-HANDLE SCREWDRIVER ACROSS THE TIPS OF THE TWO SPARK GAP SCREWS MOUNTED TO THE IGNITER PC BOARD.

XENON SUPER TROUPER TROUBLESHOOTING

Bulb fails to ignite.

1. AC power not on to lamphouse. Turn switching power supply 30 A. circuit breaker ON. If 115 V.AC not read at J2-1 & J2-2, see power supply manual.
2. Top cover switch (S1) open. Close and secure lamphouse top cover. Tighten all four retaining screws; check switch actuating screw.
3. Faulty interlock switch(s). Check for 115 V.AC at J2-5 & J2-6; replace switch(s) if defective.
4. Air vane switch S2 not closing. Check for unobstructed operation; clean if required. Check continuity between “NO” and “COM;” replace if defective.
5. Faulty S3 “ON-OFF” switch. Check for continuity through switch; check for loose terminals or wiring. Replace if defective.
6. Igniter arc gap too wide. Open igniter case, discharge capacitors, and shorten the gap between the (2) arc gap screws on the PC board.

Bulb fails to ignite; ping audible, bulb flash visible.

1. Inadequate DC output from xenon power supply. Set power supply output to correct range required for bulb wattage (65 A. for 1.6 kW, 75 A. for 2 kW).
2. Igniter arc gap too short. Open igniter case, discharge capacitors, and widen the gap between the (2) arc gap set screws on the PC board.
3. Faulty or expired xenon bulb. Replace as required.

Bulb fails to ignite; ping audible, no bulb flash.

1. Faulty xenon bulb. Check for cracked electrodes or darkened envelope. Replace if defective.
2. Ignition pulse shorting to ground. Inspect DC leads for burned insulation; dress leads away from grounded metal components.

No high voltage ping audible, LAMP switch in “ON.”

1. Loss of AC control voltage. Check xenon power supply for tripped circuit breaker or open thermal switch. See power supply manual.
2. Little or no DC “No Load” voltage. Measure DC “No Load” voltage at J1-1 & J1-2. See power supply manual.
3. Open fuse (15 A.) in power supply primary module. SEE POWER SUPPLY MANUAL. Allow (10) minutes for capacitor discharge before replacing.
4. Defective spark gap. Open igniter case, discharge capacitors, and reduce arc gap; or replace igniter PC board as required.
5. Faulty igniter. Check for adequate DC “No Load” (130-180 V.DC) at J1-1 & J1-2. If present, and igniter does not fire, replace igniter.

Bulb goes out during operation.

1. Xenon power supply overheated; thermal switch open. Check power supply blower(s), air inlets and outlets for free air flow. See power supply manual.
2. Xenon bulb depressurizing. Check for envelope discoloration; replace if defective.
3. Lamphouse blower B1 not moving adequate air. Clean and lubricate blower.
4. Lamphouse blower B1 failed or obstructed. Clean dust and dirt from blower inlet grille. Check for 115 V.AC at J2-8 & J2-9; replace blower if defective.
5. Lamphouse air vane switch S2 faulty. Check for vane actuation; adjust or replace as required.
6. Power supply brown-out protection actuated by voltage drop. See power supply manual.
7. Phase loss detected by power supply (3 phase units only). See power supply manual.

Power supply does not energize when actuated.

1. S1 cover interlock switch, B1 blower, S2 air vane switch, S3 power switch. Check for 115 V.AC at each station; replace defective component.

SEE POWER SUPPLY TROUBLESHOOTING UNDER SAME HEADING.

Noise in theatre sound as bulb ignites.

1. Faulty RF suppression capacitor(s). Remove and test C1, C2, C3, C4, C5 or C6. Replace if defective. NOTE: replacement 7201033 PC board includes *all* capacitors.
2. Lamphouse, power supply, or sound system not properly grounded. Connect to adequate earth ground.
3. Leads between lamphouse and automation contact not shielded. Shield leads in conduit.

Excessive light flicker.

1. Faulty or aged bulb. Check for cracked or sagging electrodes; replace if defective.
2. Excessive ripple in DC output. See power supply manual.
3. Arc stabilization magnet missing or reversed. NORTH (unpainted) pole should point toward operator side. Check with compass if required.
4. Bulb seal leakage. Check bulb envelope for blue/white discoloration; replace as required.

Reduced light output.

1. Normal bulb aging. Increase output current. DO NOT EXCEED MAXIMUM CURRENT SPECIFIED BY BULB MANUFACTURER.
2. Soiled reflector. Clean using commercial glass cleaner. USE NO ABRASIVES.
3. Soiled heat filter, projection lens or large lens. Clean as required.
4. Bulb seal leakage. Check bulb envelope for blue/white discoloration; replace as required.

Extremely long duration between ignition pulses.

1. Low DC “No Load” (open circuit) voltage from xenon power supply. Check “No Load” voltage; see power supply manual.
2. Defective spark gap. A “Ping” sound is normal; excessive “Hissing” is abnormal. Adjust or replace if defective.
3. Low AC voltage to lamphouse. Check for 115 V.AC at J2-1 & J2-2; if below 95 volts, check stepdown or isolation transformer in xenon power supply. See power supply manual.

Color gels burning or fading prematurely.

1. Bulb focused to “hot spot.” Refocus bulb to flat field with iris fully open and spot size control handle (“trombone”) fully forward.
2. Heat filter glass reversed or peeled. Check for coated surface *toward* bulb; replace if coating peeled.
3. Reflector coating peeled. Replace if defective.

NOTICE

The Strong switching-type Xenon Power Supply employs solid state circuitry requiring sophisticated diagnostic equipment not generally available to field service personnel. If an ignition problem in the TROUBLE CHART section is traced to this unit, contact an authorized Strong Dealer for further information.

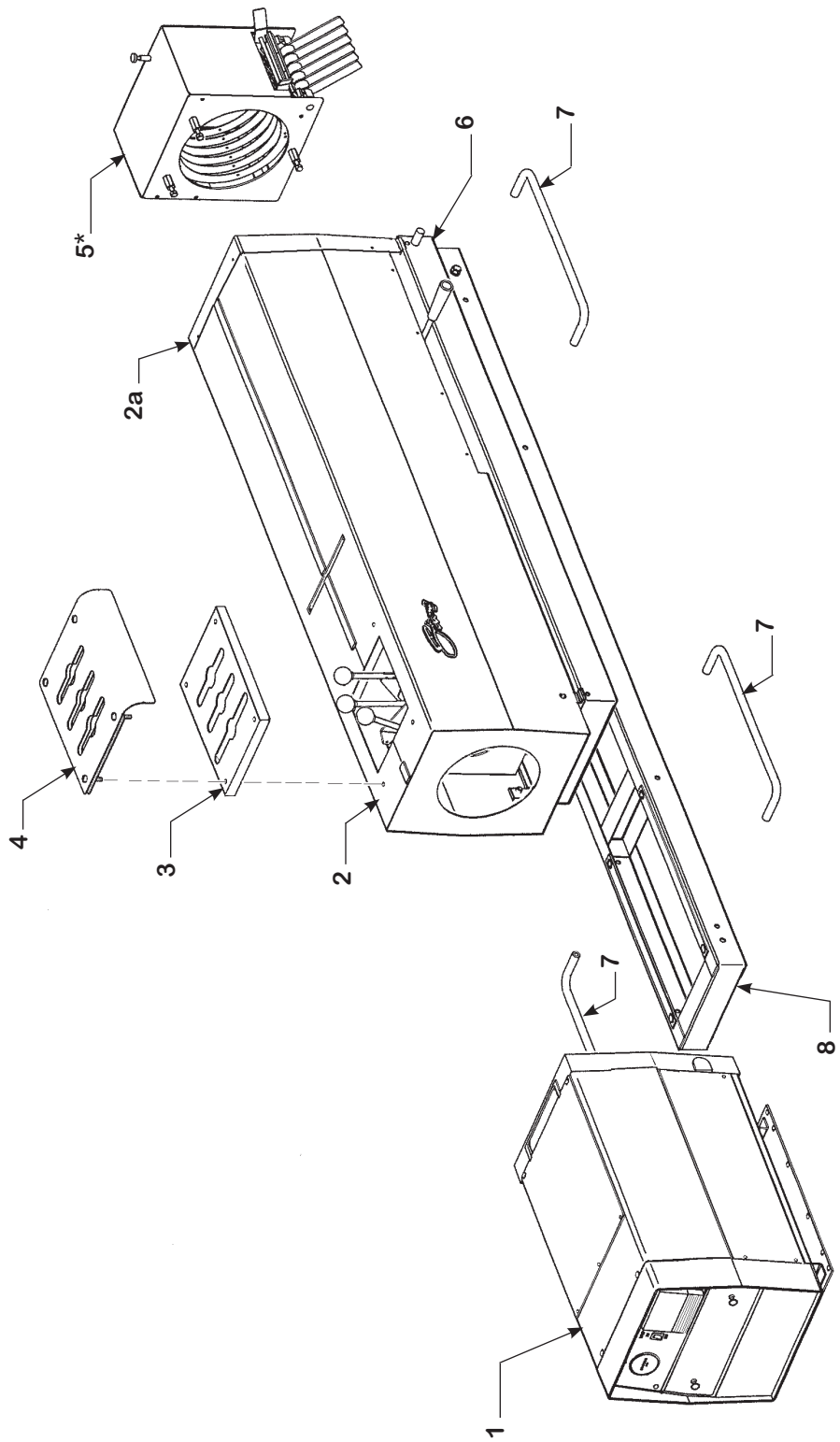

* Optional

FIGURE 1

PARTS LIST

Figure 1

<u>Item</u>	<u>Part No.</u>	<u>Description</u>
1	7201039	Lamphouse Assembly (see Figures 2 & 3)
-	4250503	Mounting Screw, 1/4-20 x 1/2" Hex Head
-	4257102	Flatwasher, 1/4"
-	4257001	Lockwasher, 1/4"
-	4258001	Hexnut, 1/4-20
2	7201150	Lens Mechanism Housing Assembly (see Figure 4, Item 29)
-	7201050	Housing, Welded Assembly
-	83102100	Chrome Trim, Short
-	83102200	Chrome Trim, Long
-	83103000	Spring Clip (Trim Mount)
-	83777000	Side Light Baffle, Rubber
-	83782000	Rear Light Baffle, Rubber
2a	83327000	Front Edge Trim, Black
3	83328000	Cover Plate, Beam Shape Control Levers
4	3200617	Heat Guard Plate
-	3156002	Mounting Spacer, 1/4" Diameter x 1/4"
-	3200630	Light Baffle, Black Rubber
-	3200629	Baffle Retaining Plate
-	4251253	Mounting Screw, 1/4-20 x 1-1/4" Pan Head
5	7201110	Color Boomerang Assembly (<i>optional</i> ; see Figure 7)
6	7201155	Lens Mechanism Assembly (see Figures 4 & 5)
-	4250623	Mounting Screw, 1/4-20 x 5/8" Hex Head
-	4257102	Flatwasher, 1/4"
-	4258007	Locknut, 1/4-20
7	49342000	Handle, Base Rail
-	4310500	Mounting Screw, 5/16-18 x 1/2" Hex Head
-	4317000	Split Lockwasher, 5/16"
8	7201153	Base Rail Welded Assembly
-	4310753	Mounting Screw, 5/16-18 x 3/4" Wing Head
-	4317001	Lockwasher, 5/16"
-	4317102	Flatwasher, 5/16"

Item 27 Plate may be replaced by *optional*
7201222 Plate with Exhaust Stack.

See Figure 8 for *optional* 7201036
Exhaust Blower Assembly0.

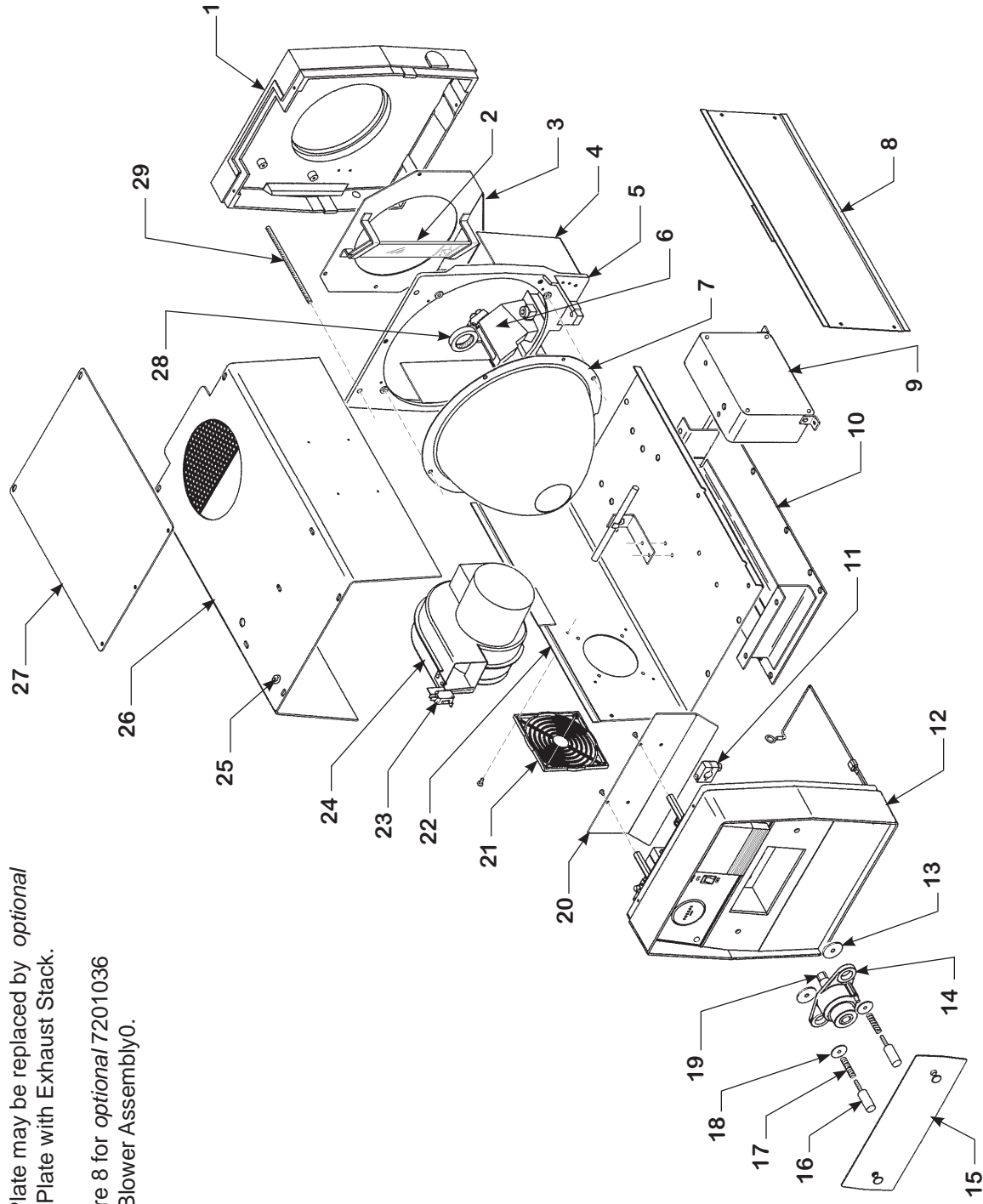

FIGURE 2

PARTS LIST

Figure 2

<u>Item</u>	<u>Part No.</u>	<u>Description</u>
1	39115000	Front Casting
2	65122A00	Heat Filter, Dichroic Glass
3	65933000	Heat Filter Mounting Bracket, Welded Assembly
-	4110250	Mounting Screw, 10-24 x 1/4" Fillister Head
-	4107001	Lockwasher, #10
4	65156000	Heat Shield, Right
-	65155000	Heat Shield, Left
-	4080310	Mounting Screw, 8-32 x 5/16" Pan Head
5	65114000	Reflector Bulkhead Casting
-	4250752	Mounting Screw, 1/4-20 x 3/4" Hex Head
-	4257000	Split Lockwasher, 1/4"
-	4258001	Hexnut, 1/4-20
6	65115000	Air Duct Casting
-	65171000	Insulated Bushing
-	65175000	Insulator Plate
-	4081002	Screw, 8-32 x 1" Pan Head
-	4087004	Flatwasher, #8
7	23756000	Dichroic Reflector, 10" Diameter, Flanged
-	4250505	Mounting Screw, 1/4-20 x 1/2" Socket Head
-	4257004	Lockwasher, 1/4"
8	65864000	Igniter Access Panel
-	410050B	Mounting Screw, 10-32 x 1/2" Pan Head
9	65503000	DC Pulse Igniter Assembly
-	65858000	Igniter Case & Coil Assembly
-	65387000	Mounting Foot (incl. with 65858000)
-	4250250	Screw, 1/4-20 x 1/4" Nylon Pan Head
-	25476000	Igniter Printed Circuit Board Assembly
10	65969000	Lamphouse Base Adapter Assembly
-	4250503	Mounting Screw, 1/4-20 x 1/2" Hex Head
-	4257102	Flatwasher, 1/4"
-	4257001	Lockwasher, 1/4"
11	65966000	Igniter Clamp & Lead Assembly
-	65131000	Contact Clamp
-	4080870	Clamping Screw, 8-32 x 7/8" Socket Head
12	7201029	Rear Casting Assembly (see Figure 3)
13	65197000	Spacer Washer

PARTS LIST, Figure 2 (continued)

<u>Item</u>	<u>Part No.</u>	<u>Description</u>
14	65840000	Bulb Positioning Mechanism (see Detail on Page 32)
15	65968000	Rear Cover Panel Assembly
-	65140000	Cover Plate
-	65166000	Plunger, Black Plastic
-	65167000	Grommit, Black Plastic
16	37985000	Thumbscrew
17	15010000	Compression Spring
18	65150000	Fender Washer
19	65844000	Collet Assembly, 2 kW (incl. with Item 14)
-	2148027	Snap Ring (incl. with Item 14)
20	7201037	Light Shield, Circuit Board
-	4060372	Mounting Screw, 6-32 x 3/8" Pan Head
21	83131000	Blower Intake Grille
-	4080375	Mounting Screw, 8-32 x 3/8" Pan Head
22	65865000	Base Pan, Welded Assembly
-	39215000	Arc Stabilization Magnet
-	65409000	"L" Bracket, Magnet
-	4110004	Magnet Clamp
23	85109000	Air Flow Switch (S2)
-	4040750	Mounting Screw, 4-40 x 3/4" Pan Head
-	65158000	Switch Mounting Bracket (incl. with Item 24)
24	7201038	Blower Assembly (B1), 115 V.AC, 50/60 Hz.
-	4080506	Mounting Screw, 8-32 x 1/2" Pan Head
25	4110621	Actuating Screw, Cover Interlock Switch
-	4118001	Locknut, 10-24
26	7201024	Lamphouse Top Cover, Welded Assembly
-	4100502	Mounting Screw, 10-32 x 1/2" Tamperproof (Holt Head)
-	4107101	Flatwasher, #10
-	65149A00	Screwdriver for 4100502 (Holt Head)
27	7201026	Exhaust Cover Plate (<i>as shown</i> ; 7201222 with Exhaust Stack))
-	4100374	Mounting Screw, 10-32 x 3/8" Pan Head
-	4108007	Locking Hexnut, 10-32
28	83747000	Cathode Shock Mount Assembly, 2 kW
-	83748000	Ring Assembly
-	83410000	Coil Spring, Shock Mount
-	4100620	Clamping Screw, 10-32 x 5/8" Socket Head
-	83364000	Base Mount Bracket
29	65164000	Reflector Tie Rod (Factory Set - Do Not Adjust)
-	4258001	Hexnut, 1/4-20

FIGURE 3

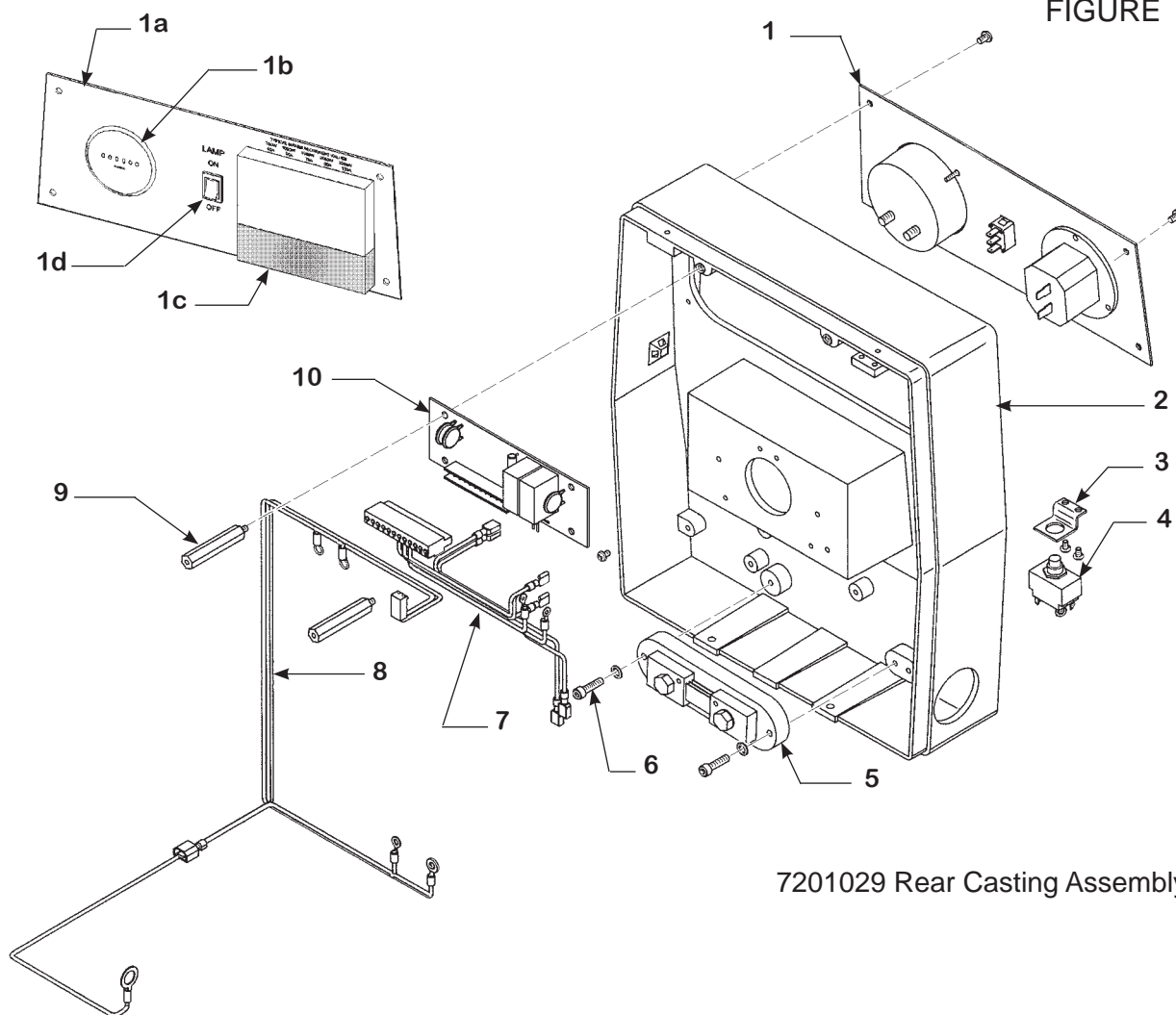

7201029 Rear Casting Assembly

<u>Item</u>	<u>Part No.</u>	<u>Description</u>
1	7201028	Instrument Panel Assembly
-	408025D	Mounting Screw, 8-32 x 1/4" Pan Head
1a	7201027	Plate (less components)
1b	7132002	Elapsed Hour Meter (M1)
1c	7132001	Ammeter (M2), 0-100 A.
1d	2161228	Rocker Switch (S3), LAMP "On-Off"
2	65112000	Lamphouse Rear Casting
-	81143000	Cable Clamp, 90° (not shown)
3	65185000	Switch Mounting Bracket
-	4040750	Screw, 4-40 x 3/4" Pan Head
4	80168000	Top Cover Interlock Switch (S1)

PARTS LIST, Figure 3 (continued)

<u>Item</u>	<u>Part No.</u>	<u>Description</u>
5	7198022	Shunt (R1), 100 A. 50 mV.
-	65948000	DC Lead, Shunt to Cathode Clamp, 29" (not shown)
6	4110750	Screw, 10-24 x 3/4" Socket Head (2 req'd.)
-	4107001	Lockwasher, #10
7	7201034	Wire Harness, AC Circuit (with J2)
8	7201035	Wire Harness, DC Circuit (with J1)
9	4198036	Stand Off, 2" Hex Aluminum, Thrd. 8-32 (2 req'd.)
-	4087000	Lockwasher, #8
10	7201033	Printed Circuit Board Assembly, Capacitors (C1-C6)

NOT SHOWN

7201031	Interconnect Cable, Lamphouse to Power Supply
88318000	MS Connector, (14) Pin Male (incl. with 7201031)
62151000	Clamp, MS Connector (incl. with 7201031)
81143000	Interconnect Cable Strain Relief Clamp, 90°

65840000 Bulb Adjustment Assembly (see Figure 2, Item 14)

- 37985000 Thumb Screw (2 req'd.)
- 15010000 Compression Spring (2 req'd.)
- 65116000 Casting, Adjustment Mechanism
- 65150000 Fender Washer (2 req'd.)
- 65153000 Focus Lockscrew
- 65154000 Nylon Locking Ball
- 65959000 Focus Screw & Bearing Assembly
- 2148027 Snap Ring, Collet Retaining
- 65844000 Collet, 2 kW
- 65960000 Collet, 1, 1.6 kW (optional)

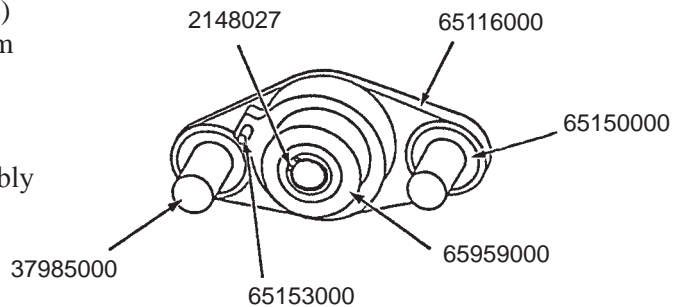

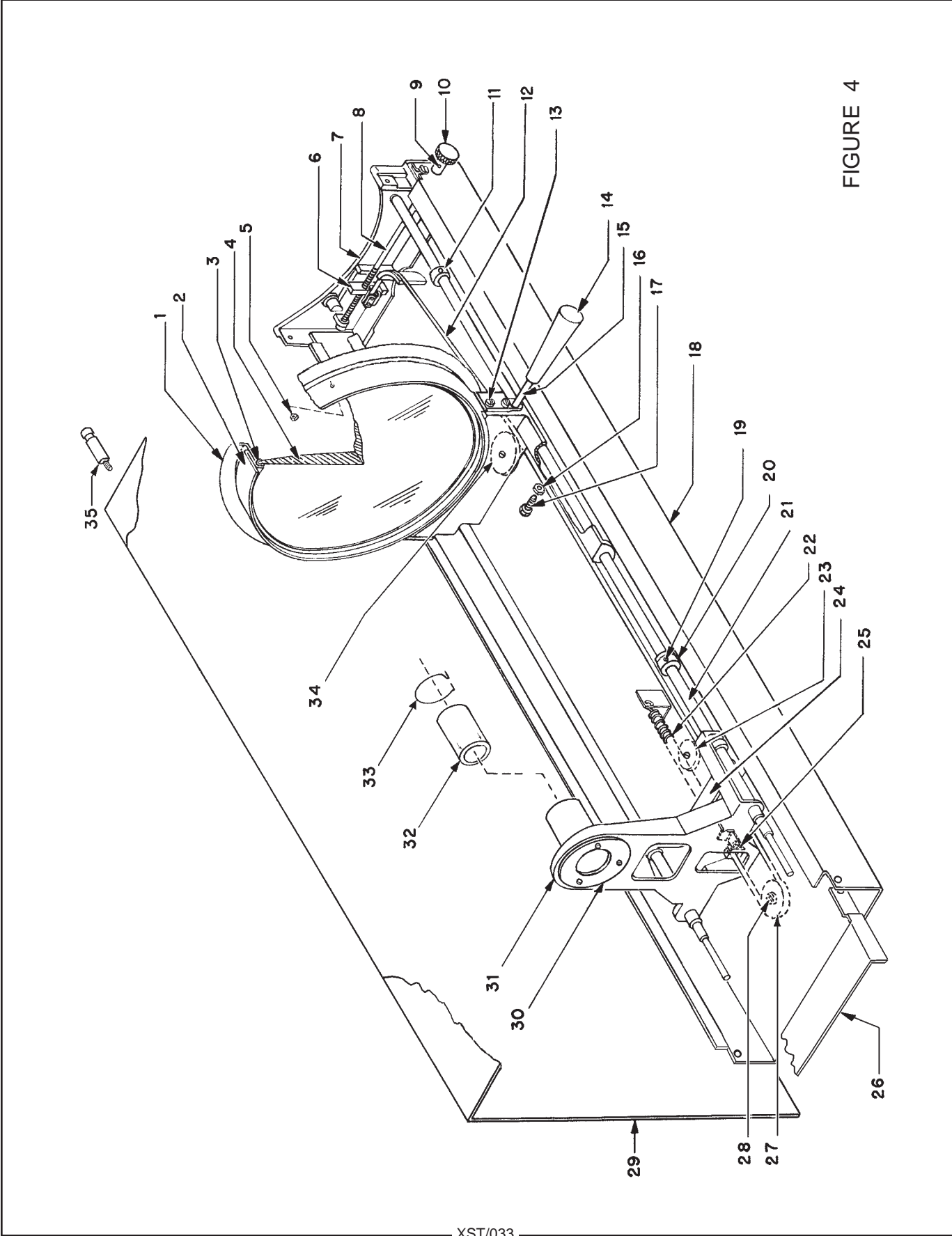

FIGURE 4

PARTS LIST

Figure 4

<u>Item</u>	<u>Part No.</u>	<u>Description</u>
1	83309000	Lens Retainer Spinning (pre-1981 units)
2	83864000	Lens Ring, Welded Assembly *
-	83107000	Lens Retaining Ring *
3	83306000	Rubber Gasket, Large Lens *
4	83302000	Large Lens *
*	83775000	Large Lens & Ring Assembly (All above parts marked *)
5	4060250	Screw, 6-32 x 1/4" Pan Head
6	51133000	Block, Lens Focus
7	51352000	End Casting, Front
8	51454000	Focus Adjusting Screw
9	4080120	Set Screw, Focus Knob
10	51168000	Focus Adjusting Control Knob
11	51114000	Stop Collar & Set Screw
12	51910000	Focus Adjusting Ribbon Assembly
13	4100371	Screw, 10-32 x 3/8" Pan Head
-	83863000	Large Lens Carriage Casting
14	51509000	Handle
15	51441000	Shaft, Trombone
-	2148011	Retaining Ring
16	4258015	Hexnut, 1/4-20 Nylon
17	4251001	Friction Brake Screw, 1/4-20 x 1" Hex Head Nylon
18	83789000	Base Pan, Lens Mechanism
19	4100180	Set Screw, 10-32 x 3/16" Cup Point
20	51114000	Stop Collar & Set Screw
-	51479000	Rubber Bumper
21	51453000	Slide Rod
-	48127000	Retaining Ring, Slide Rod
22	51162000	Expansion Spring, Focus Adjusting Ribbon
23	51158000	Pulley, Small
24	51354000	Slide Rod Support Casting
25	51120000	Spring & Ribbon Clip
26	7201154	End Cover, Light Shield
27	83163000	Pulley, Rear (see Figure 5, Item 12)
28	51160000	Pulley Stud (see Figure 5, Item 11)
29	7201150	Lens Mechanism Housing, Complete (see Figure 1, Item 2)
-	7201050	Lens Mechanism Housing, Welded Assembly
-	83328000	Slotted Top Cover Plate, Control Shafts
-	83777000	Rubber Light Shield, Trombone Shaft
-	83327000	Front Trim Frame, Mechanism Housing
-	83102100	Chrome Trim, Short (Fastener Clip: 83103000)
-	83102200	Chrome Trim, Long (Fastener Clip: 83103000)

PARTS LIST, Figure 4 (continued)

<u>Item</u>	<u>Part No.</u>	<u>Description</u>
30	83144000	Support Tube, Projection Lens
31	83160000	Rear Lens Carriage Casting
32	44239C00	Projection Lens (direct arrows on lens barrel toward lamp)
33	83155000	Lens Retaining Ring
34	47210000	Pulley, Large Lens Carriage
35	4198099	Boomerang Mounting Stud (<i>optional</i> ; see Figure 7, Item 16)
-	4250508	Boomerang Mounting Screw, 1/4-20 x 1/2" (3 req'd.)

FIGURE 5

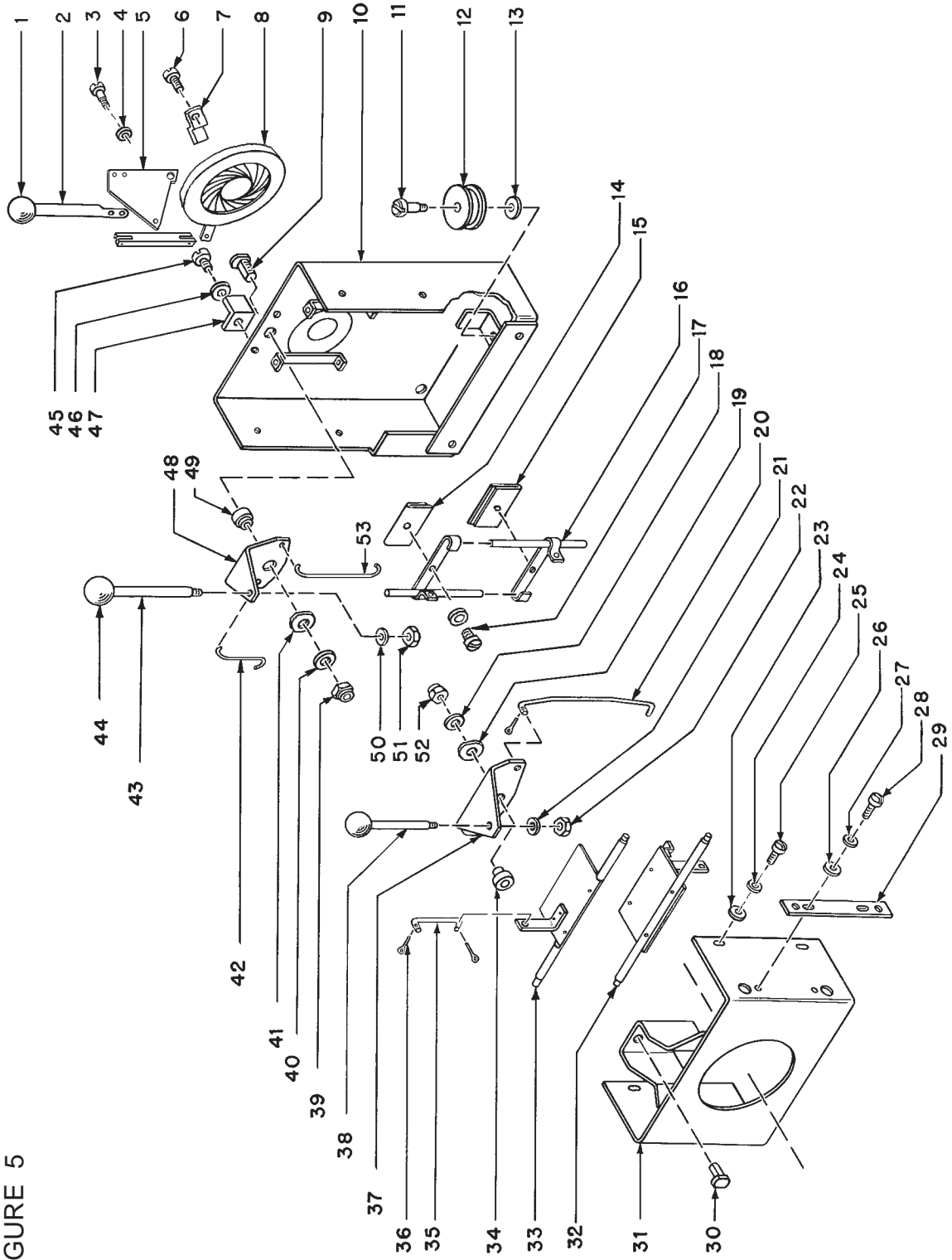

PARTS LIST

Figure 5

<u>Item</u>	<u>Part No.</u>	<u>Description</u>
1	10048A00	Knob
2	51451000	Shaft, Iris Handle
3	4151530	Shoulder Screw
4	25017000	Bushing
5	24369000	Bell Crank
-	7200075	Linkage Bar (to Item 8 Iris; see Figure 5A)
6	4080621	Screw, 8-32 x 5/8" Pan Head
7	25034000	Iris Clamp
8	24374000	Iris, 4" Diameter
-	24372000	Adapter "C" Ring (not shown; see Figure 5A)
9	51226000	Stud, Chopper Blade
10	83773000	Aperture Support Plate
11	51160000	Pulley Stud (see Figure 4, Item 28)
12	83163000	Pulley, Rear (see Figure 4, Item 27)
13	4087100	Washer, #8
14	47191000	Chopper Blade
15	47191000	Chopper Blade
16	47982000	Chopper Blade Slide Assembly (2 req'd.)
17	4080181	Screw, 8-32 x 3/16" Pan Head
-	4087004	Lockwasher, #8
18	4257102	Washer, 1/4" S.A.E.
19	4507106	Friction Washer
20	83134000	Pull Rod, Lower Fade-Out Blade
21	4257000	Lockwasher, 1/4" Split
22	4258001	Hex Nut, 1/4-20
23	4107100	Washer, #10, .036" Thick Brass
24	4107101	Lockwasher, #10
25	4100250	Screw, 10-32 x 1/4" Pan Head
26	4107100	Washer, #10, .036" Thick Brass
27	4107001	Lockwasher, #10
28	4100250	Screw, 10-32 x 1/4" Pan Head
29	83351000	Retainer Plate, Fade-Out Pivots
30	51226000	Pivot Stud, Fade-Out Control
31	83890000	Fade out Bracket, Welded Assembly
32	83892000	Lower Fade-Out Blade Assembly
33	83891000	Upper Fade-Out Blade Assembly

PARTS LIST, Figure 5 (continued)

<u>Item</u>	<u>Part No.</u>	<u>Description</u>
34	51153000	Spacer Bushing, Fade-Out Control
35	83133000	Pull Rod, Upper Fade-Out Blade
36	00919000	Cotter Pin, 1/16" x 1/2"
37	83143000	Fade-Out Control Bracket
38	51155000	Shaft Handle, Fade-Out Control
-	10048A00	Knob
39	4318004	Hex Nut, 5/16-18, Flexlock
40	4257102	Washer, 1/4" S.A.E.
41	4507106	Friction Washer
42	51498000	Chopper Pull Rod (Short)
43	51452000	Control Shaft, Choppers
44	10048A00	Knob
45	4080250	Screw, 8-32 x 1/4" Pan Head
46	4087004	Lockwasher, #8
47	47170000	Iris Stop (as shown)
48	51488000	Chopper Control Bracket
49	51153000	Spacer Bushing, Chopper Control
50	4257000	Lockwasher, 1/4" Split
51	4258001	Hex Nut, 1/4-20
52	4318004	Hex Nut, 5/16-18 Flexlock
53	51497000	Chopper Pull Rod (Long)

MAJOR SUBASSEMBLIES

83788000	Iris & Choppers Assembly
83790000	Fade-Out Assembly

<u>Part No.</u>	<u>Description</u>
2170029	Spring Washer
24369000	Bell Crank
24372000	Adapter Ring
24374000	Iris, 4" Diameter
25017000	Bushing (with 4151530)
25034000	Iris Clamp
4040310	Screw, 4-40 x 5/16"
406037B	Screw, 6-32 x 3/8"
4080621	Screw, 8-32 x 5/8"
4151530	Shoulder Bolt
51451000	Iris Control Handle
83773000	Aperture Support
7200075	Link
81432000	Shoulder Screw

FIGURE 5A

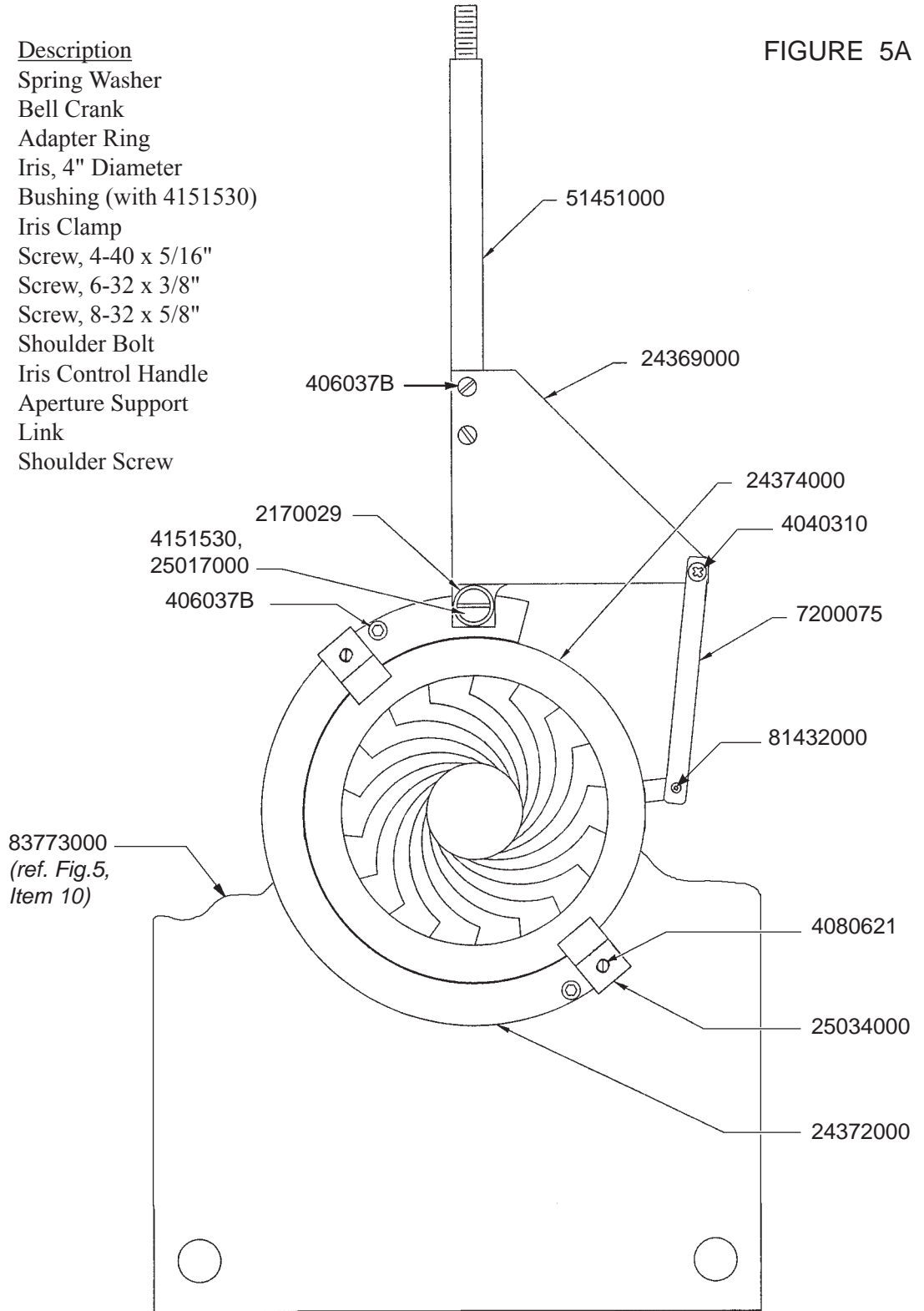
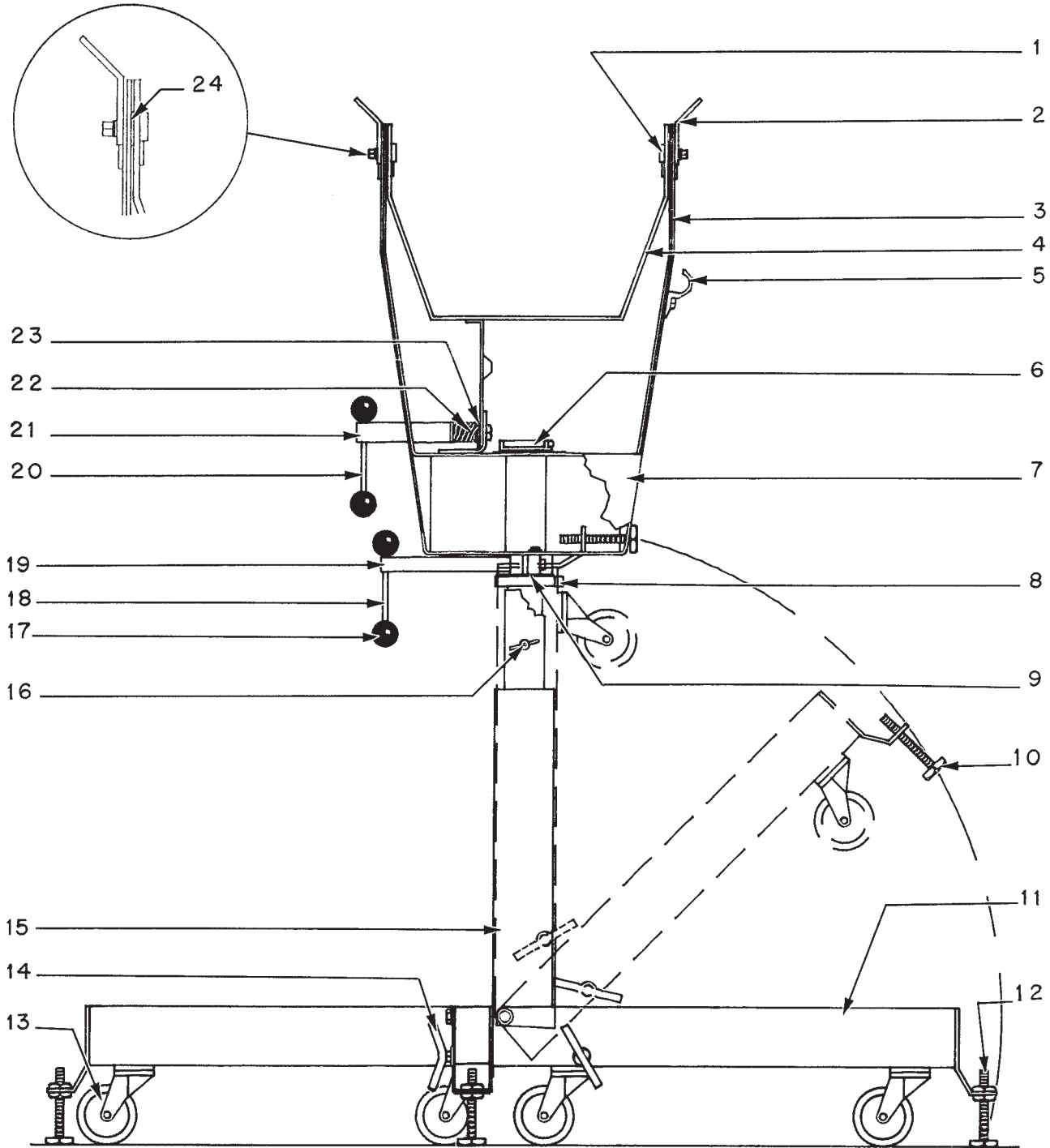

FIGURE 6



65826000 STAND & YOKE ASSEMBLY

PARTS LIST

Figure 6

<u>Item</u>	<u>Part No.</u>	<u>Description</u>
1	49120000	Tilt Axis Bolt
2	49943000	Lifting Strap
-	4378002	Hexnut, 3/8-16 NyLock
3	83743000	Yoke, Welded Assembly
4	49955000	Saddle & Quadrant, Welded Assembly
5	83341000	Cable Clamp
6	65431000	Inner Retaining Collar
-	65824000	Inner Tube Welded Assembly
7	83357000	Cover Panel
8	83381000	Swivel Clamp Collar
-	83386000	Thrust Bearing
-	83388000	Bearing Race
9	49291000	Swivel Stop Plate
10	49226000	Leveling Pad
11	83744000	Base Leg Welded Assembly
-	4433000	Bolt, 7/16-14 x 3" Hex Head
-	4438002	Elastic Stop Nut
-	4377103	Washer, 7/16"
12	49226000	Leveling Pad
13	49208000	Caster
14	83745000	T-Bolt Leg Pin, Welded Assembly
-	4377103	Washer, 7/16"
15	83742000	Base Support Column Welded Assembly
-	18765000	Folding Base Assembly (Items 10-15)
16	48395000	Height Adjusting Pin
17	10048A00	Knob
18	49130000	Handle, Swivel Lock
19	49290000	Swivel Lock Clamping Shaft
20	49130000	Handle, Tilt Lock
21	49223000	Tilt Lock Clamping Shaft
22	49125000	Compression Spring
-	49124000	Spring Bushing
23	7201021	Tilt Lock Clamping Plate
24	02411000	Spider Washer

NOT SHOWN

4310753	Thumb Screw, 5/16-18 x 3/4" (Head Mounting)
4317001	Lockwasher, 5/16"
4317102	Flatwasher, 5/16"

FIGURE 7

7201110 COLOR BOOMERANG
ASSEMBLY (optional)

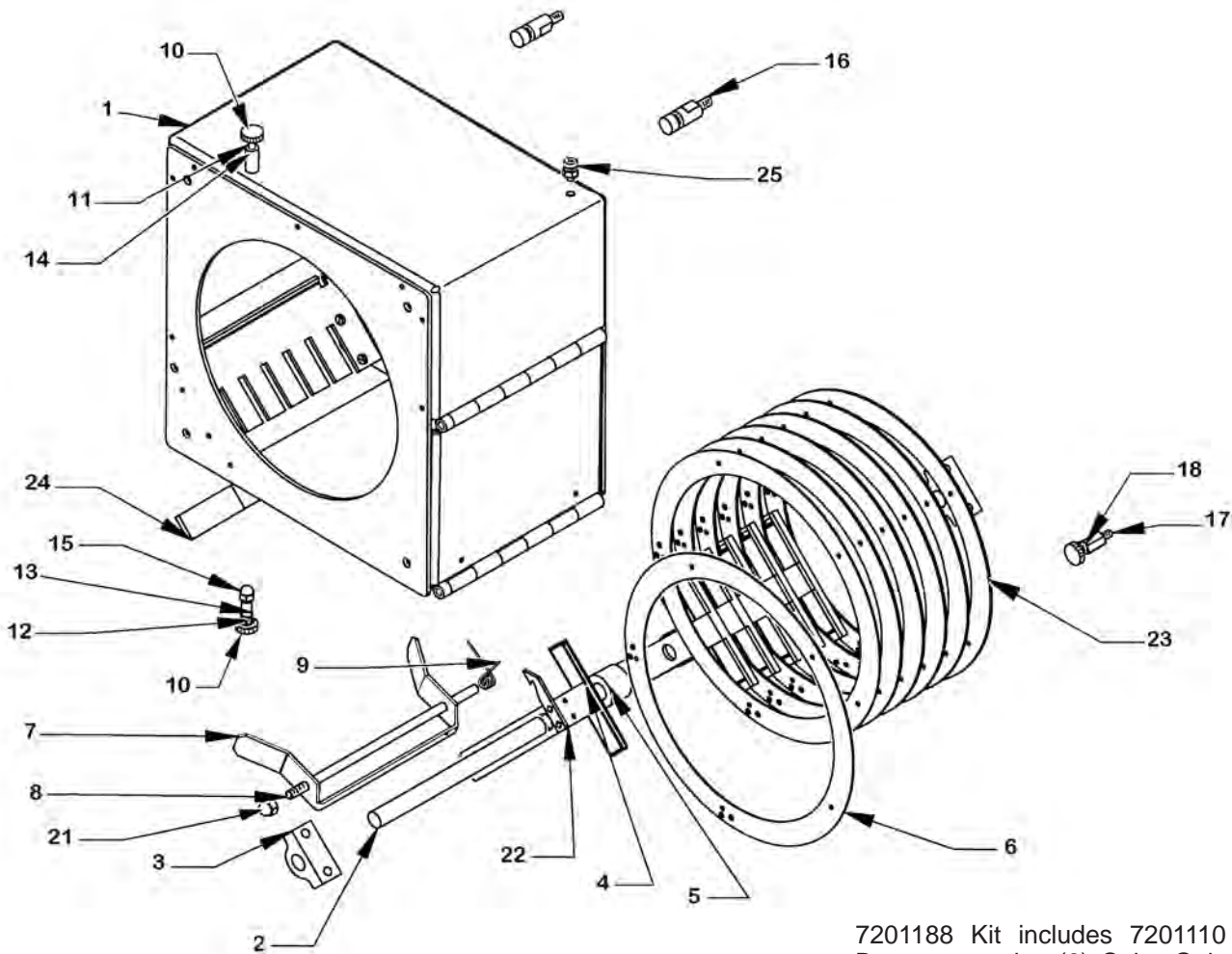

7201188 Kit includes 7201110
Boomerang plus (6) Color Gels
and (30) Fasteners

Item	Part No.	Description
1	7201058	Boomerang Housing Assembly
2	7201062	Color Arm Pivot Shaft
3	7200713	Bearing Block (2 req'd.)
4	7201061	Color Arm (6 req'd.)
5	7200911	Spacer (5 req'd.)
6	51376000	Color Disc Cover Plate (6 req'd.)
-	1456000	Brass Fastener (30 req'd.)
7	7200905	Color Release Lever
8	7200930	Release Lever Pivot Shaft
9	7158004	Torsion Spring
10	4151425	Thumb Screw Knob
11	4101501	Screw, 10-32 x 1-1/2" Socket Head

PARTS LIST, Figure 7 (continued)

<u>Item</u>	<u>Part No.</u>	<u>Description</u>
12	4101000	Screw, 10-32 x 1" Socket Head
13	3135012	Nutsert, 10-32 (2 req'd.)
14	7156001	Spacer, 3/8" Diameter x 3/4" Long
15	4088008	Acorn Nut, 10-32 (3 req'd.)
16	4198099	Standoff, 1" Long (mounts to Spotlight; 3 req'd.)
17	4198096	Hex Spacer, 3/4" Thrd. 10-32 (early models)
18	4107106	Bolt Retainer Push Nut
19	4100374	Screw, 10-32 x 3/8" Socket Head
20	3135014	Nutsert, 1/4-20
21	4258008	Acorn Nut, 1/4-20
22	51396000	Color Arm Catch Hook (6 req'd.)
-	4080250	Mounting Screw, 8-32 x 1/4" Pan Head (12 req'd.)
23	51928000	Color Disc Slide Channel (6 req'd.)
24	51505000	Rocker Pad (2 req'd.)
25	4100371	Screw, 10-32 x 3/8" Pan Head (secures Safety Cable)
26	4250508	Screw, 1/4-20 x 1/2" Pan Head (4 req'd.)

NOT SHOWN

7201220	Safety Cable
3200337	Clip, Safety Cable (mounts to Spotlight Base Rail)
3198643	Carabiner Clip, Safety Cable

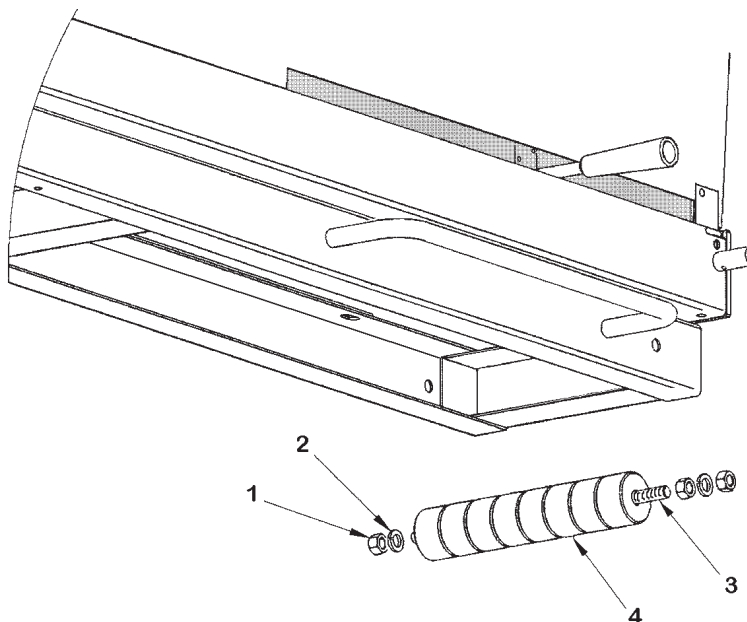

7201191 COUNTERWEIGHT ASSEMBLY (optional)

<u>Item</u>	<u>Part No.</u>	<u>Description</u>
1	4378001	Hexnut, 3/8-16
2	4377003	Lockwasher, 3/8"
3	2221120	Threaded Shaft
4	7200975	Weight Puck

FIGURE 8

7201036 EXHAUST BLOWER ASSEMBLY (optional)

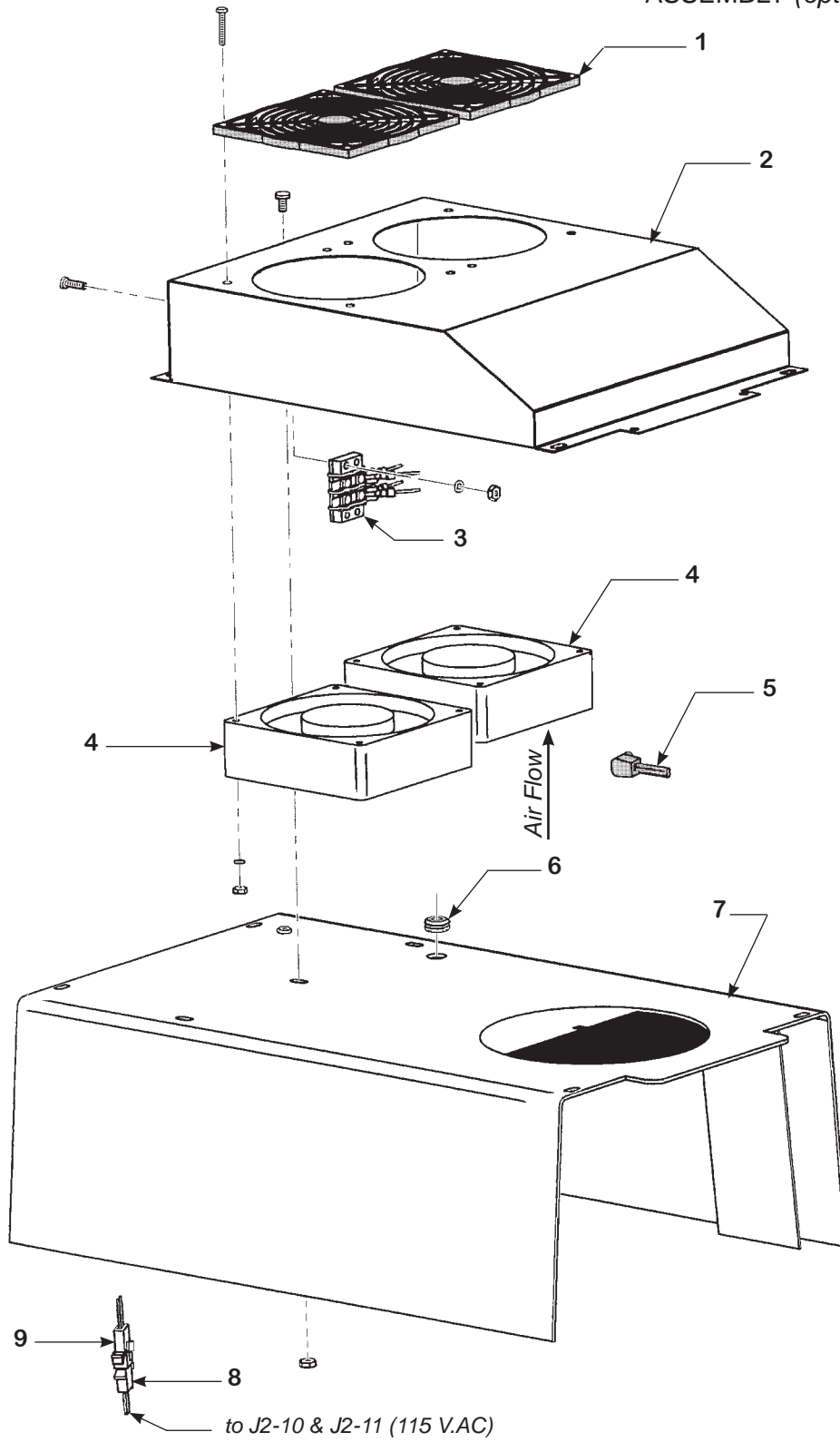

PARTS LIST

Figure 8

<u>Item</u>	<u>Part No.</u>	<u>Description</u>
1	83131000	Blower Intake Grille
-	4060870	Mounting Screw, 6-32 x 7/8" Pan Head
-	4170058	Lockwasher, #6
-	4068001	Hexnut, 6-32
2	39963000	Blower Hood, Welded Assembly
-	4100371	Mounting Screw, 10-32 x 3/8" Pan Head
-	4108007	Locknut, 10-32
-	4100502	Mounting Screw, 10-32 x 1/2" Tamperproof (Holt Head)
-	4107101	Flatwasher, #10
3	39194000	Barrier Strip, (2) Terminal
-	4080624	Mounting Screw, 8-32 x 5/8" Pan Head
-	4087000	Lockwasher, #8
-	4088001	Hexnut, 8-32
4	6198002	Muffin Fan (B2, B3), 115 V.AC, 50/60 Hz.
5	88253000	Power Cord with Molded Plug
6	4198054	Grommit, Black Rubber
7	7201024	Lamphouse Top Cover*
8	2140011	Molex Plug, (2) Pin
-	2162037	Molex Pin, Male
9	2140019	Molex Receptacle, (2) Pin
-	4162026	Molex Pin, Female

* Item 7 Top Cover not included with 7201036; see Figure 2, Item 26. Discard Cover Plate (Figure 2, Item 27) to permit mounting Exhaust Blower Assembly.

