

# INSTRUCTION MANUAL

## XENON SUPER TROUPER

### *Short Throw*

Follow Spotlight

Type 83061, 83081

Rev. September 2002



## **STRONG INTERNATIONAL**

a division of Ballantyne of Omaha, Inc.

4350 McKinley Street

Omaha, Nebraska 68112 USA

Tel 402/453-4444 • Fax 402/453-7238



## PREFACE

THE STRONG XENON SUPER TROUPER is a direct current follow spotlight system complete with a xenon lamphouse, power supply, optical system, base and yoke assembly, and six-color boomerang.

ONLY THE SPECIAL XENON POWER SUPPLIES manufactured by Strong International can be used with the xenon spotlight. For installation and operation of the power supply, see the manual furnished separately.

THE XENON LAMPHOUSE utilizes a deep ellipse dichroic metal reflector designed to operate in a fixed position with a horizontally mounted xenon bulb as the light source. A heat filter is located in the front of the lamphouse to reduce the heat at the optical system and color boomerang.

ONLY XENON BULBS designed for horizontal operation should be used in this spotlight. The presently approved ratings for bulbs used in this spotlight are 1000, 1600, and 2000 watt. See the listing in this manual for the approved types and necessary adapters.

ADJUSTMENT CONTROL for positioning the xenon bulb is located at the rear of the lamphouse. The adjustments are for the horizontal, vertical, and focus control of the bulb.

THE LAMPHOUSE INSTRUMENT PANEL is equipped with an ammeter and running time meter. The ammeter indicates the operating current of the lamp, and the running time meter records the number of hours the lamp has operated.

THE BULB is ignited and extinguished by use of the LAMP switch mounted on the instrument panel. Remote ignition switching is accommodated by wiring a five ampere dry contact across wires 3 & 6. See the Interconnection Wiring Diagram.

THE LAMP BLOWER, internally wired in the lamp, operates on 115 V.AC and is required to keep the seals on the bulb at a safe operating temperature. This blower will operate continuously until power is turned off at the main line switch to the xenon power supply. An air flow switch in the lamphouse prevents operation of the xenon lamp if the blower is not operating, or the airflow is inadequate.

THE LAMPHOUSE is supplied with a 13 foot cable containing the two DC leads, the ground lead, and all AC control leads. The cable terminates in a multiple-pin MS connector to mate to the receptacle on the power supply.

WHEN TRANSPORTING the follow spotlight, it is recommended that the xenon bulb be removed from the lamphouse and placed in its original shipping carton with the cover on the bulb to prevent breakage.

# LAMPHOUSE - POWER SUPPLY Interconnection Diagram

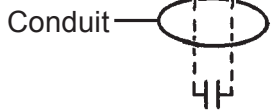
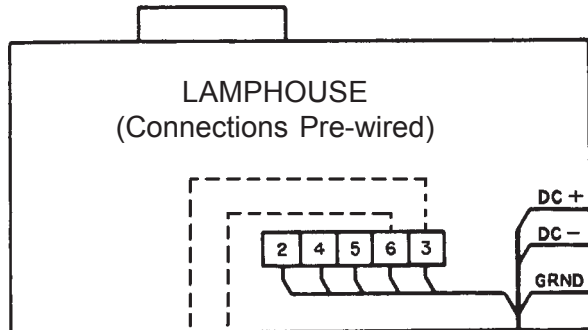

Remote - Auto Sustained 5 Amp. Dry Contact  
(by Installer as req'd.)

### MS CONNECTOR

Pin	Wire No.
A	DC-
B	DC+
C	2
D	3
E	4
F	5
G	6
I	7
J	8
M	Grnd

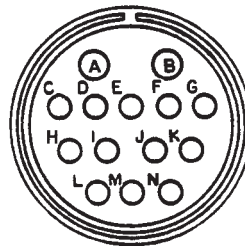

**SYSTEM MUST BE GROUNDED**  
All wiring must conform to local codes;  
shield lamphouse cable in conduit if required.

Check Slide Switch (below) on Power Supply for correct positioning.

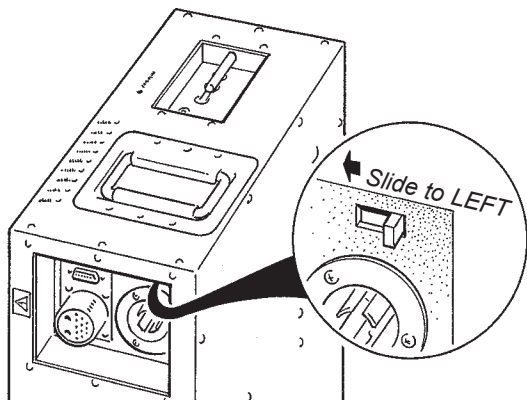
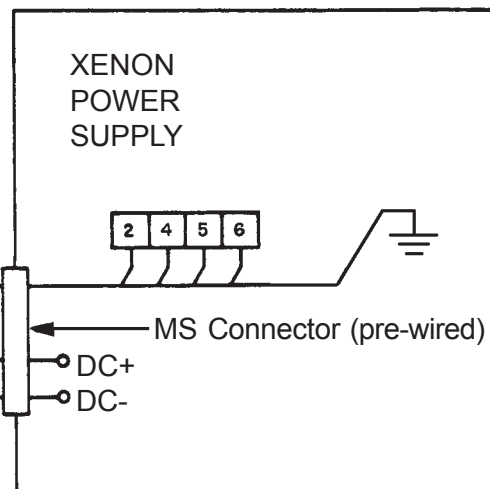

## INSTALLATION AND SETTING UP SPOTLIGHT

THE XENON SUPER TROUPER is shipped in sections which must be assembled. The Folding Base Stand Assembly 65838 is shipped collapsed, and requires only folding down and pinning the base legs.

WHEN INSTALLED in a permanent location, the (4) leveling feet must be removed, and the clearance holes in the base leg brackets used for hardware (user supplied) to bolt the base to the floor or platform. If it is desired to have the unit portable, when operating, the leveling feet *must* be adjusted down until the weight of the spotlight has been shifted from the casters to the leveling feet.

THE INNER TUBE and support yoke has three holes to permit adjusting the height of the spotlight. The three holes are on four-inch centers and will allow an optical height of approximately 53 inches, 57 inches, and 61 inches above floor level to the optical center of the lamphouse and lens system. Insert the height location pin through the hole in the outer tube and one of the holes in the inner tube. The leveling feet may be adjusted through an additional two-inch range.

THE HORIZONTAL SWING and vertical tilt locking knobs are on the right hand (operating) side of the yoke assembly. Tighten both of these locking devices securely before attempting to place the lamphouse and lens system on the support yoke.

PLACE THE LAMPHOUSE and lens system on the yoke assembly, with the spot size control handle to the right hand (operating) side, the same as the locking controls on the yoke. Line up the four mounting holes in the bottom of the base rail with the four mating holes in the support yoke and secure with the four 5/16-18 wing screws.

ATTACH THE COLOR BOOMERANG to the front of the optical system by inserting the hinge pin through the hinge on the boomerang and optical system. Fasten the boomerang yoke to the slotted angle bracket on the underside of the optical system pan. Adjust and securely tighten the wing nut and lock nuts to hold the boomerang parallel with the front of the optical system housing.

ATTACH THE LAMPHOUSE CABLE connector to the receptacle on the power supply. Align the pins before tightening the locking ring. Do not energize the xenon power supply before first installing the xenon bulb into the lamphouse.

CHECK THE SLIDE SWITCH on the 62-80106 xenon power supply cabinet and verify that it has been paced in the "LAMPHOUSE" position. See the illustration on the inside front cover of the Xenon Power Supply Instruction Manual.

## SAFETY PROCEDURES

THE XENON BULB is highly pressurized. When ignited, the normal operating temperature of the bulb increases the pressure to a level at which the bulb may explode if not handled in strict accordance to the manufacturer's operating instructions. The bulb is stable at room temperature, but may still explode if dropped or otherwise mishandled.

REFER bulb replacement and service to QUALIFIED PERSONNEL with adequate protective clothing (face shield, clean cotton gloves, welder's jacket). For routine lamphouse service, observe the following rules:

1. Allow the bulb to cool to room temperature before opening the lamphouse. Put on protective clothing described above.
2. De-energize the xenon power supply at the AC source before opening the lamphouse compartment.
3. When possible, encase the bulb in its protective cover when cleaning or servicing the lamphouse interior. The bulb, when outside the lamphouse, must be encased in the cover.
4. Clean the bulb after it has cooled to room temperature. Do not touch the quartz envelope of the bulb; fingerprints will burn in and create hot spots which may shorten bulb life. If fingermarks are made, they should be carefully removed with methyl alcohol and cotton prior to bulb operation.
5. Never view an ignited bulb directly. **BLINDNESS OR PERMANENT EYE DAMAGE MAY BE INCURRED.**
6. Use only xenon bulbs designated as OZONE FREE. When possible, vent the lamphouse exhaust to outside atmosphere.
7. Maintain the lamphouse blower in good operating condition. Keep the blower inlet clean for unrestricted air flow.
8. To insure maximum bulb life, operate the lamphouse blower and the exhaust system for *at least* ten minutes after extinguishing the bulb.
9. If returning a bulb for warranty adjustment, pack it in its original shipping container. Complete and return all required warranty information.
10. Dispose of expired bulbs that are beyond warranty in the following manner: Wrap the bulb tightly in several layers of canvas or heavy cloth. Place it on a hard surface and shatter the envelope with a sharp hammer blow. **DO NOT** place an unshattered bulb in an ordinary refuse container.
11. **DO NOT PERMIT UNAUTHORIZED PERSONNEL TO PERFORM OR ATTEMPT ANY PHASE OF XENON BULB HANDLING OR SERVICE.**

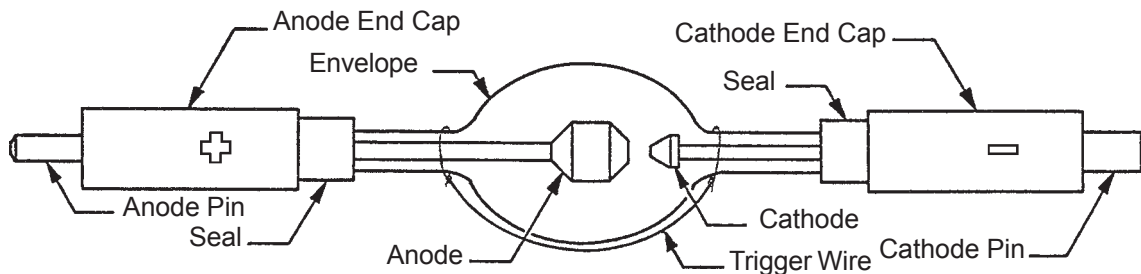

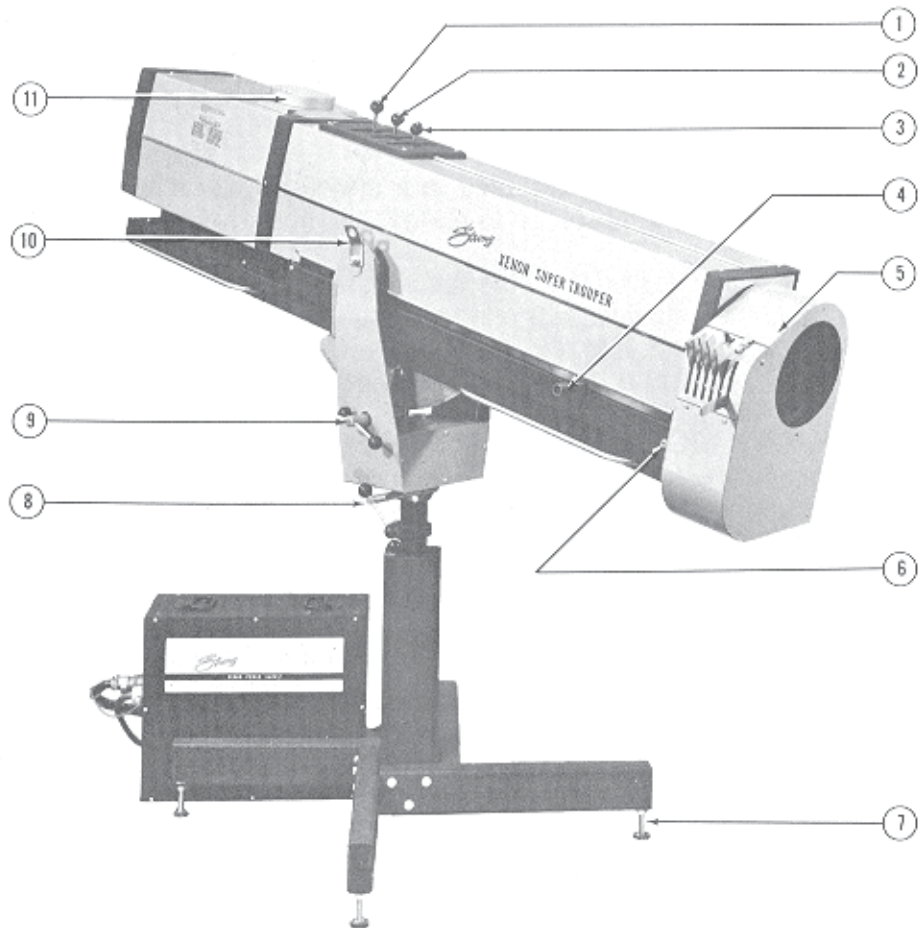

1. Fade-Out Mechanism Control Lever
2. Masking Shutter (Chopper) Control Lever
3. Iris Control Lever
4. Spot Size Control Handle
5. Color Boomerang
6. Spot Focus Knob
7. Leveling Foot
8. Horizontal Swing Control Lever
9. Vertical Tilt Control Lever
10. Lifting Strap
11. Cap, Exhaust Stack

## EXHAUST SYSTEM INSTALLATION

IF THE SPOTLIGHT is installed in a closed booth, it is recommended to vent the lamphouse exhaust to outside atmosphere to remove the heat from the booth.

THE EXHAUST STACK of the lamphouse is designed to fit a six-inch diameter duct. The exhaust system must be designed and installed in a way to eliminate any possibility of a down draft or of rain dripping into the lamphouse. The exhaust fan must be capable of removing 750 lineal feet (150 cfm) of air per minute at each lamphouse.

TO PERMIT MOVEMENT of the follow spotlight, install a section of six-inch diameter flexible non-flammable tubing between the lamphouse exhaust stack and the projection booth exhaust system. The two holes in the stack exposed by removing the vent cap can be used to secure the tubing.

IF THE INSTALLATION is to be made in a location where it is not possible to install an exhaust system, leave the vent cap mounted to the exhaust stack.

THE RADIATION from some xenon bulbs can convert the oxygen in the surrounding air to ozone. In large quantities, ozone can endanger health, but it spontaneously changes back into oxygen in a very short time, especially if it mixes with a large volume of air (as in an auditorium, arena, or outdoors). Most currently manufactured xenon theater bulbs are classified as *ozone free* and do not release ozone.



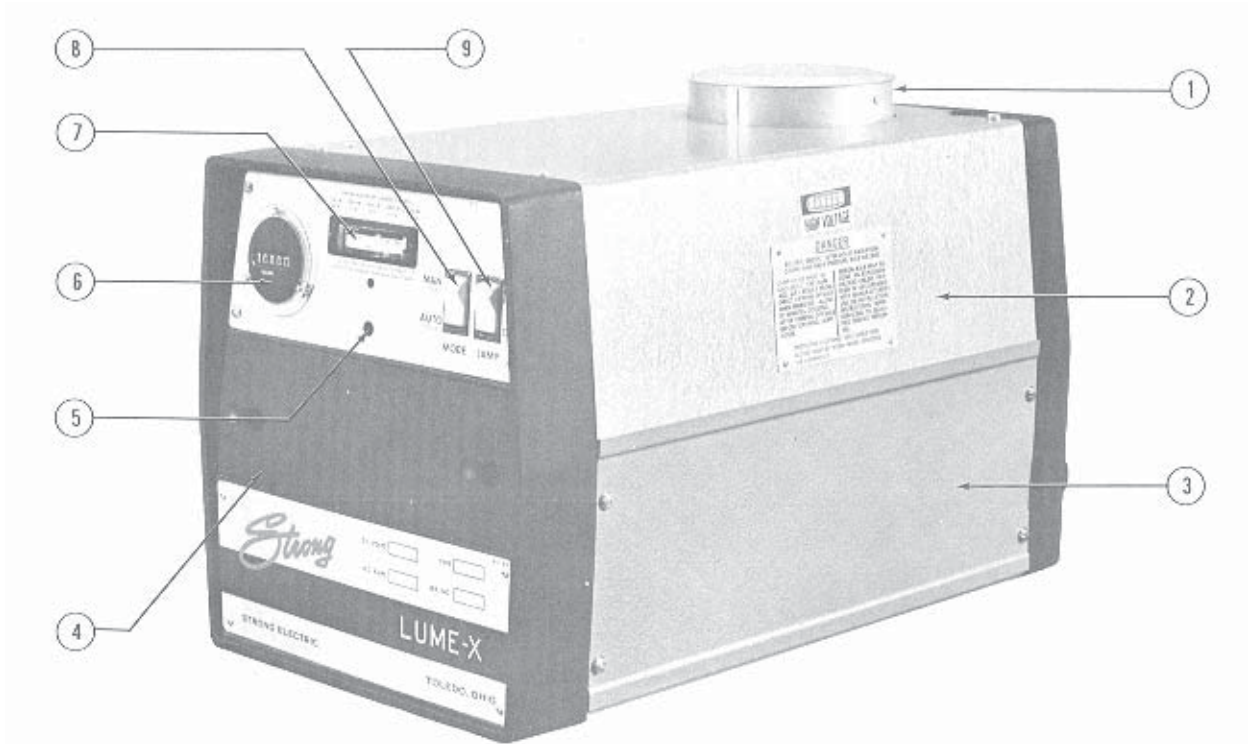

1. Cap, Exhaust Stack
2. Top Cover, Lamphouse
3. Access Panel, Igniter
4. Cover, Bulb Adjust
5. Current Control (early models)
6. Elapsed Time Meter
7. Ammeter
8. MODE Switch (AUTO-MAN.)
9. LAMP Switch (ON-OFF)

# BULB ADAPTERS, 1000 & 1600 WATT BULBS

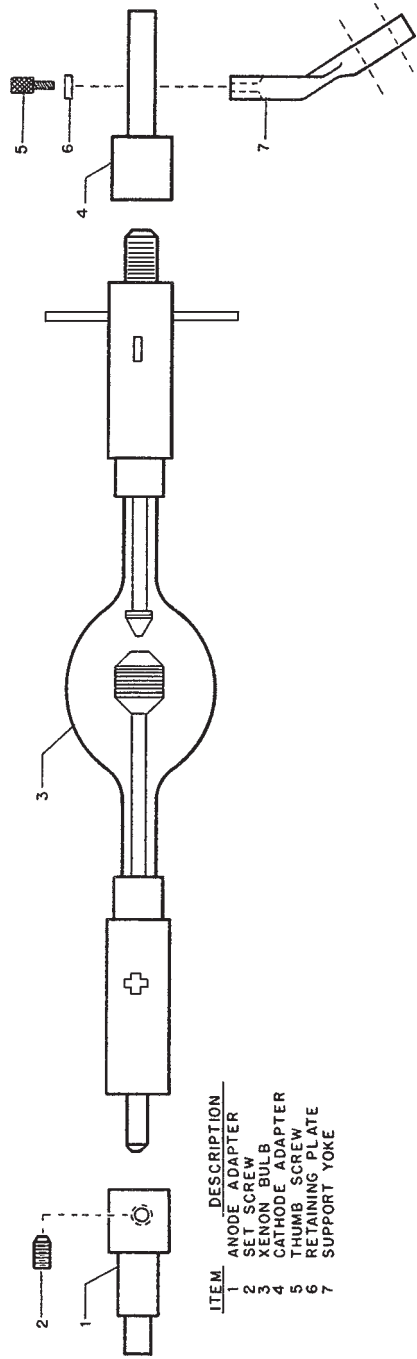

Item No.	OSRAM 1 kW	OSRAM 1.6 kW	Hanovia 1 kW	Hanovia 1.6 kW
1	65199	65199	65259	65403
2	4100180	4100180	4100180	4100180
3	XBO1000W/HS LTIX1000W-HS	XBO1600W/HS LTIX1600W-HS	XH1000HS 65198	XH1600HS 65198
4	65198	65198		

*LTIX Bulbs (Lighting Technologies Inc.) bulbs are interchangeable with OSRAM.*  
**TYPE "HSC" BULBS (without Anode Pins) CANNOT BE USED IN THE XENON SUPER TROUPER**

## BULB INSTALLATION

CAUTION: OBSERVE ALL SAFETY PROCEDURES. Put on the protective face mask. Wear clean cotton gloves to prevent marking the quartz envelope of the bulb with fingerprints.

REMOVE THE TOP COVER of the lamphouse by removing the four Holt head (tamperproof) screws with the special screwdriver provided.

NO BULB ADAPTERS are required to install the 2000 watt bulb in the 83080 Xenon Super Trouper lamphouse. Adapters used to install the 1000 watt or 1600 watt bulb in the 83060 lamphouse are supplied in the accessory kit. See the Bulb Adapter Chart for the correct adapters and sequence of assembly. Handle the bulb by its metal end caps only.

ASSEMBLE THE REQUIRED ADAPTERS to the 1000 or 1600 watt bulb prior to inserting the bulb into the lamphouse. Be very careful **not** to apply any strain on the quartz envelope when installing adapters. Screw the threaded cathode adapter on the negative stud so it seats firmly against the shoulder of the cathode (-) end cap. Apply torque using the pins on the cathode end cap. Slip the anode adapter with set screw over the positive stud, up to the shoulder of the anode (+) end cap. Tighten all fasteners securely to insure a good electrical connection.

REMOVE THE PLASTIC PROTECTIVE COVER from the xenon bulb only if necessary. Insert the bulb through the top of the lamphouse, between the reflector support and the front casting. Pass the anode (+) end of the bulb through the hole in the reflector, taking care **not** to touch the surface of the reflector.

INSERT THE ANODE ADAPTER STEM of 1000 and 1600 watt bulbs into the rear support collet. The stem must be inserted as far as possible to permit full focus travel of the bulb. Place the cathode adapter into front bulb support, pivot the retaining plate to its closed position, and tighten the (2) thumb screws. Tighten the socket head clamping screw in the anode contact securely to insure a good electrical contact.

INSTALL THE CATHODE LEAD CONTACT over the end of the cathode adapter up to the shoulder of the contact and tighten the clamping screw securely. Lay the lead in front of the air duct to minimize the shadow.

THE 2000 WATT bulb mounting components include a shock mount support at the front of the lamphouse. Insert the 2000 watt bulb through the top of the lamphouse, passing the anode (+) end through the hole in the reflector. Pass the anode pin as far as possible to the rear of the lamphouse to permit sliding the cathode (-) end cap through the ring of the shock mount. Insert the anode pin into the bulb support collet and firmly tighten the socket head clamping screw. Slide the cathode contact clamp over the cathode pin and tighten securely.

AN ALTERNATE METHOD of installing the 2000 watt bulb is to dismount the shock mount ring from the front bulb support assembly by removing the socket head screw. Slide the ring over the cathode (-) end cap of the bulb, and install the bulb by inserting the anode (+) end cap through the reflector center hole and seating the anode pin into the rear support collet. Re-mount the ring to the base of the front bulb support using the socket head screw. Secure the anode (+) clamping screw; install and tighten the cathode (-) contact clamp.

THE SOCKET HEAD SCREW which mounts the bulb support ring to its support bracket must be tightened securely enough to *clamp* the upright bulb support ring in a vertical (90°) position and prevent its tilting forward or back as the bulb is focused. The end cap of the bulb should touch only the coils of the shock mount spring to allow the bulb to slide forward and back with a minimum of friction and *no stress* on the quartz envelope.

OBSERVE THE POSITION of the Trigger Wire on the xenon bulb relative to the point where the bulb passes through the center hole of the reflector. Some bulb manufacturers attach one end of the trigger wire to the anode end cap; if this trigger wire approaches the reflector too closely, the DC current will follow this path to ground and prevent bulb ignition. To avoid this, detach the trigger wire from the anode end cap and loop it around the bulbous portion of the envelope as illustrated on the line drawing at the end of the SAFETY PROCEDURES page.

IT IS RECOMMENDED to establish a routine for periodically checking all electrical connections for tightness, particularly those at the bulb. A loose connection in the DC circuit will cause failure of the contacts and leads, and may destroy the bulb.

THE REFLECTOR is optically positioned at the factory. Do not alter the position of the reflector by adjusting the tie rod located in the upper corner of the lamphouse.

## 1000, 1600 WATT BULB INSTALLATION

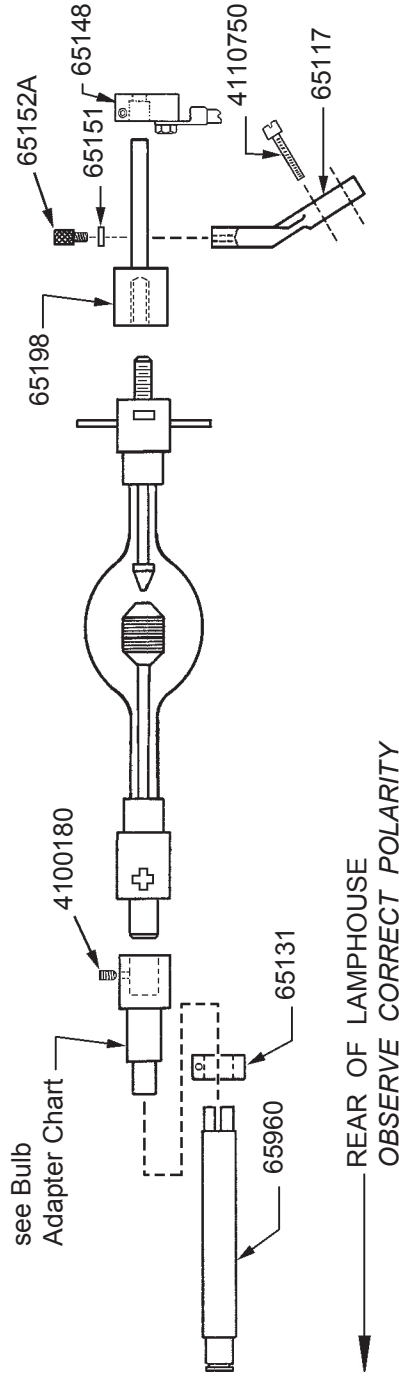

**DETACH & DISCARD ANY FACTORY-MOUNTED  
LEAD CONNECTED TO BULB END CAP**

Part No.	Description
65117	Bulb Support Yoke
65131	Anode (+) Contact Clamp
65148	Cathode (-) Contact Clamp
65960	Rear Bulb Support Collet, 2 kW
4080870	Clamping Screw (for 65131 & 65148)
4100180	Set Screw, Anode Adapter
4110750	Bulb Support Mounting Screw
4250373	Lead Mounting Screw (for 65131 & 65148)
<i>NOT SHOWN</i>	
65948	Negative (-) Lead Assembly
65966	Positive (+) Lead Assembly

1000 Watt Operation: 50 Amperes Nominal  
**DO NOT EXCEED 58 AMPERES**

1600 Watt Operation: 65 Amperes Nominal  
**DO NOT EXCEED 70 AMPERES**

## 2000 WATT BULB INSTALLATION

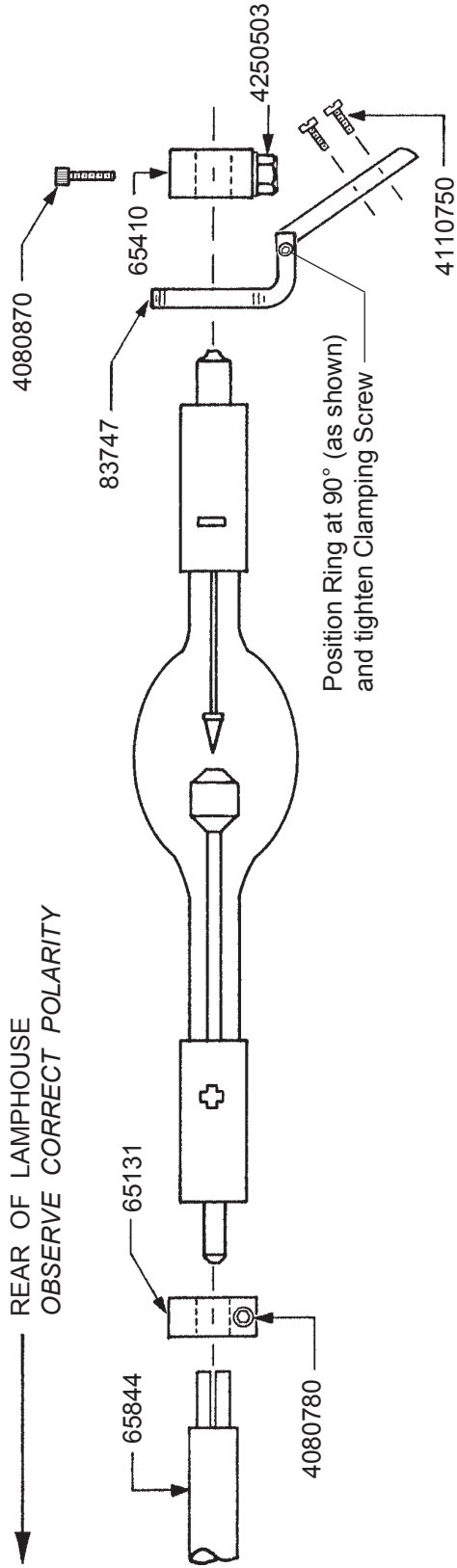

**DETACH & DISCARD ANY FACTORY-MOUNTED LEAD CONNECTED TO BULB END CAP**

**SHORT 2000 WATT (Type "HS") BULB NOT USED IN XENON SUPER TROUPEL**

**2000 Watt Operation: 75 Amperes Nominal  
DO NOT EXCEED 90 AMPERES**

Part No.	Description
65131	Anode (+) Contact Clamp
65410	Cathode (-) Contact Clamp
65844	Rear Bulb Support Collet, 2 kW
83747	Front Bulb Support Assembly
408070	Clamping Screw
4110750	Bulb Support Mounting Screw
4250503	Lead Mounting Screw
<i>NOT SHOWN</i>	
65948	Negative (-) Lead Assembly
65966	Positive (+) Lead Assembly

## OPERATION

REMOVE THE PLASTIC COVER from the xenon bulb. **Do not** ignite the lamp with the cover on the bulb.

A GLASS HEAT FILTER is supplied to reduce the temperature at the optical system and color gels. Insert the heat filter in the bracket provided on the inside of the lamphouse at the front opening. Place the filter in position *with the coated surface facing the bulb*. The coated surface is indicated by a small *XX* or other marking. This filter is a narrow strip that covers only the center portion of the beam. To prevent damage to optical system components, **do not** operate the spotlight with the filter removed or reversed.

SECURE THE LAMPHOUSE COVER with the (4) tamperproof screws using the special screwdriver provided. The cover must be securely in position to actuate the interlock switch and permit lamp ignition.

PLACE THE MODE SWITCH (on units so equipped) in the “MAN.” position and energize the xenon power supply. The lamphouse blower will start and actuate the blower interlock switch to permit bulb ignition. This lamp blower will operate continuously until the xenon power supply is de-energized.

PLACE THE LAMP SWITCH in the ON position and the xenon bulb will ignite. Allow a few minutes for the current to stabilize, and read the lamphouse ammeter. The bulb must be operated within the current range specified by the bulb manufacturer. The ranges for the xenon bulb supplied with the unit are as follow:

<u>WATTAGE</u>	<u>NOMINAL CURRENT</u>	<u>DO NOT EXCEED</u>
1000	50 A.	58 A.
1600	65 A.	70 A.
2000	75 A.	90 A.

ADJUST THE POWER SUPPLY as instructed in the power supply manual for the correct operating current. The current setting must be increased in time to compensate for bulb aging, but *do not*, at any time, exceed the maximum current rating.

REMOVE THE REAR COVER PANEL (two pull-type knobs) to expose the bulb position adjustment control.

THE CENTER SECTION of the control is a threaded member that focuses the bulb in relation to the reflector. Turning this adjustment moves the bulb on the horizontal plane, into or out of the reflector. Rotating this section clockwise moves the bulb away from the reflector. The small knurled screw to the left of this section can be tightened to lock the focusing mechanism in place after the bulb alignment procedure has been completed.

THE THUMB SCREWS to the left and right of the focusing control lock the horizontal and vertical position of the bulb.

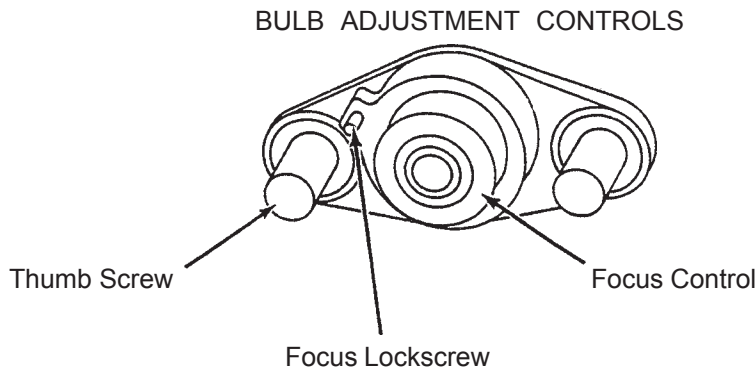

TWO METHODS are recommended to align the bulb in order to project the best light to the stage.

MOVE THE SPOT SIZE CONTROL HANDLE on the large lens carriage to the forwardmost position to project the smallest spot possible with the iris, choppers, and dimming control in the full open position. Project the spot to a wall or similar flat perpendicular surface opposite the spotlight.

TURN THE CENTER FOCUS CONTROL counterclockwise until a small black spot is projected on the wall. It may be well to run this adjustment both directions to permit positive identification of the dark spot.

LOOSEN THE TWO THUMB SCREWS to the left and right of the focus control just enough to permit manual movement of complete control assembly. Move the control assembly around the two thumb screws and observe the smooth dark shadow of the bulb electrode inside the shaded circle of the reflector center opening. The shadow of the electrode must be centered in the projected opening of the reflector.

MOVE THE CONTROL ASSEMBLY around the thumb screws until the dark electrode shadow is as round as possible to project. It may be necessary to again rotate the focus control to define the electrode shadow.

AFTER THE ELECTRODE SHADOW is as even around the outside as possible, tighten the two thumb screws to lock this adjustment in place, and rotate the focus control to obtain the brightest light with the best light distribution. Turn the spot focus control knob, located on the front of the lens mechanism, to sharpen the edge of the spot.

THE SECOND METHOD of aligning the xenon bulb is to project the spot to the stage, and using the bulb adjustment controls, obtain a "hot spot" in the projected spot. Center this "hot spot" in the projected spot by moving the entire control section around the two thumb screws.



Once the “hot spot” is centered in the projected spot, lock the adjustment control in position with the two thumb screws and rotate the focus control to obtain a spot with an even distribution of light. Turn the spot focus control knob at the front of the lens mechanism to sharpen the edge of the spot.

THIS ADJUSTMENT should not be disturbed until the xenon bulb is replaced. At this time it will be necessary to repeat the alignment procedure.

REPLACE THE REAR COVER PANEL over the bulb adjustment control mechanism. Secure using the plastic fasteners.

BECAUSE OF MANUFACTURING TOLERANCES and normal bulb aging, it may be necessary to operate one lamp at slightly higher or lower current than others to obtain equal light balance between units. These adjustments are made at the xenon power supply.

TO EXTINGUISH THE ARC, place the LAMP switch in the OFF position. The blower in the lamphouse will continue running until the xenon power supply is de-energized. Allow the blower to operate and cool the bulb for *at least* five minutes after extinguishing. This measure will prolong bulb life.

TO OPERATE THE SPOTLIGHT from a remote location or an automation controller, the lamphouse must be equipped with the MODE (Auto-Man.) switch. With the MODE switch in the “AUTO” position, and the LAMP switch “ON,” the lamphouse will ignite by means of a dry contact across terminals 3 and 6 at the lamphouse or power supply (See Lamphouse-Power Supply Interconnection Diagram). This type of installation is intended for use *only* if the spotlight is “locked down” as a fixed spot without an operator at the unit.

## HANDLING THE SPOTLIGHT

GENERALLY THE BEST POSITION for the operator to stand is near the center of the spotlight, on the right hand side, although the angle of tilt and the size of the porthole may alter the position for the most convenient operation.

EACH OPERATOR will, after a few minutes of operation, generally develop his own system and position for operating the unit.

THE HORIZONTAL SWING LOCK LEVER and vertical tilt lock lever located on the base assembly can be set to give the desired amount of friction on the spotlight swing to suit the individual operator.

THE LENS CARRIAGE FRICTION BRAKE is a nylon drag screw located on the outrider of the large lens carriage (see Figure 6, Item 14), and is preset at the factory for normal operation. Individual requirements may vary, and the brake can be adjusted to best suit the operator or allow for a severe “down” angle. Remove the color boomerang and lens mechanism housing, loosen the nylon lock nut and adjust the screw on the friction brake to apply the desired tension. Tighten the lock nut and replace the housing and boomerang.

## OPERATION OF OPTICAL SYSTEM

THE IRIS CONTROL is the front lever which projects through the top of the optical system housing. When this lever is to the left (as viewed from the rear of the unit), the largest aperture is provided. Smaller apertures are obtained as the lever is moved to the right.

THE SPOT SIZE CONTROL HANDLE is located on the right hand side of the optical system just above the base rail. A variation of spot sizes from full flood to small spot can be obtained by moving the spot size control handle from one extreme to the other. Beam intensity is increased by this optical system when reducing from flood to spot, and maximum intensity is reached when the spot size control handle is in the extreme forward position.

THE MAXIMUM FLOOD SPOT is obtained with the iris control lever to the left (away from operating side) for the largest aperture and with the spot size control handle moved as far to the rear as possible.

SMALLER SIZED SPOTS are projected as the spot size control handle is moved forward. Most of the spot sizes needed will be produced with the iris in its maximum open position.

FOR A "HEAD SPOT," or any spot smaller than can be obtained with the spot size control handle in its extreme forward position, shift the iris control lever to the right (toward operating side) for a smaller aperture. The iris control lever should always be returned to its extreme left position before the spot size control handle is again moved to obtain larger spots.

THE MASKING SHUTTER (chopper) lever is the middle lever projecting through the top of the optical system housing. The masking shutter blades are operated by this lever to shape the projected spot to a rectangle, strip spot, or dousing.

THE DISENGAGED POSITION of the masking shutter lever is to the extreme right (toward operating side) and varying degrees of masking to complete cutoff are obtained by moving the lever to the left (away from operating side).

THE ANGLE of the masking shutter blades can be adjusted to compensate for the horizontal projection angle. Remove the color boomerang and optical system housing, and loosen the screws holding each of the masking shutter blades enough to allow movement. Ignite the bulb and adjust the angle of the *bottom* blade by tapping with a screwdriver so its projected edge lies parallel to the footlights. Tighten the screw. Operate the masking shutter lever to close the blades. Adjust the upper blade to close in line with the bottom blade and tighten the screw.

THE FADEOUT MECHANISM AND DOUSER CONTROL is the rear lever projecting through the top of the optical system cover. This lever controls the intensity of light from complete fadeout when the lever is to the left, to full intensity when the lever is to the right.

THE SPOT FOCUSING CONTROL KNOB is located on the operating side of the optical system at the forward end above the base rail. This control is used to position the lenses of the optical system for the length of throw. When making an adjustment, rotate the spot focusing control knob until the sharpest edge is obtained on the projected spot.

## OPERATION OF COLOR BOOMERANG

THE COLOR BOOMERANG is equipped with six color filters and provision has been made for installation of an optional ultraviolet filter. The ultraviolet filter may be purchased as an accessory (Order No. 51829) and is easily mounted to the front of the boomerang. Additional filter holders (51928 & 51376) can be supplied by your Strong International Dealer.

TO OPERATE INDIVIDUAL COLOR FILTERS, lower the desired filter selector lever. A rocker catch located in the color disc housing holds the filter in position.

TO RELEASE A COLOR, push the filter release arm up or engage another color, thus releasing the previous color automatically.

TO REPLACE A FILTER HOLDER, open the hinged top of the color disc housing and lift out the desired filter holder.

NOTE: WHEN PLACING COLOR FILTERS into the boomerang, the *less* dense colors (pink, amber) should be placed in the holders toward the **rear** of the boomerang (toward arc), and those of *greater* density (red, green) should be placed in the holders toward the **front** of the boomerang (away from the arc).

COLOR TEMPERATURE REDUCTION FILTERS, required for use with television and videotape, are available from theatrical supply dealers.

## MAINTENANCE

THE XENON SUPER TROUPER SPOTLIGHT requires very little maintenance to keep it in good working order.

THE REFLECTOR should be cleaned periodically with a clean, soft, lint-free cloth to remove any dust from the reflective surface. *Do not* use abrasive cleaners.

CHECK ALL ELECTRICAL CONNECTIONS periodically for tightness, especially the bulb connections and other leads in the DC circuit.

THE XENON LAMPHOUSE requires no lubrication other than the blower motor. This should be lubricated with two or three drops of non-detergent oil at each oil hole every six months. The lamphouse cover must be removed to expose the oil holes.

THE XENON BULB should be checked occasionally for presence of foreign material on the envelope. Any dirt or other foreign material must be removed immediately. **CAUTION:** Observe all safety procedures when working around the exposed bulb.

THE INSIDE OF THE LAMPHOUSE and the blower should be cleaned periodically, depending on the dust conditions at each installation. The blower requires cleaning to remove dust build up which accumulates over a period of time. Keep the air inlet grille clean to permit free air flow.

THE OPTICAL SYSTEM LENSES must be kept clean to prevent any light reduction in the projected spot. To gain access to the lenses, tighten the horizontal swing and vertical tilt locking clamps, and remove the color boomerang and optical system housing.

CLEAN THE PROJECTION LENS and large lens with any cleaner approved for use on coated projection lenses. If the projection lens is removed for cleaning, the end of the lens tube with the FL marking ring must be toward the iris when replaced in its support.

WHEN TRANSPORTING the spotlight, it is recommended that the xenon bulb be removed and placed in its original shipping carton with the cover on to insure against breakage. If the spotlight is equipped with a bulb shock mount, the unit may be transported with the bulb installed, assuming reasonable caution is exercised. Under *no* circumstances should the unit be moved until the bulb has cooled to room temperature.

# LAMPHOUSE SCHEMATIC

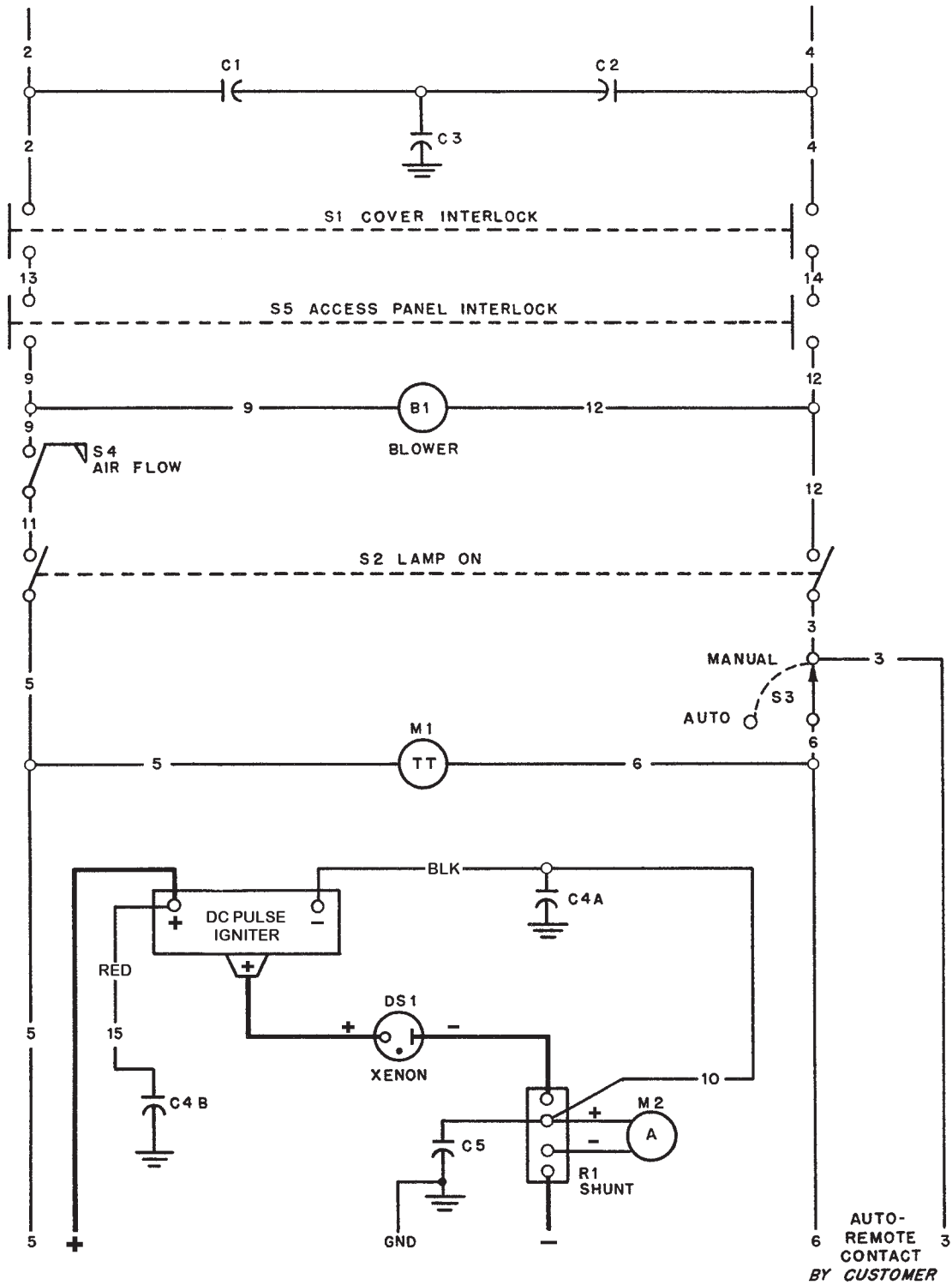

**SCHEMATIC DIAGRAM**  
Parts List

Ref.		
<u>Desig.</u>	<u>Part No.</u>	<u>Description</u>
-	65503	DC Pulse Igniter Assembly
-	65858	Igniter Case & Coil Assembly
-	25476	Igniter Printed Circuit Board Assembly
B1	65932	Blower, 115 V.AC, 50/60 Hz.
C1,2	76132	Capacitor, .005 $\mu$ f, 600 WVDC
C3	76133	Capacitor, .01 $\mu$ f, 400 WVDC
C4A,B	80177	Capacitor, 1.0-1.0 $\mu$ f, 600 WVDC
C5	81947	Capacitor, .01 $\mu$ f, 500 WVDC
DS1	-	Xenon Bulb
M1	65891	Elapsed Time Meter (60 Hz.)
-	65870	Elapsed Time Meter (50 Hz.)
M2	65142	Ammeter, 0-150 A.
R1	82167	Shunt, 150 A. 50 mV.
S1	80168	Cover Interlock Switch
S2	81275	LAMP Switch, "ON-OFF"
S3	81276	MODE Switch, "AUTO-MAN."
S4	85109	Air Flow Switch
S5	80168	Access Panel Interlock Switch
-	65935	Lamphouse/Power Supply Interconnect Cable (with MS Connector)

\* 88122 used with Type 88000 Power Supplies only

Specify Equipment Type and Serial Number when ordering replacement parts.

## TROUBLE CHART

### NORMAL OPERATION

WHEN THE SWITCH in the main AC supply line to the xenon power supply is in the ON position, and the 30 A. circuit breaker on the switching power supply is ON, the green 20 VDC, VIN, and FUSE lights on the xenon power supply will glow. The lamphouse blower will start.

OPERATION OF THE LAMPHOUSE BLOWER will close the air flow interlock switch, and assuming the lamphouse top cover and side access panel are correctly installed, the control circuit to the LAMP switch will be completed.

THE MODE SWITCH, located on the lamphouse instrument panel, should be in the "MAN." (manual) position. This is the normal setting for spotlight operation, as it allows direct ignition control by the operator.

WHEN THE "LAMP" SWITCH is placed in the ON position, the AC control circuit in the lamphouse will energize the power supply circuitry providing DC current to the igniter and bulb. The green GO power supply indicator light will glow, and high "no load" (open circuit) DC voltage will be applied to the DC pulse igniter.

THERE WILL BE a distinctly audible high voltage arc ping at the igniter arc gap and across the bulb electrodes. The bulb should ignite immediately after one or two of these high voltage pulses, and the lamp current will adjust to the output setting of the xenon power supply. Multiple ignition pulses prior to bulb ignition normally indicate a low DC output setting. See xenon power supply manual. A "warm" or aged xenon bulb might also require multiple strikes.

### TROUBLE SHOOTING

IF THE XENON BULB does not ignite, observe the following operational sequences for assistance in locating and isolating the trouble area.

WHEN THE FANS and the green indicator lights on the power supply are on, the AC circuit in the power supply is trouble free up to the terminal block in the power supply.

AT THIS TIME, the lamphouse blower should operate. If this does not occur, the trouble is in the cover interlock switch, the access panel interlock switch, the blower motor, a loose connection, or a broken #2 or #4 lead. **CAUTION:** To prevent bulb ignition when checking the AC control circuit in the lamphouse, temporarily remove DC lead #10 (black) or #15 (red) from the capacitor terminal. Check at this time for **115 V.AC Control Voltage** at the cover interlock switch (wires 2 & 4), the side access panel (wires 13 & 14), and the blower terminals (9 & 12). The cover interlock switch must be manually actuated to energize the blower. Replace DC lead before proceeding.



## TROUBLE SHOOTING (continued)

THE VANE on the air flow switch should raise. With the MODE switch in the “MAN.” position and the LAMP switch in the “ON” position, the running time meter should start and indicate elapsed time. If this meter does not operate, check for continuity at the MODE and LAMP switches.

A DEFECTIVE RUNNING TIME METER will *not* prevent bulb ignition.

WITH THE “LAMP” SWITCH in the “ON” position, a distinct high voltage arc ping should be heard at the spark gap in the igniter, and the flash of the xenon bulb should be visible through the ammeter as a high DC voltage pulse is applied across the bulb electrodes.

IF THE HIGH VOLTAGE PING or the flash at the ammeter is not apparent, check the “**No Load**” DC Voltage between the lamphouse and power supply. Measure the DC voltage across terminals #10 (-) and #15 (+). A reading of 130-170 V.DC should be measured. If this voltage is not indicated, the problem is in the leads between the lamphouse and power supply, or in the power supply boost circuit. See the trouble shooting section of the power supply manual for additional instructions.

IF THE HIGH VOLTAGE ARC is audible at the lamphouse and the bulb does *not* flash, check for a lamphouse DC lead arcing to ground. If no ground fault is detected, replace the bulb and attempt ignition with the new bulb.

IF THE HIGH VOLTAGE ARC is audible at the lamphouse, the flash of the bulb is visible in the ammeter, but ignition of the bulb is not sustained, the problem area is in the power supply. See the trouble shooting section of the power supply manual for additional instructions.

IF THE HIGH VOLTAGE ARC is *not* audible or the flash of the bulb visible, and DC “no load” voltage exceeds 130 V.DC, the problem is in the igniter assembly.

EXCHANGE of components (i.e. igniters, igniter PC boards) between similar Strong Xenon Super Troupers to aid in diagnosis of a problem is encouraged. This will not lead to equipment damage, and will not void equipment warranty.



### CAUTION - HIGH VOLTAGE



THE STRONG DC PULSE IGNITER STORES ENERGY IN ITS CAPACITORS AFTER THE UNIT HAS BEEN DE-ENERGIZED. TO PREVENT SHOCK, THIS ENERGY CAN BE DISCHARGED BY PLACING THE BLADE OF AN INSULATED-HANDLE SCREWDRIVER ACROSS THE METAL END CAPS OF THE SPARK GAP MOUNTED TO THE IGNITER PC BOARD.

## XENON SUPER TROUPER TROUBLESHOOTING

### **Bulb fails to ignite.**

1. MODE switch S3 set to "AUTO." Place in "MAN." position when not employing automated or remote lamphouse operation.
2. AC power not on to lamphouse. Turn switching power supply 30 A. circuit breaker ON. If 115 V.AC not read at 2 & 4, see power supply manual.
3. Top cover or side access panel interlock switch (S1, S5) open. Close and secure lamphouse top cover. Tighten all four mounting screws; check switch actuating screw. Tighten side access panel mounting screws.
4. Faulty interlock switch(s). Check for 115 V.AC at 9 & 12; replace switch(s) if defective.
5. Air vane switch S4 not closing. Check for unobstructed operation; clean if required. Check continuity between "NO" and "COM;" replace if defective.
6. Faulty S2 "ON-OFF" switch. Check for voltage at 3 & 5; check for loose terminals or wiring. Replace if defective.

### **Bulb fails to ignite; ping audible, bulb flash visible.**

1. Inadequate DC output from xenon power supply. Set power supply output to correct range required for bulb wattage (65 A. for 1.6 kW, 75 A. for 2 kW).
2. Faulty or expired xenon bulb. Replace as required.

### **Bulb fails to ignite; ping audible, no bulb flash.**

1. Faulty xenon bulb. Check for cracked electrodes or darkened envelope. Replace if defective.
2. Ignition pulse shorting to ground. Inspect DC leads for burned insulation; dress leads away from grounded metal components.

### **No high voltage ping audible; MODE switch in "MAN." and LAMP switch in "ON."**

1. Loss of AC control voltage. Check xenon power supply for tripped circuit breaker or open thermal switch. See power supply manual.
2. Little or no DC "No Load" voltage. Measure DC "No Load" voltage at 10 & 15. See power supply manual.
3. Open fuse (15 A.) in power supply primary module. SEE POWER SUPPLY MANUAL. Allow (10) minutes for capacitor discharge before replacing.
4. Loose or defective spark gap. Repair or replace igniter PC board as required.
5. Faulty igniter. Check for adequate DC "No Load" (130-180 V.DC) at 10 & 15. If present, and igniter does not fire, replace igniter.

### **Bulb goes out during operation.**

1. Xenon power supply overheated; thermal switch open. Check power supply blower(s), air inlets and outlets unobstructed. See power supply manual.
2. Xenon bulb depressurizing. Check for envelope discoloration; replace if defective.
3. Lamphouse blower B1 not moving adequate air. Clean and lubricate blower.
4. Lamphouse blower B1 failed or obstructed. Clean dust and dirt from blower inlet grille. Check for 115 V.AC at 9 & 12; replace blower if defective.
5. Lamphouse air vane switch S4 faulty. Check for vane actuation; adjust or replace as required.
6. Power supply brown-out protection actuated by voltage drop. See power supply manual.
7. Phase loss detected by power supply (3 phase units only). See power supply manual.

### **Power supply does not energize when actuated.**

1. S1 or S5 cover interlock switch, B1 blower, S4 air vane switch, S2 power switch, S3 MODE switch. Check for 115 V.AC at each station; replace defective component.

SEE POWER SUPPLY TROUBLESHOOTING UNDER SAME HEADING.

### **Noise in theatre sound as bulb ignites.**

1. Faulty RF suppression capacitor(s). Remove and test C1, C2, C3, C4A or C4B. Replace if defective.
2. Lamphouse, power supply, or sound system not properly grounded. Connect to adequate earth ground.
3. Leads between lamphouse and automation contact not shielded. Shield leads in conduit.

### **Excessive light flicker.**

1. Faulty or aged bulb. Check for cracked or sagging electrodes; replace if defective.
2. Excessive ripple in DC output. See power supply manual.
3. Arc stabilization magnet reversed. NORTH pole should point toward operator side. Check with compass if required.

### **Reduced light output.**

1. Normal bulb aging. Increase output current. DO NOT EXCEED MAXIMUM CURRENT SPECIFIED BY BULB MANUFACTURER.
2. Soiled reflector. Clean using commercial glass cleaner. USE NO ABRASIVES.
3. Soiled heat filter, projection lens or large lens. Clean as required.

### **Extremely long duration between ignition pulses.**

1. Low DC "No Load" from xenon power supply. Check "No Load" voltage; see power supply manual.

**Extremely long duration between ignition pulses (continued).**

2. Defective spark gap. A “Ping” sound is normal; excessive “Hissing” is abnormal. Replace if defective.
3. Low AC voltage to lamphouse. Check for 115 V.AC at 2 & 4; if below 95 volts, check stepdown or isolation transformer in xenon power supply. See power supply manual.

**Color gels burning or fading prematurely.**

1. Bulb focused to “hot spot.” Refocus bulb to flat field with iris fully open and spot size control handle (“trombone”) fully forward.
2. Heat filter glass reversed or peeled. Check for coated surface *toward* bulb; replace if coating peeled.
3. Reflector coating peeled. Replace if defective.

FIGURE 1

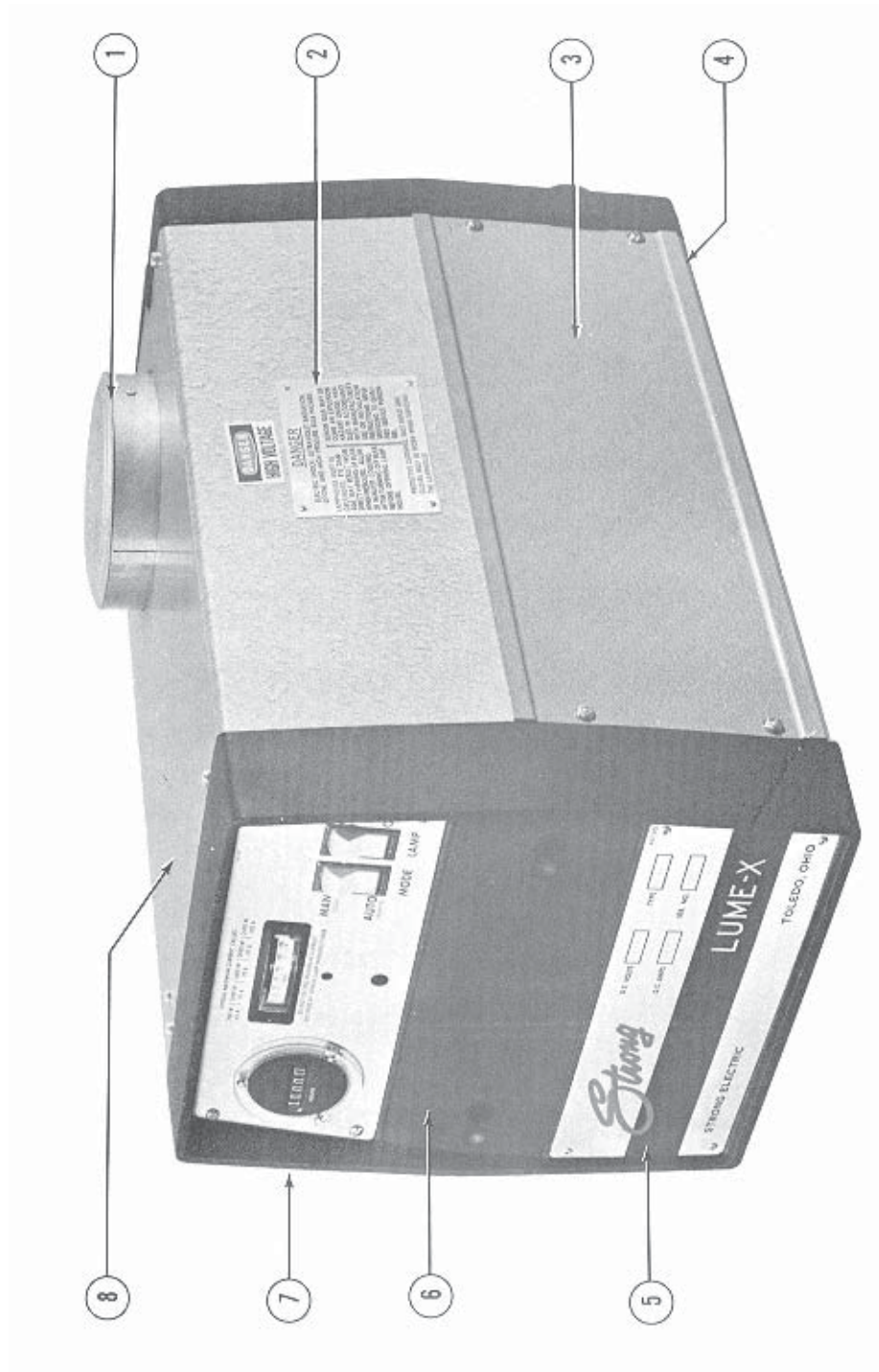

## PARTS LIST

Figure 1

<u>Item</u>	<u>Part No.</u>	<u>Description</u>
1	65866	Cap, Exhaust Stack
-	4060379	Screw, #6 Self-Tapping
2	81282	CAUTION Plate
-	01639-2	Pop Rivet, Aluminum
3	65864	Igniter Access Panel
-	4100502	Screw, 10-32 x 1/2" Holt Head (Tamperproof)
-	4107101	Flatwasher, #10
4	65865	Lamphouse Base Pan
-	65969	Base Adapter, Black Enamel (not shown)
-	4250503	Screw, 1/4-20 x 1/2" Hex Head
-	4257102	Flatwasher, 1/4"
-	4257001	Lockwasher, 1/4"
5	65100	Name & Data Plate
-	01639-2	Pop Rivet, Aluminum
6	65968	Cover Assembly, Bulb Adjust Controls
-	65140	Cover Plate
-	65166	Plunger, Black Plastic
-	65167	Grommet, Black Plastic
7	65880	Control Panel Assembly (See Figures 4 & 5)
8	65895	Top Cover Assembly
-	4110621	Screw, Switch Actuator, 10-24 x 5/8"
-	4118001	Hexnut, 10-24
-	4100502	Screw, 10-32 x 1/2" Holt Head (Tamperproof)
-	4107101	Flatwasher, #10
-	65149A	Screwdriver (for 4100502 Screw)

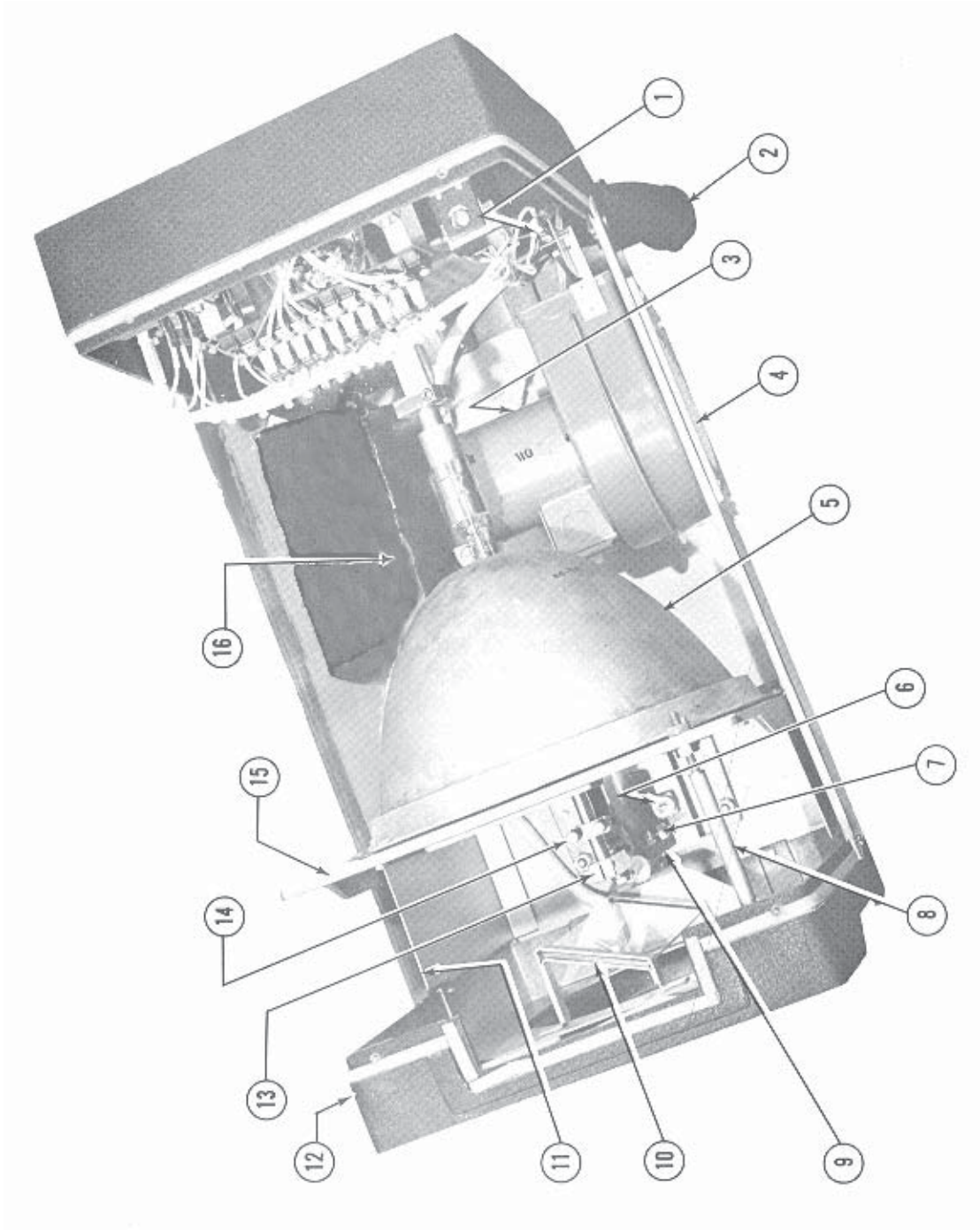

FIGURE 2

## PARTS LIST

Figure 2

<u>Item</u>	<u>Part No.</u>	<u>Description</u>
1	85109	Air Flow Switch (S4)
-	4040750	Screw, 4-40 x 3/4" Round Head
-	4047001	Lockwasher, #4
2	81143	Cable Connector, 90°
-	65935	Lamphouse/Power Supply Interconnect Cable Assembly
-	88318	MS Connector to Power Supply (incl. with 65935)
-	62153	Cable Clamp (for 88318)
3	65932	Blower Assembly (B1) w/ Switch Bracket
-	4080506	Screw, 8-32 x 1/2" Pan Head
-	65158	Switch Bracket
-	01639-2	Pop Rivet
4	83131	Blower Intake Grille
-	4080250	Screw, 8-32 x 1/4" Pan Head
5	23756	Reflector, 10" Diameter, Dichroic Coated
-	4250505	Screw, 1/4-20 x 1/2" Socket Head
-	4057004	Lockwasher, 1/4"
6	65171	Insulator Bushing
-	4081002	Screw, 8-32 x 1" Pan Head
-	4087004	Flatwasher, #8
7	65261	Cathode Lead Connector Stud
-	4258001	Hexnut, 1/4-20
-	4257000	Split Lockwasher, 1/4"
8	65164	Tie Rod (Factory Aligned - <b>Do Not Adjust</b> )
-	4258001	Hexnut, 1/4-20
9	65115	Air Duct Casting
-	65175	Insulator Plate
10	65933	Heat Filter Bracket Assembly
-	4110250	Screw, 10-24 x 1/4" Fillister Head
-	4107001	Lockwasher, #10
-	65122A	Heat Filter, Glass
11	65156	Inner Heat Shield, Right
-	65155	Inner Heat Shield, Left
-	4080310	Screw, 8-32 x 5/16" Pan Head
12	39115	Front Casting
-	41-98034	Plug Button, Chromed; 1/2"



**PARTS LIST, Figure 2 (continued)**

<u>Item</u>	<u>Part No.</u>	<u>Description</u>
13	65148	Contact & Clamp (as shown; 1, 1.6 kW)
-	4080502	Clamping Screw, 8-32 x 1/2" Socket Head
-	65410	Contact & Clamp (2 kW)
-	4080870	Clamping Screw, 8-32 x 7/8" Socket Head
-	4250505	Screw, 1/4-20 x 1/2" Hex Head
-	4257000	Split Lockwasher, 1/4"
-	65948	Negative Lead Wire Assembly (to Shunt)
14	65152A	Thumb Screw (not req'd. for 2 kW)
-	65151	Retainer Plate (not req'd. for 2 kW)
-	65117	Support Yoke Casting (1, 1.6 kW)
-	4110750	Screw, 10-24 x 3/4" Socket Head
14	83747	Cathode Shock Mount Assembly (2 kW only)
-	83748	Ring Assembly
-	83364	Base Mount Bracket
-	4100620	Clamping Screw, 10-32 x 5/8" Socket Head
-	83410	Coil Spring, Shock Mount
15	65114	Reflector Support Casting
-	4250752	Screw, 1/4-20 x 3/4" Hex Head
-	4107000	Split Lockwasher, 1/4"
-	4258001	Hexnut, 1/4-20
16	65503	Igniter Assembly
-	65858	Igniter Case & Coil Assembly
-	25476	Igniter Printed Circuit Board Assembly
-	4100625	Screw, 10-32 x 5/8" Hex Head
-	4108001	Hexnut, 10-32
-	4107101	Flatwasher, #10
-	4107000	Split Lockwasher, #10

NOT SHOWN

65847B	Magnetic Arc Stabilization Kit
39215	Permanent Magnet
41-10004	Clamp

FIGURE 3

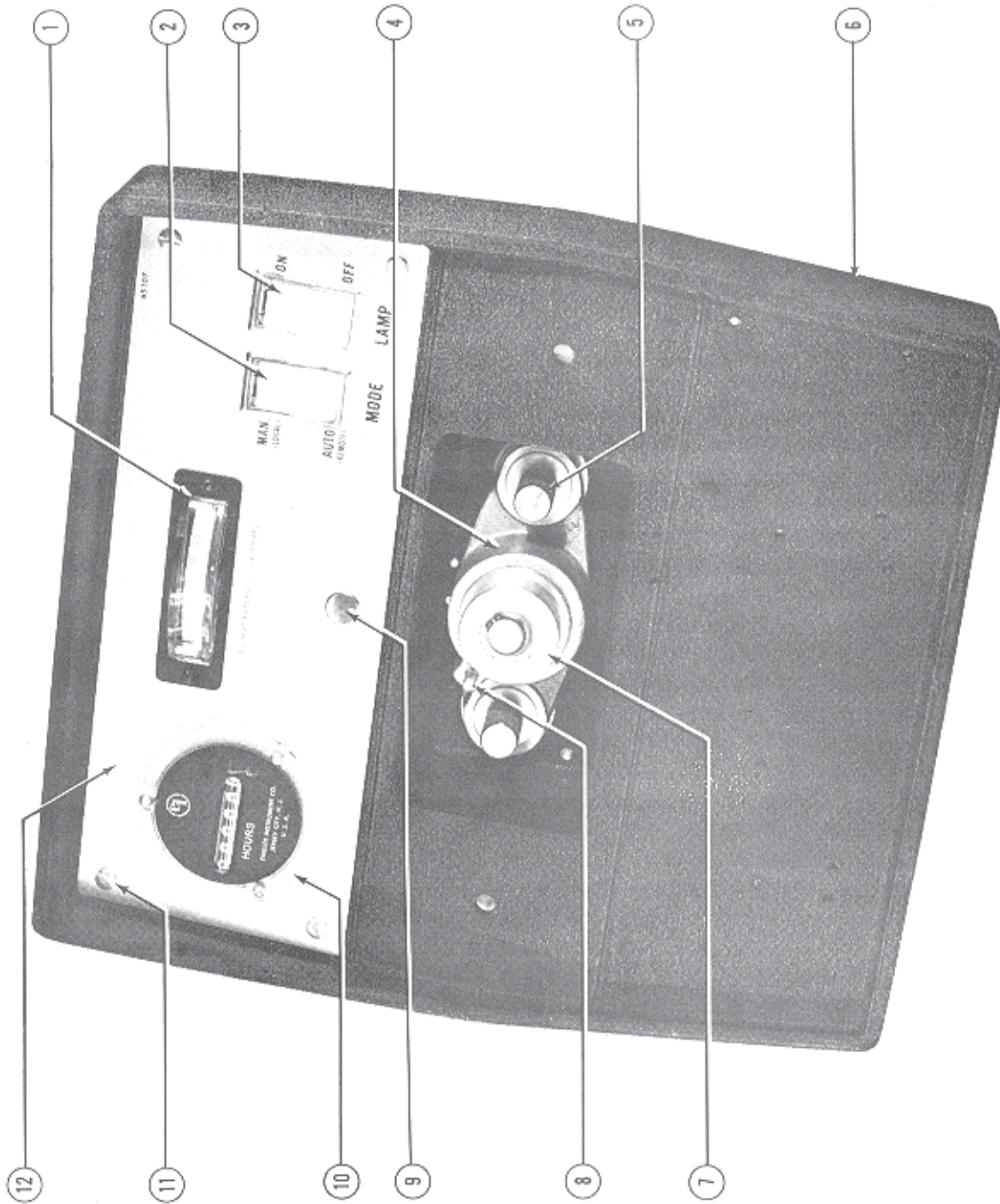

## PARTS LIST

Figure 3

<u>Item</u>	<u>Part No.</u>	<u>Description</u>
1	65142	Ammeter (M2), 0-150 A.
2	81276	MODE Switch (S3), "Auto - Man"
3	81275	LAMP Switch (S2), "On - Off"
4	65116	Casting, Bulb Adjust Control
-	65197	Fender Washer, Inner (not shown)
5	65132	Thumb Screw
-	15010	Compression Spring
-	65150	Fender Washer, Outer
6	65112	Rear Lamphouse Casting
7	65959	Focus Screw & Bearing
8	65153	Focus Lock Screw
-	65154	Nylon Ball, 3/16" Diameter
9	41-98013	Plug Button, Chromed; 3/8"
10	65891	Elapsed Time Meter (M1), 60 Hz.
-	65870	Elapsed Time Meter (M1), 50 Hz.
-	4040500	Screw, 4-40 x 1/2" Round Head
-	4047001	Lockwasher, #4
-	4048003	Hexnut, 4-40 Brass
11	4080181	Screw, 8-32 x 3/16" Bind Head
12	65107	Instrument Panel (less Components)

FIGURE 4

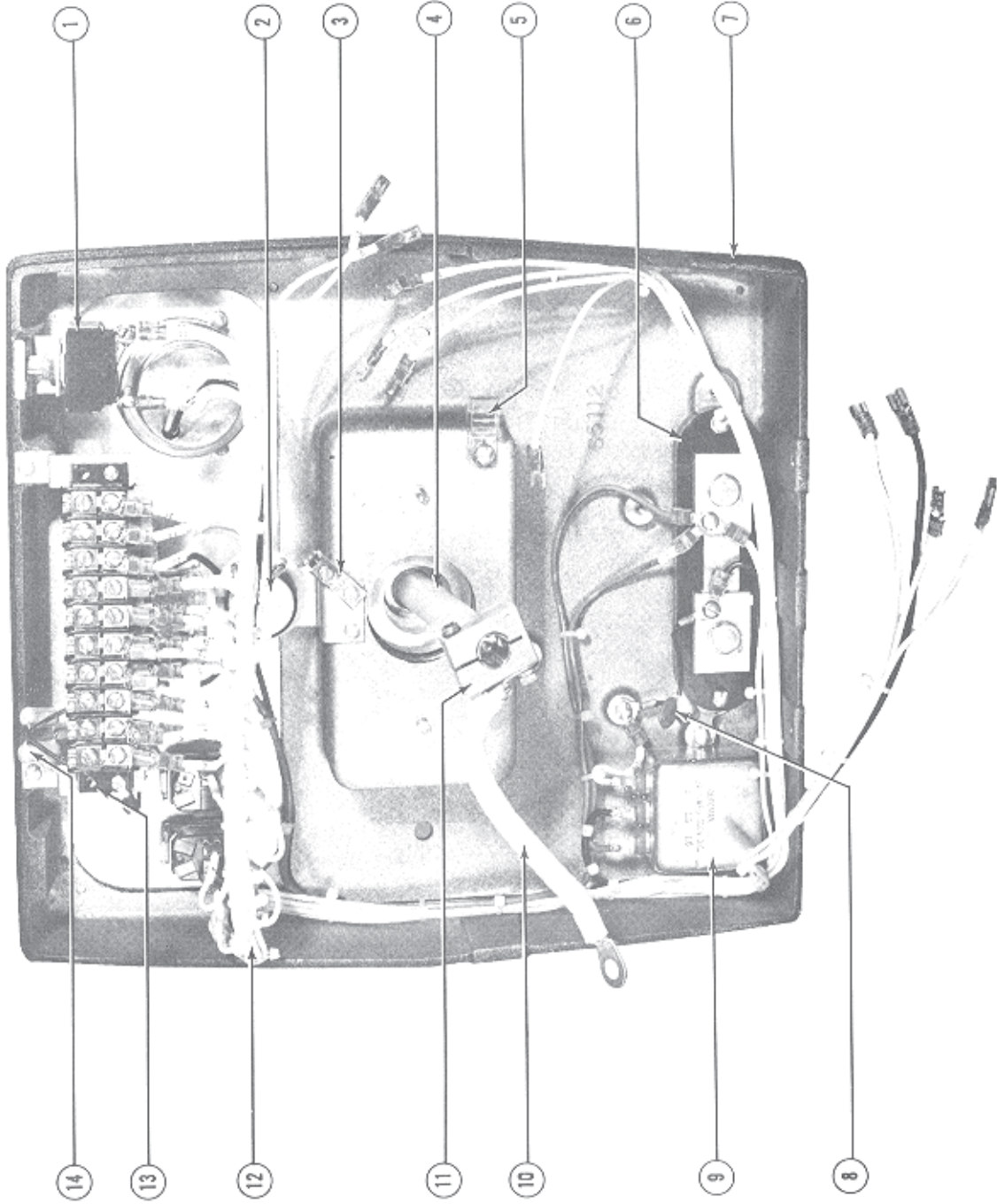

## PARTS LIST

Figure 4

<u>Item</u>	<u>Part No.</u>	<u>Description</u>
1	80168	Cover Interlock Switch (S1)
-	65185	Switch Mounting Bracket
-	4080252	Screw, 8-32 x 1/4" Socket Head
-	4087004	Lockwasher, #8
2	88122	Current Control Potentiometer (early models*)
3	79131	Ground Terminal
4	65960	Anode Support Collet (1, 1.6 kW)
4	65844	Anode Support Collet (2 kW)
5	M4361	Cable Clamp
-	4100504	Screw, 10-24 x 1/4" Fillister Head
-	4107101	Flatwasher, #10
6	82167	Shunt (R1)
-	4101004	Screw, 10-24 x 1" Pan Head
-	4107000	Split Lockwasher, #10
7	65935	Lamphouse/Power Supply Interconnect Cable
-	95119	Bushing, 1-1/4"
-	95120	Lock Nut, 1-1/4"
8	81947	Capacitor (C5)
-	40837A	Grounding Screw, 8-32 x 3/8" Pan Head
9	80177	Capacitor (C4A & C4B)
-	4100371	Screw, 10-32 x 3/8" Pan Head
-	4107001	Lockwasher, #10
10	65966	Positive Cable & Clamp Assembly
-	4250373	Screw, 1/4-20 x 3/8" Hex Head
-	4257000	Split Lockwasher, 1/4"
11	65131	Anode Clamp
-	4080870	Clamping Screw, 8-32 x 7/8" Socket Head
12	65951	Lamphouse Wire Harness Assembly
13	65134	Barrier Strip, (10) Terminal
-	4060500	Screw, 6-32 x 1/2" Pan Head
-	65160	Barrier Strip Mounting Bracket
-	408037A	Screw, 8-32 x 3/8" Pan Head
-	4087004	Lockwasher, #8
14	65890	Capacitor Assembly (C1, C2, C3)
-	4060500	Screw, 6-32 x 1/2" Pan Head

\*

88122 used with Type 88000 Power Supplies only

FIGURE 5

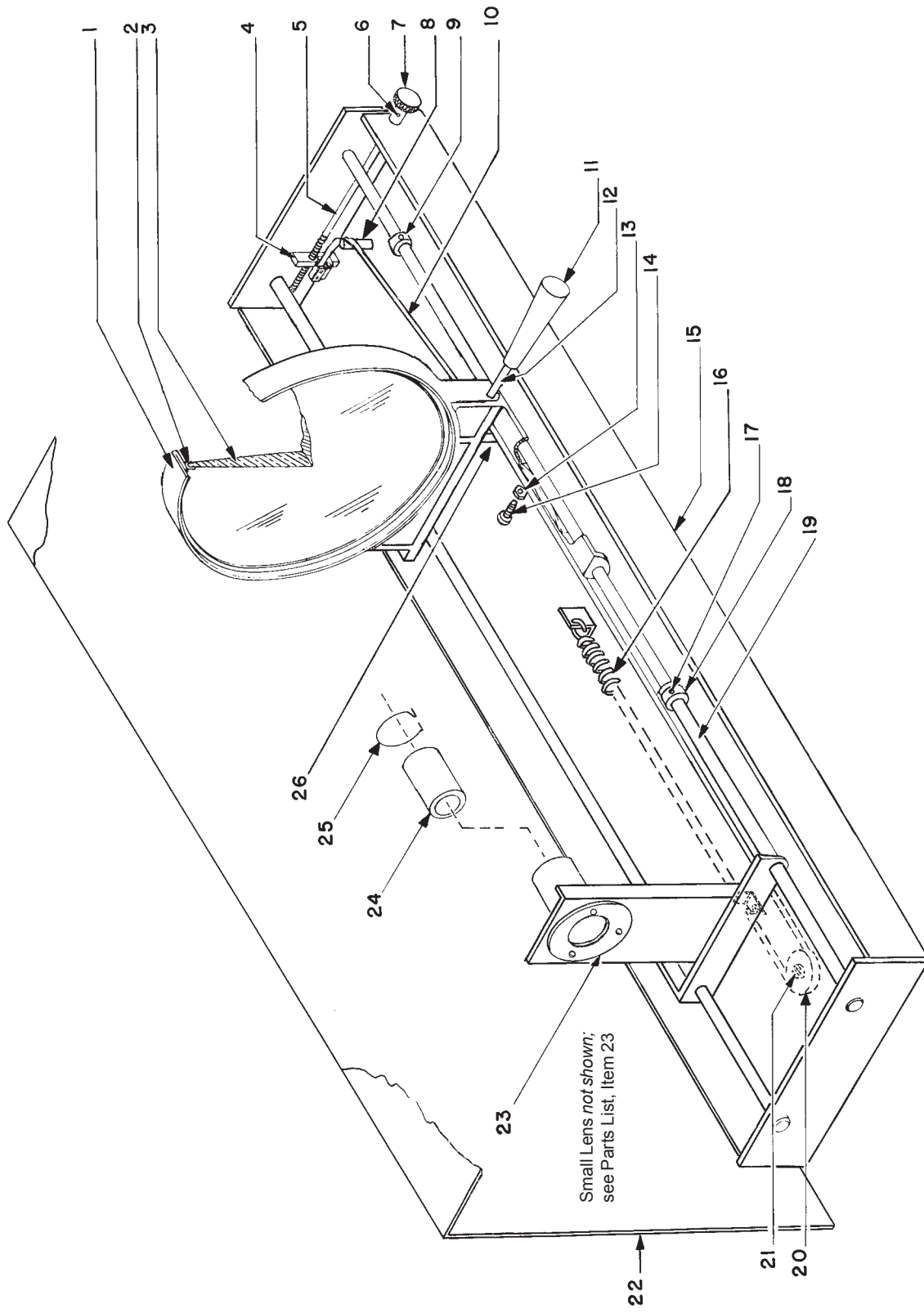

Items 20 & 21 shown offset for clarity. See Figure 7, Items 11-13.

## PARTS LIST

Figure 5

<u>Item</u>	<u>Part No.</u>	<u>Description</u>
1	51875	Carriage Casting, Large Lens
2	51493	Lens Retaining Ring
-	51492	Rubber Lens Cushion
-	4080310	Screw, 8-32 x 5/16" Pan Head
-	4087100	Flatwasher, #8 Brass
-	4107101	Flatwasher, #10
3	51102	Large Lens
4	51133	Lens Focus Block
5	51489	Lens Focus Shaft
-	4107101	Flatwasher, #10
-	01475	Cotter Pin, 1/16" x 3/8"
6	4080120	Set Screw, Focus Knob; 8-32 x 1/8"
7	51168	Focus Knob, Lens Mechanism
8	51167	Post, Focus Ribbon
-	4250506	Mounting Screw, 1/4-20 x 1/2" Flat Head
9	51114	Stop Collar
10	51992	Lens Focus Ribbon
11	51509	Handle, Red Plastic
12	48401	Handle Shaft
13	4258015	Lock Nut, 1/4-20 Nylon Hex
14	4251001	Friction Brake Screw, 1/4-20 x 1" Hex Head Nylon
15	48899	Base Pan, Welded Assembly
16	51162	Tension Spring
17	4100252	Set Screw, 10-32 x 1/4"
18	51114	Stop Collar
19	51485	Slide Rod (Left & Right)
-	48127	Truarc Ring, #5100-56
-	48147	Truarc Ring, #5101-56
20	51157	Pulley, Focus Ribbon
21	51160	Pulley Stud
-	4087100	Flatwasher, #8 Brass
22	48895	Lens Housing Welded Assembly
-	4100371	Screw, 10-32 x 3/8" Pan Head
-	4250508	Screw, 1/4-20 x 1/2" Pan Head
23	48896	Small Lens Carriage Welded Assembly
-	51101	Small Lens (not shown; mounts to 48896)
-	48404	Small Lens Mounting Plate (not shown; 2 req'd.)
-	48403	Mounting Tube (for Item 24 Lens)
-	4080753	Tube Mounting Screw, 8-32 x 3/4" Flat Head

FIGURE 6

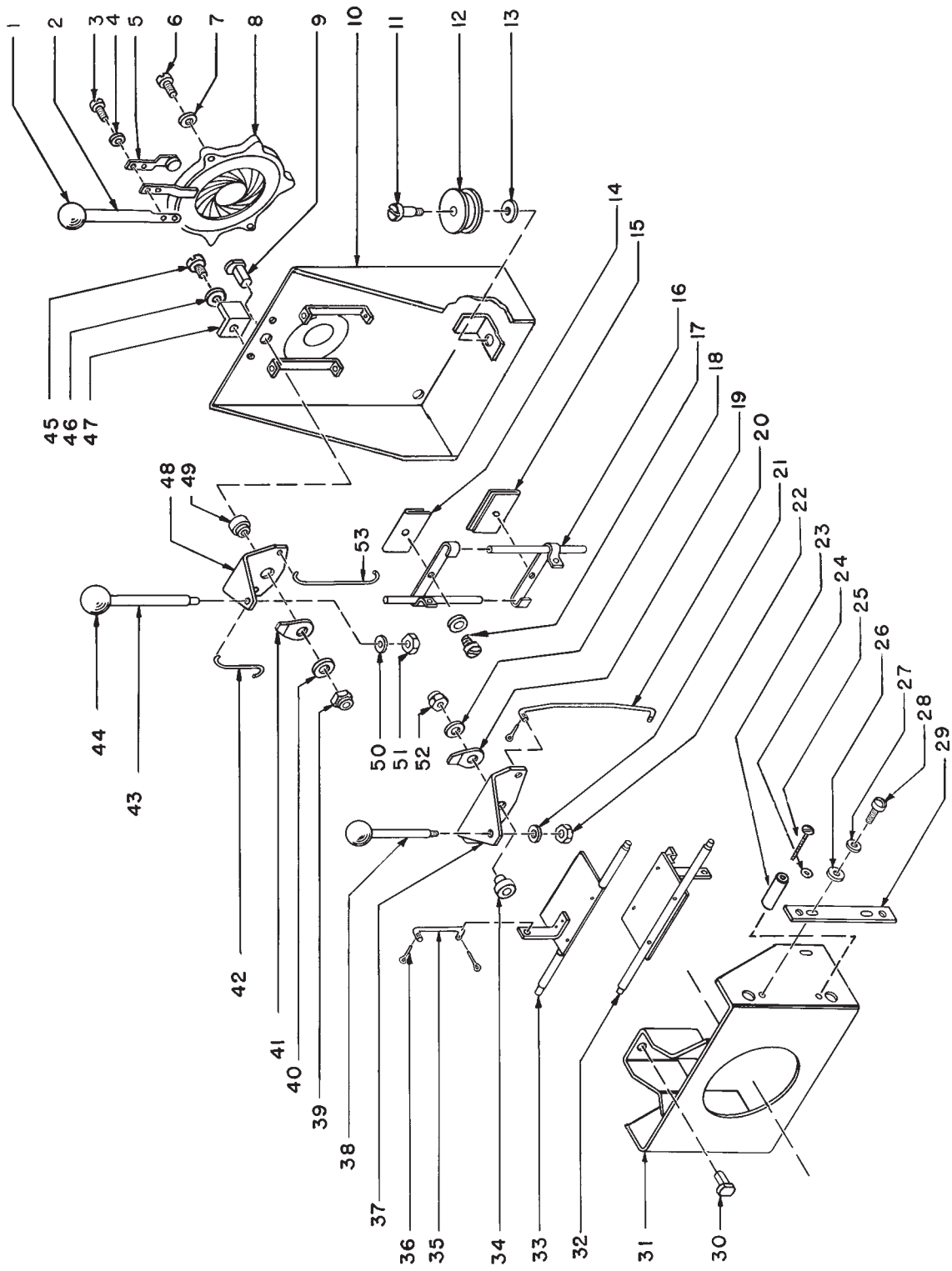



## PARTS LIST

Figure 6

<u>Item</u>	<u>Part No.</u>	<u>Description</u>
1	10048A	Knob, Red Plastic
2	48402	Iris Shaft
3	406037B	Screw, 6-32 x 3/8" Pan Head
4	4067001	Lockwasher, #6
5	51978	Friction Spring & Pad (for 51979)
6	4060620	Screw, 6-32 x 5/8" Pan Head
7	4067001	Lockwasher, #6
8	51979	Iris (as shown; also see Figure 6A)
		<i>See Figure 6A for current configuration</i>
9	51226	Stud, Chopper Blade
10	25244	Aperture Support Plate
-	25235	Mounting Block, Aperture Plate (see Fig. 6A)
11	51160	Pulley Stud
12	51157	Small Pulley
13	4087100	Flatwasher, #8 Brass
14	47191	Chopper Blade
15	47191	Chopper Blade
16	47982	Slide Assembly, Chopper Blade
17	4080181	Screw, 8-32 x 3/16" Pan Head
-	4087004	Lockwasher, #8
18	4257102	Washer, 1/4" Steel, S.A.E.
19	51156	Friction Plate (Replace with 4507106 Friction Washer)
20	51602	Pull Rod, Lower Fadeout Blade
21	4257000	Split Lockwasher, 1/4"
22	4258001	Hexnut, 1/4-20
23	51517	Spacer
24	4107101	Flatwasher, #10
25	4101500	Screw, 10-32 x 1-1/2" Pan Head
26	4107101	Flatwasher, #10; .036" Thick
27	4107001	Lockwasher, #10
28	4080250	Screw, 10-32 x 1/4" Pan Head
29	51443	Pivot Shaft Retainer
30	51226	Stud, Chopper Blade
31	48898	Fadeout Mechanism Bracket, Welded Assembly
32	48878	Lower Fadeout Blade
33	48879	Upper Fadeout Blade
34	51153	Pivot Bushing
35	51515	Pull Rod, Upper Fadeout Blade
36	00919	Cotter Pin, 1/16" x 1/2"
37	51520	Fadeout Control Handle Bracket
38	51452	Handle, Fadeout Control

**PARTS LIST, Figure 6 (continued)**

<u>Item</u>	<u>Part No.</u>	<u>Description</u>
39	4318004	Nut, 5-16-18 FlexLock Hex
40	4257102	Washer, 1/4" Steel, S.A.E.
41	51156	Friction Plate (Replace with 4507106 Friction Washer)
42	51498	Chopper Pull Rod, Short
43	51155	Handle, Chopper Control
44	10048A	Knob, Red Plastic
45	4080250	Screw, 8-32 x 1/4" Pan Head
46	4087004	Lockwasher, #8
47	47170	Iris Stop Bracket
48	48406	Bracket, Chopper Control Handle
49	51153	Pivot Bushing
50	4257000	Split Lockwasher, 1/4"
51	4258001	Hexnut, 1/4-20
52	4318004	Locknut, 5/16-18
53	51497	Chopper Pull Rod, Long

Part No.	Description
21-37011	Roll Pin, 3/32 x 9/16"
21-70029	Spring Washer
24369	Bell Crank
24372	Adapter Ring
24374	Iris
25017	Bushing (with 41-51530)
25034	Iris Clamp
25235	Base, Aperture Plate
25244	Aperture Plate
406037B	Screw, 6-32 x 3/8"
4080621	Screw, 8-32 x 5/8"
4100500	Screw, 10-32 x 1/2"
41-51530	Shoulder Bolt
48402	Iris Control Handle
72-00075	Link
81432	Shoulder Screw

FIGURE 6A

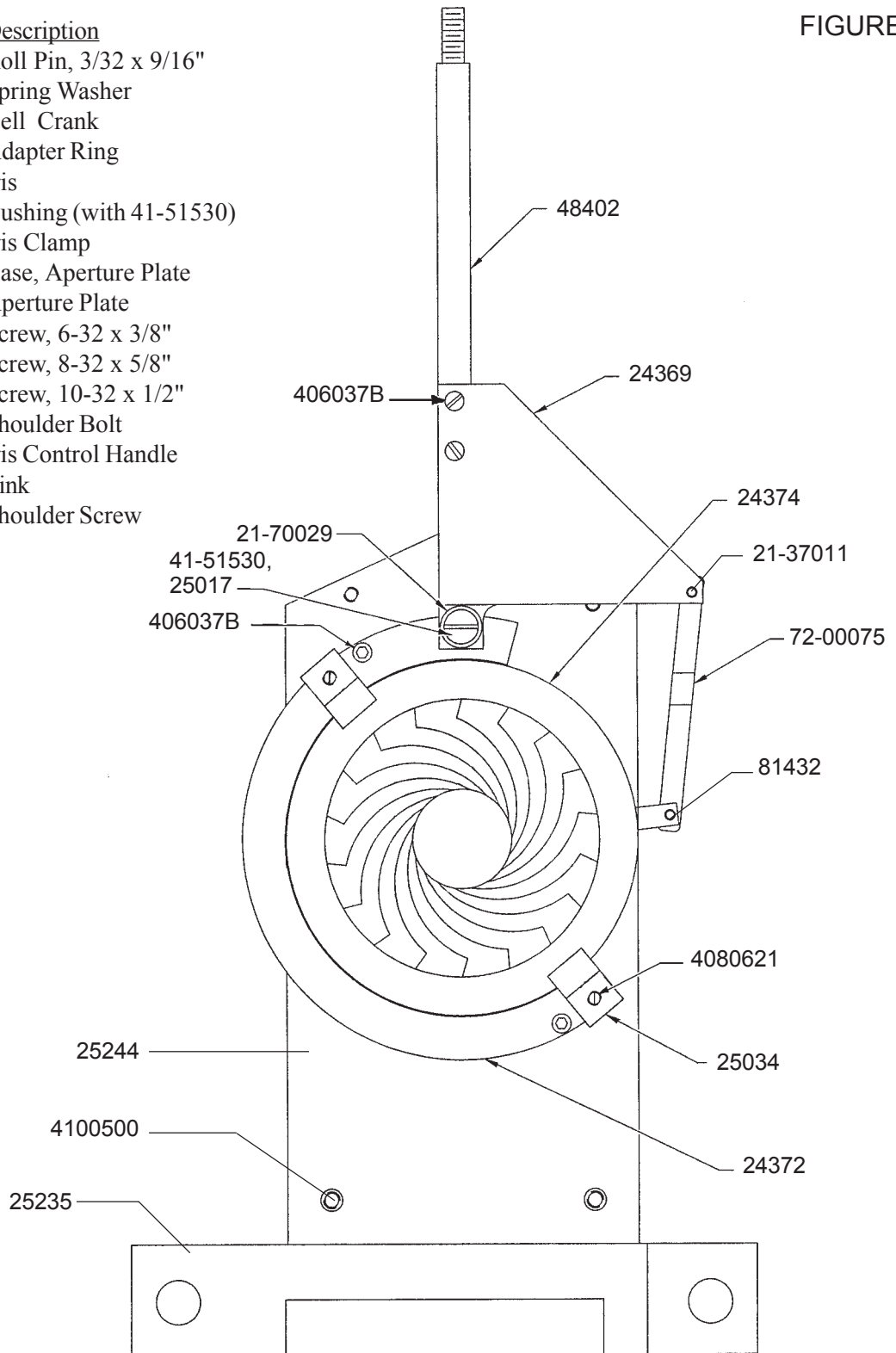

# 51850 BOOMERANG ASSEMBLY

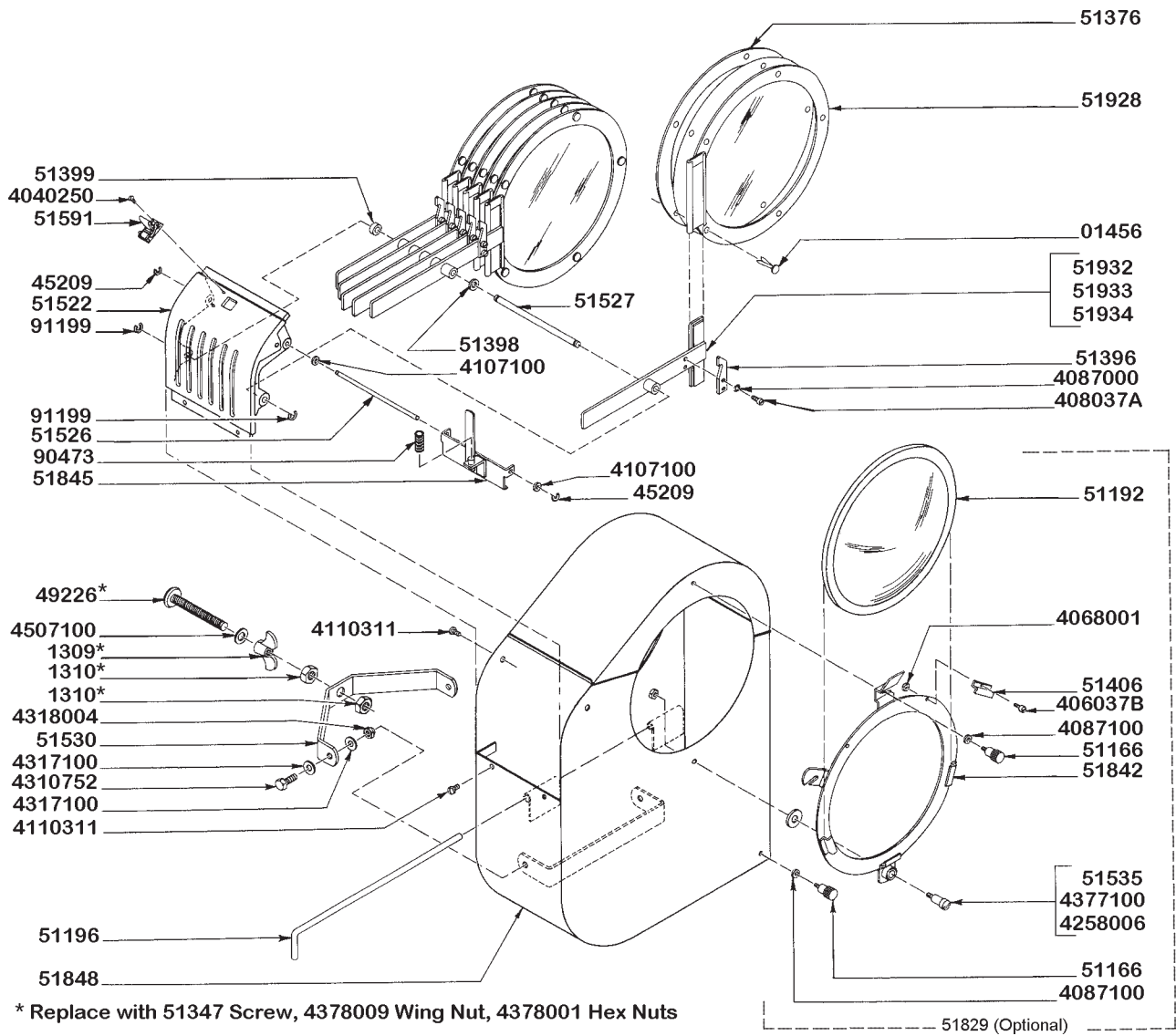

## BOOMERANG PARTS LIST

<u>Part No.</u>	<u>Description</u>
01456	Paper Fastener
51850	Boomerang Assembly
45209	"E" Ring, 3/16"
49226*	Adjusting Screw (as shown; Replace with 51347*)
51166	Shoulder Screw
51192	Ultra Violet Filter
51196	Hinge Pin
51347*	Adjusting Screw (Mfr. 1991 and Later)
51376	Cover Plate, Color Frame
51396	Catch
51398	Nylon Spacer Washer
51399	Spacer
51406	Clip, U.V. Filter
51522	Frame, Color Disc Housing
51526	Shaft, Rocker Catch Pivot
51527	Shaft, Color Disc Pivot
51530	Yoke
51535	Screw, U.V. Filter Pivot
51591	Latch, Color Disc Housing
51842	U.V. Filter Support Frame Assembly
51845	Rocker Catch Assembly
51848	Housing, Welded Assembly
51928	Color Frame Slide Channel Assembly
51932	Arm Assembly (5-3/16")
51933	Arm Assembly (4-11/16")
51934	Arm Assembly (4-3/16")
90473	Spring
91199	"E" Ring, 5/16"
4040250	Screw, 4-40 x 1/4" Pan Head
406037B	Screw, 6-32 x 3/8" Pan Head
4068001	Nut, 6-32, Steel
408037A	Screw, 8-32 x 3/8" Pan Head
4087000	Lockwasher, #8 Split Ring
4087100	Washer, #8 Brass, 3/8" O.D.
4107100	Washer, #10 Brass, 7/16" O.D.
4110311	Screw, 10-24 x 5/16" Pan Head
4258006	Jam Nut, 1/4-20
4310752	Screw, 5/16-18 x 3/4" Hex Head
4317100	Washer, 5/16"
4318004	Locknut, 5/16-18 x 1/4"
4377100	Washer, 3/8" Brass, 7/8" O.D.
4507100	Washer, 1/2" S.A.E.

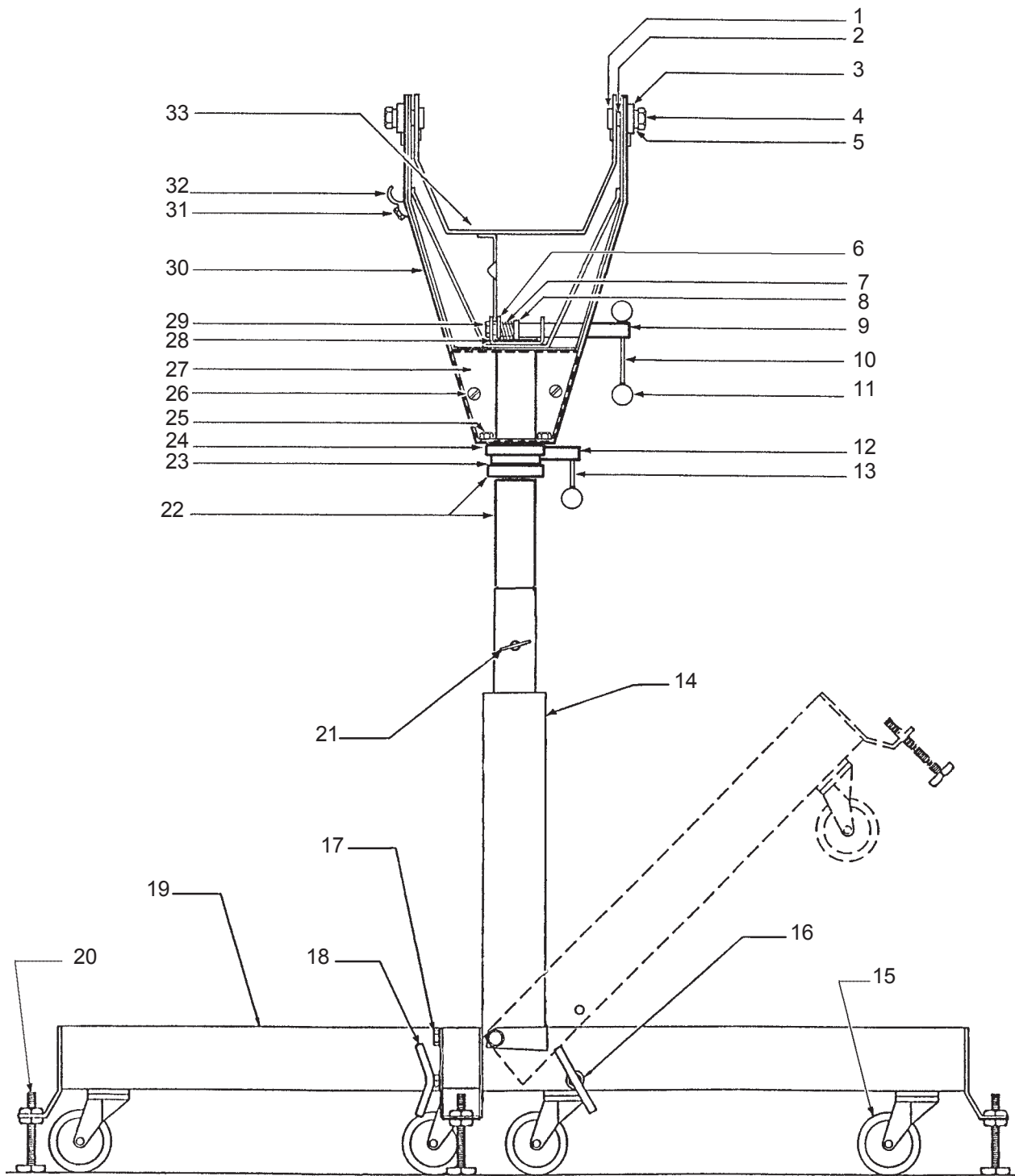

**FOLDING BASE & STAND**  
 Assembly No. 65838

**PARTS LIST**  
Folding Base & Stand

<u>Item</u>	<u>Part No.</u>	<u>Description</u>
1	49120	Tilt Axis Bolt
2	02411	Washer, 1.25" O.D. x .640" I.D.
3	49121	Washer, Tilt Axis
4	4378001	Hexnut, 3/8-16
5	4377103	Flatwasher, 3/8" S.A.E.
6	49126	Clamping Plate
7	49125	Clamping Spring, Compression
8	49124	Clamp Bushing
9	49129	Shaft, Tilt Clamp
10	49130	Handle, Clamp Shaft
11	10048A	Knob, Red Plastic
12	49179	Swivel Clamping Shaft
13	49114	Handle Stud, Swivel Clamp
-	10048A	Knob, Red Plastic
14	83742	Base Column, Welded Assembly
15	49208	Swivel Caster
16	4377103	Flatwasher, 3/8" S.A.E.
17	4433000	Screw, 7/16-14 x 3" Hex Head
-	4437100	Flatwasher, 7/16"
-	4438002	Nut, 7/16-14 FlexLock
18	83745	Leg T-Bolt, Welded Assembly
19	83744	Base Leg, Welded Assembly
20	49226	Leveling Foot
-	4508001	Lock Nut, 1/2-13 Hex
21	48395	Height Adjust Pin, 3/8" Diameter
22	65824	Inner Tube & Ring Welded Assembly
23	48399	Bronze Washer
24	83381	Collar, Swivel Clamp
25	4250503	Screw, 1/4-20 x 1/2" Hex Head
26	4080310	Screw, 8-32 x 5/16" Pan Head
27	48394	Yoke Cover Plate
28	65431	Inner Tube Retaining Collar
29	4502500	Screw, 1/2-13 x 2-1/2" Hex Head
30	65823	Yoke, Welded Assembly
31	4250623	Screw, 1/4-20 x 5/8" Hex Head
32	83341	Cable Clamp
33	48884	Saddle & Quadrant Plate, Welded Assembly

**ASSEMBLIES**

65838	Base & Stand, Complete (Items 1-33)
18765	Folding Base Assembly (Items 14-20)







